

Operating instructions

Electric Hydraulic Power Pack
XE1power, XE1hpr, XE1 50/60Hz

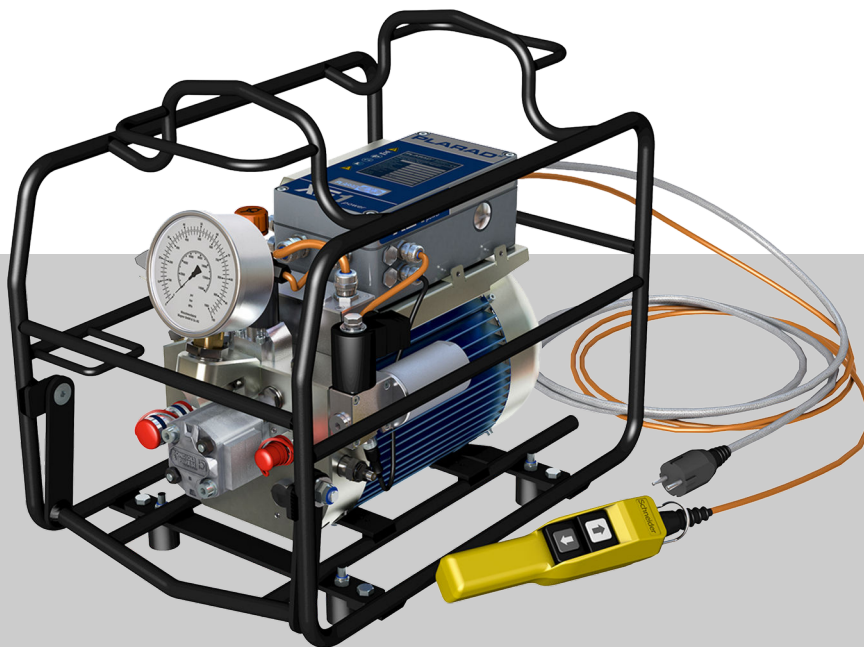

PowerPaX

PLARAD® 
Torque & Tension Systems

Read the manual carefully before use!
Keep for future use.

Maschinenfabrik Wagner GmbH & Co. KG

Birrenbachshöhe 17

53804 Much

GERMANY

Telephone: +49 2245 62-0

Fax: +49 2245 62-22

Email: info@plarad.de

Internet: www.plarad.de

Translation of the original operating instructions

pA# 82028, 2, en_GB



Information about this manual



This manual enables safe and efficient handling of the electric hydraulic power packs PLARAD PowerPaX (referred to in the following as “hydraulic power pack”).

The manual is a component of the hydraulic power pack and must be kept in its immediate vicinity where the user can access it at any time.

The user must have read and understood this manual prior to commencing any tasks. A basic prerequisite for ensuring that work is performed safely is compliance with all safety instructions and guidelines in this manual. In addition, the local accident prevention regulations and general safety provisions for the hydraulic power pack’s area of application apply.

Illustrations in this manual serve to provide a basic understanding and may differ from the actual design.

PLARAD[®] PowerPaX

The PLARAD[®] PowerPaX electric hydraulic power packs are available in different versions and configurations.

Overview of the options ↪ *Chapter 2.4 ‘PowerPaX versions’ on page 13.*

Other applicable documents

The following documents must be observed in addition to this manual:

- Rating plate
 - EU declaration of conformity
 - Test report for testing electrical equipment as per DIN VDE 0701-0702
Testing of equipment as per DGUV Regulation 3
 - Certificates/test reports (option)
 - Technical data sheet (dimension sheet)
- ↪ www.plarad.de

Copyright

This manual is protected by copyright.

The transfer of this manual to third parties, duplications of any kind and form – including excerpts – as well as the utilisation and/or communication of the manual’s contents are not permitted without the written consent of Maschinenfabrik Wagner GmbH & Co. KG, except for internal purposes. Infringements will result in liability for damages. Maschinenfabrik Wagner GmbH & Co. KG reserves the right to assert additional claims.

Maschinenfabrik Wagner GmbH & Co. KG is the copyright holder.

Further development of the manual

This manual was compiled with great care. If you notice any errors, have any questions or identify any inconsistencies, please notify us in writing. Your suggestions for improvement will help us design a user-friendly manual.

Follow-up order

Further copies of this manual can be ordered subject to an additional fee.

Contact ↗ *'Manufacturer'* on page 4.

Manufacturer

Maschinenfabrik Wagner GmbH & Co. KG

Birrenbachshöhe 17

53804 Much

GERMANY

Telephone: +49 2245 62-0

Telefax: +49 2245 62-22

Email: info@plarad.de

Internet: www.plarad.de

PLARAD[®] service

Information about PLARAD[®] service and authorised PLARAD[®] partners:

- www.plarad.de



Table of contents

1	Unpacking and transporting	7
2	Getting to know the hydraulic power pack	11
2.1	Overview of the hydraulic power pack.....	11
2.2	Brief description.....	12
2.3	Rating plate.....	13
2.4	PowerPaX versions.....	13
2.5	Display elements and controls.....	14
2.6	Operating modes.....	15
2.7	Remote control.....	16
2.7.1	Buttons of the remote control.....	16
2.8	Functions.....	17
2.9	Connections.....	17
2.10	Accessories.....	18
3	Before you begin – safety	19
3.1	Symbols in this manual.....	19
3.2	Symbols on the hydraulic power pack.....	21
3.3	Intended use.....	23
3.4	Misuse.....	24
3.5	Residual risks.....	24
3.5.1	Electrical dangers.....	25
3.5.2	Danger due to hydraulics.....	27
3.5.3	Mechanical dangers.....	29
3.5.4	Noise and ergonomics.....	30
3.6	Operator's obligations.....	33
3.7	Who may use the hydraulic power pack?.....	34
3.8	Personal protective equipment.....	35
3.9	Environmental protection.....	37
4	Choosing the installation site	38
5	Supplying with energy	40
6	Preparing for operation	43
6.1	Prior to switching on.....	43
6.2	Starting the hydraulic power pack.....	44
6.3	Using the hydraulic power pack at low temperatures.....	45
6.4	Connecting the hose.....	46
6.5	Setting the operating pressure.....	47
6.6	Flushing.....	48
7	Working with hydraulic wrenches	49
7.1	Manual operation – tightening.....	50
7.2	Manual operation – loosening.....	51
8	Performing maintenance	52
8.1	Maintenance schedule.....	52

8.2	Having the hydraulic power pack maintained by the user.....	54
8.3	Changing the oil.....	55
8.4	Having service tasks performed by the manufacturer.....	56
9	Troubleshooting.....	57
9.1	Error messages in the XB32 display.....	57
9.2	Performing troubleshooting.....	58
10	Disposal.....	60
11	Technical data.....	61
12	Index.....	63
	Appendix.....	66



1 Unpacking and transporting

Delivery



Fig. 1: Example, shipping crate

The hydraulic power pack is delivered together with the rest of the scope of delivery in packaging adapted to the transport route and delivery location.

For example, this could be a wooden crate delivered on a pallet. The hydraulic power pack is wrapped in film to ensure that no hydraulic oil can escape.

Checking the delivery



Check the delivery for transport damage and ensure it is complete immediately upon receipt. If it is incomplete or if there are defects, note the extent of the damage on the transport documents and lodge a complaint immediately.

Scope of delivery

The scope of delivery includes:

- Hydraulic power pack filled with hydraulic oil
- Document folder
 - Operating instructions
 - EU declaration of conformity

Options:

- Any accessory ordered
- Test reports

Handling packaging material

The individual packages are packed according to the expected transport conditions. Only environmentally friendly materials are used for the packaging.

The packaging should provide protection against transport damage, corrosion and other damage. For this reason, do not destroy the packaging and do not remove it until shortly before use.

Dispose of packaging material in accordance with the applicable statutory provisions and local regulations.



ENVIRONMENT!

Danger to the environment due to incorrect disposal!

Packaging materials are valuable raw materials and, in many cases, can be further utilised or appropriately reconditioned and recycled. Incorrect disposal of packaging materials can be hazardous to the environment.

- Reuse pallets.
- Dispose of packaging materials in an environmentally sound manner.
- Observe the locally applicable disposal regulations. If necessary, engage the services of a specialist company with regard to disposal.

Transport by a forwarding agent

Observe the following points when the hydraulic power pack is transported in a vehicle by a forwarding agent or parcel service:

1. ➤



WARNING!

Danger of crushing from unsecured load!

Ensure that the load is properly secured in the vehicle. Secure the hydraulic power pack in such a way that it cannot slide out of position during transport.

2. ➤



ENVIRONMENT!

Danger to the environment due to hydraulic oil leakage!

Ensure that the hydraulic power pack is horizontal and protected from shocks and impacts for the entire duration of transport.

Never put the hydraulic power pack on its side or position it upside down.

3. ➤

Put the hydraulic power pack in a foil bag to prevent oil spillage in the event of an accident.



Transport with an industrial truck

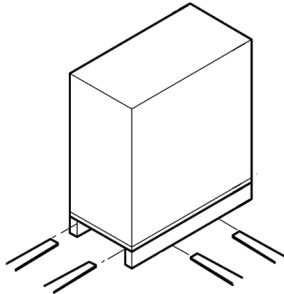

Fig. 2: Transport with an industrial truck

1. ➤ Ensure that the industrial truck is designed for the weight of the transport item. For details of the weight, see [Chapter 2.3 'Rating plate' on page 13](#).
2. ➤ Drive the forks of the industrial truck between or under the bars of the pallet.
3. ➤ Drive in the forks until they protrude on the opposing side.

4. ➤



WARNING!

Danger of crushing due to the package tipping over!

If the centre of gravity is eccentric, ensure that the pallet cannot tip over.

5. ➤ Lift the pallet with the transport item and commence transport.

Transport by crane

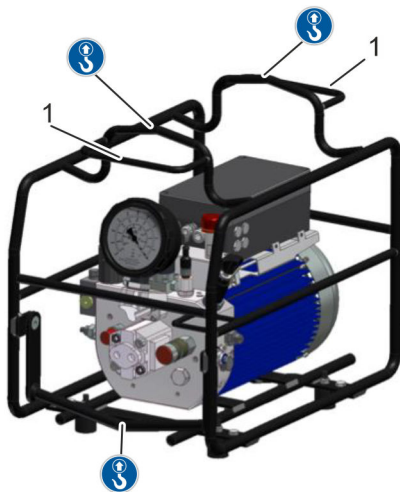

Fig. 3: Transport

Protective equipment: ■ Industrial safety helmet

If unpacked, the hydraulic power pack can be transported by crane.

The attachment points are marked with **S**.

The cables can be rolled up on the holders (Fig. 3/1).

1. ➤ Ensure that the crane and hoists are designed for the weight of the hydraulic power pack. For details of the weight, see [Chapter 2.3 'Rating plate' on page 13](#).
2. ➤ Attach the ropes, slings or multi-point suspension gear in the proper manner.

3. ➤



WARNING!

Danger of crushing due to the hydraulic power pack falling!

Ensure that the hydraulic power pack hangs straight. Observe the eccentric centre of gravity as necessary.

4. ➤ Commence transport.

Do not loiter under suspended loads.

Transport by hand

1. ➤ Remove any hoses that are connected.

2. ➤



WARNING!
Danger of tripping!

Neatly roll up the power cable and the remote control cable and secure them on the frame of the hydraulic power pack. For information about holders for rolling up the cables, see Fig. 3/1.

3. ➤ Seal the couplings and nipples with the caps prior to transport.

4. ➤ Ensure that all openings (e.g. cover of the surge tank) are sealed.

5. ➤



WARNING!
Danger of injury due to high weight!

Carry with the aid of a second person. In doing so, keep the transport item horizontal at all times. Never turn it upside down.

Transport after operation



WARNING!
Danger of burns due to hot surfaces or hydraulic oil!

In the event of a high ambient temperature and prolonged operation, the hydraulic power pack can reach surface temperatures of up to 80 °C. The hydraulic oil gets hot when pressurised. Contact with hot surfaces and hot hydraulic oil could result in severe burns.

- Let the hydraulic power pack cool down prior to transport.
- Seal all openings.
- Wear personal protective equipment.

Storage

- Ensure disconnection from the power supply grid during storage.
- Put it in a horizontal position.
- Comply with ambient conditions ↪ *Chapter 11 'Technical data' on page 61.*
- Seal all openings (couplings, nipples, surge tank).
- Roll up the power cable and the remote control cable. Do not twist, kink or subject to any other mechanical loads.

2 Getting to know the hydraulic power pack

2.1 Overview of the hydraulic power pack

XE1 50/60Hz

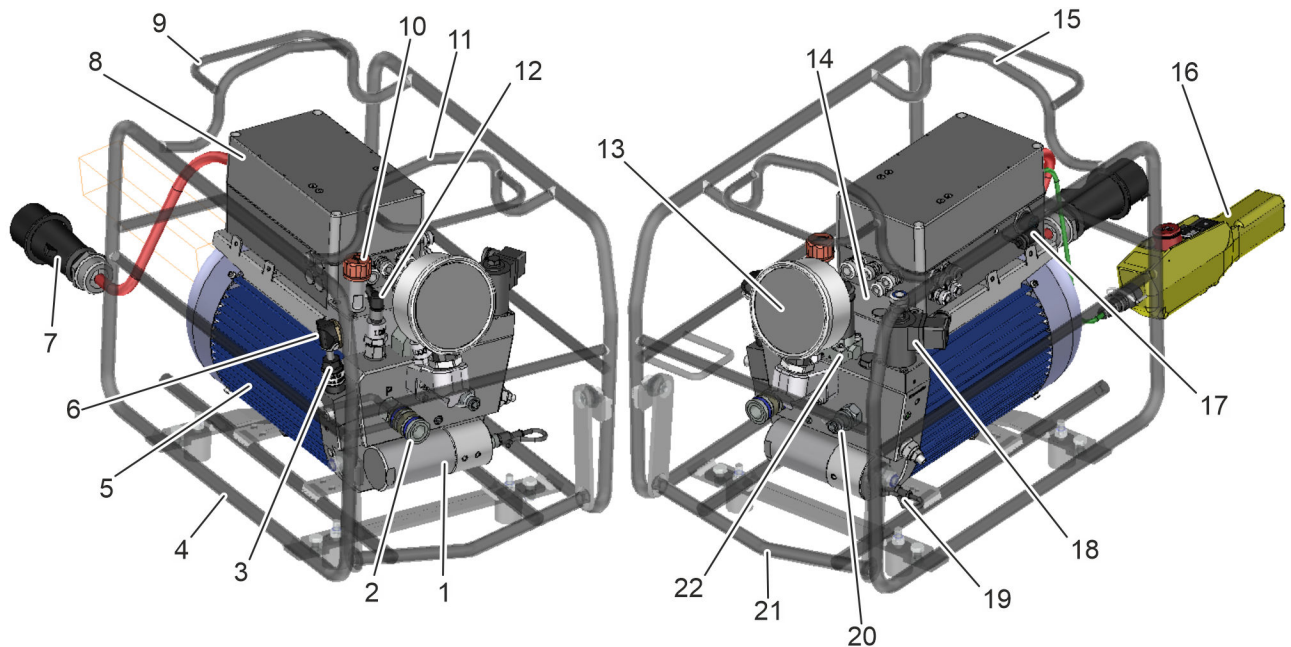

Fig. 4: XE1 50/60Hz-3.5

- | | | | |
|----|--|----|---|
| 1 | Oil filter | 13 | Pressure display |
| 2 | Hydraulic connection, pressure-side | 14 | Sticker for oil level |
| 3 | Pressure adjustment valve with adjustment lock | 15 | Attachment point for transport by crane |
| 4 | Supporting frame | 16 | Remote control |
| 5 | Drive (oil-immersed motor) | 17 | Documentation and service interface |
| 6 | Sight glass for oil level | 18 | Pressure relief valve |
| 7 | Power cable | 19 | Pressure sensor |
| 8 | Control system | 20 | Hydraulic connection, return-side |
| 9 | Holder for cable collection | 21 | Attachment point for transport by crane |
| 10 | Oil filling neck | 22 | Main valve |
| 11 | Attachment point for transport by crane | - | Oil drain plug (under the motor) |
| 12 | Low-pressure adjustment valve for the return stroke Set at the factory (approx. 130 bar). Do not change the setting! | | |

PLARAD[®] hydraulic power packs can be designed for mains frequencies of 50 Hz or 60 Hz. XE1 50/60Hz can be operated with mains frequencies of between 50 Hz and 60 Hz.

Just like the XE1power hydraulic power pack, the XE1 50/60Hz provides the basic functions for operating hydraulic wrenches up to 800 bar.

XE1power

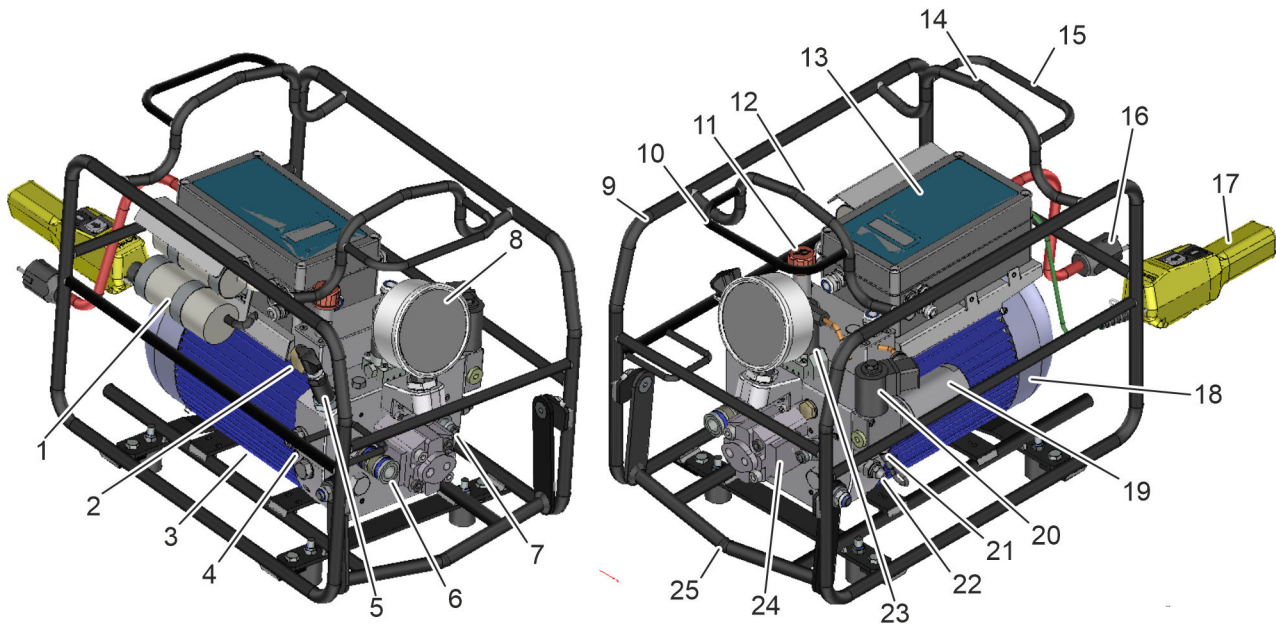

Fig. 5: XE1power

- | | | | |
|----|--|----|--|
| 1 | Starting capacitors | 14 | Attachment point for transport by crane |
| 2 | Sight glass for oil level | 15 | Holder for cable collection |
| 3 | Oil drain plug (under the motor) | 16 | Power cable |
| 4 | Adjustment valve, gear pump switching point.
Set at the factory. Do not change the setting! | 17 | Remote control |
| 5 | Pressure adjustment valve with adjustment lock | 18 | Drive (oil-immersed motor) |
| 6 | Hydraulic connection, pressure-side | 19 | Oil filter |
| 7 | Hydraulic connection, return-side | 20 | Pressure relief valve |
| 8 | Pressure display | 21 | Temperature sensor in the oil filter |
| 9 | Supporting frame | 22 | Low-pressure adjustment valve for the return stroke Set at the factory (approx. 130 bar). Do not change the setting! |
| 10 | Holder for cable collection | 23 | Main valve |
| 11 | Oil filling neck | 24 | Gear pump (2-stage version only) |
| 12 | Attachment point for transport by crane | 25 | Attachment point for transport by crane |
| 13 | Control system | | |

XE1hpr

Special features of the hydraulic power pack XE1hpr:

In contrast to the XE1power hydraulic power pack, the maximum pressure of the XE1hpr hydraulic power pack is limited to 350 bar.

2.2 Brief description

The hydraulic power pack is a transportable, hydraulic pressure generator for operating PLARAD[®] hydraulic wrenches to produce manual bolted connections.

The hydraulic power pack may only be used for commercial purposes.

The hydraulic power pack is electrically powered.



The hydraulic power pack may be operated on a fixed operating network or mobile power generators, subject to compliance with the connected loads stated under ↪ *Chapter 11 'Technical data' on page 61.*

2.3 Rating plate

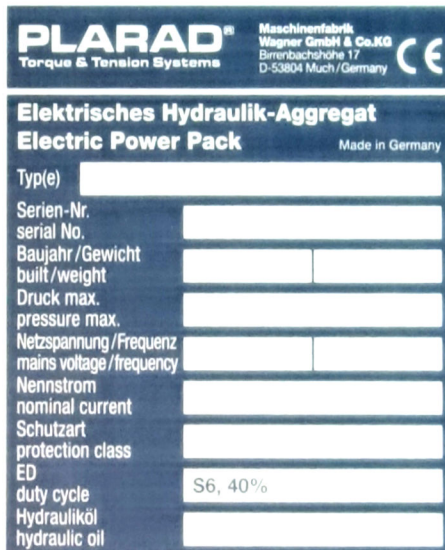

Fig. 6: Rating plate

The following data is inscribed on the rating plate:

- Name of the manufacturer including their full address
- CE mark
- Machine designation
- Type designation
- Serial number
- Year of construction
- Weight
- Maximum pressure
- Mains voltage/frequency
- Nominal current
- Protection class
- Duty cycle
- Hydraulic oil

2.4 PowerPaX versions

PLARAD[®] hydraulic power packs are available in different versions.

Motor sizes

Available motor versions:

- 1 | 10
- 2 | 20
- 3,5 | 35

Mains voltage/frequency

Available mains voltages and mains frequencies:

- 230 V/50 Hz
- 230 V/60 Hz
- 110 V/50 Hz
- 110 V/60 Hz
- 3-400 V/50 Hz
- 3-400 V/60 Hz
- 3-480 V/50 Hz
- 3-480 V/60 Hz
- Others on request

Process connections  *'Process connections' on page 17*

Power plug  *'Power plug' on page 17*

Cable length – power cable

- 5 m
- 10 m
- Others on request

Cable length – remote control

- 5 m
- 10 m
- Others on request

Auxiliary tank

- Surge tank (standard)
- 4-litre auxiliary tank (option)

Pressure display  *'Pressure displays' on page 15*

Gear pump

2-stage hydraulic power packs are equipped with a gear pump on the valve block. The gear pump increases the volume flow in the low pressure range.

2.5 Display elements and controls

The hydraulic power pack is equipped with the following display elements and controls:

Control system XB32 display



The operating data and hydraulic power pack error messages are shown on the display of the XB32 control system.

Fig. 7: Control system display



Pressure displays



Fig. 8: Example, pressure gauge

There could be different pressure displays depending on the area of application:

- Digital pressure gauge
- Pressure gauge 350 bar
- Pressure gauge 800 bar

Pressure adjustment valve with adjustment lock

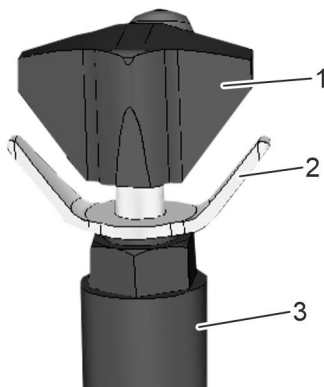

Fig. 9: Pressure adjustment valve

- 1 Knob
- 2 Adjustment lock
- 3 Pressure adjustment valve

The hydraulic pressure used to supply the connected tool is adjusted with the aid of the pressure adjustment valve.

An adjustment lock prevents the pressure being changed unintentionally. Prior to any pressure adjustment, the adjustment lock needs to be loosened and secured again after the adjustment has been made.

- ↺ Reduce pressure – turn the knob anti-clockwise
- ↻ Increase pressure – turn the knob clockwise

Pressure valve

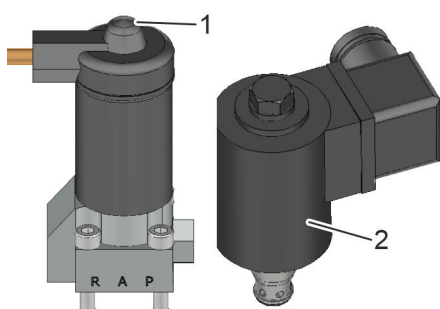

Fig. 10: Pressure valves

The main valve (Fig. 10/1) is equipped with a button that can be used to release the pressure in the respective system.

Main valve

The main valve (Fig. 10/1) switches between forward and return stroke.

Pressure relief valve

If the return stroke of the tool has been completed, the pressure relief valve switches to relief mode (release).

2.6 Operating modes

Stages

- 1-stage
- 2-stage

2-stage hydraulic power packs are equipped with a gear pump on the valve block. The gear pump increases the power of the hydraulic power pack by means of higher volume flows in low pressure ranges.

Manual

During manual bolting processes, the tool operates for as long as the relevant button on the hydraulic power pack is pressed. The maximum pressure set on the hydraulic power pack is not exceeded.

The return stroke is performed automatically when the relevant button is released.

2.7 Remote control

Remote control without display

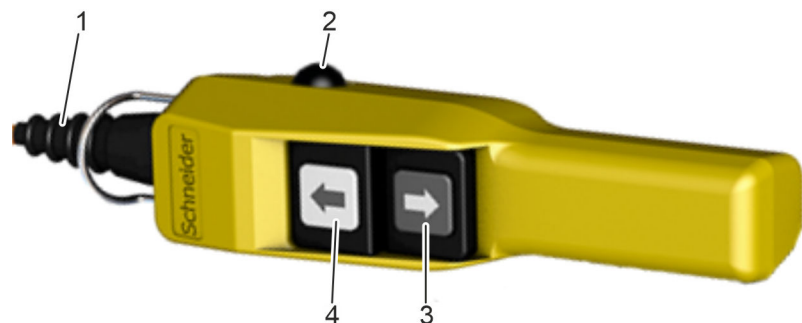

Fig. 11: Remote control without display

- 1 Cable
- 2 Red button (only with XE1hpr)
- 3 Black button
- 4 White button

2.7.1 Buttons of the remote control



XE1power, XE1 50/60Hz:

- 1. Switch on motor
- 2. Forward stroke for as long as the button is pressed, automatic return stroke when released (with option SST, only in conjunction with the SST button)

XE1hpr:

- 1. Switch on motor
- 2. Forward stroke for as long as the button is pressed. No automatic return stroke is performed!



XE1power, XE1 50/60Hz: ☹ Switch off motor

XE1hpr: Return stroke



Only available with XE1hpr: ☹ Switch off motor

2.8 Functions

Procedure

The hydraulic power pack can be used to operate hydraulic torque fastening tools up to 800 bar (XE1hpr: up to 350 bar).

2.9 Connections

Power plug



Possible power plugs:

- CEE-compliant power plugs
 - 110 V
 - 230 V
 - 3-400 V
- Others on request

Fig. 12: Example, CEE-7/7 power plug

Process connections



Various coupling/nipple versions are available for connecting the hose lines to the hydraulic power pack.

The hydraulic power pack is equipped with pressure-dependent hydraulic quick-release couplings (process connections) from Cejn, Lukas, Pioneer or Parker for 350, 700, 800, 1,500 or 2,400 bar applications as standard.

Fig. 13: Example, CEJN SE 115

2.10 Accessories



The following accessories can be ordered in addition to the hydraulic power pack and can be enclosed with the delivery:

- Transport trolley
Transport and assembly trolley for power pack, tools, and accessories
- PLARAD[®] hydraulic oil – refill canister
1, 3 or 5 litre
- Hydraulic hose
Different lengths
For different pressure rangers
- Ball valve
For shutting off the process pressure
800 bar
- Distributor
2-/3-/4-way distributor
800 bar
- 2-stage pressure valve
Enables rapid switching between two preset pressures
- Certificate (e.g. for pressure gauge)

Special accessories

Contact PLARAD[®] service.



3 Before you begin – safety

This section provides an overview of all important safety aspects for protecting personnel and for ensuring safe and fault-free operation. Further task-specific safety instructions can be found in the sections of the individual chapters.

3.1 Symbols in this manual

Safety instructions

Safety instructions are indicated by symbols in this manual. The safety instructions are initiated by signal words that indicate the degree of the danger.



DANGER!

This combination of symbol and signal word indicates an imminently dangerous situation which, if not avoided, will result in death or serious injury.



WARNING!

This combination of symbol and signal word indicates a potentially dangerous situation which, if not avoided, could result in death or serious injury.



CAUTION!

This combination of symbol and signal word indicates a potentially dangerous situation which, if not avoided, could result in slight or minor injuries.



NOTICE!

This combination of symbol and signal word indicates a potentially dangerous situation which, if not avoided, could result in damage to property.



ENVIRONMENT!

This combination of symbol and signal word indicates potential dangers to the environment.

Safety instructions in specific instructions

Safety instructions may refer to specific, individual instructions. Such safety instructions are integrated into the instruction so that they do not interrupt the flow of reading when carrying out the task. The signal words described above are used.

Example:

1.  Loosen the screw.

2. 



CAUTION!
Risk of pinching by cover!

Close the cover carefully.

3.  Tighten the screw.





Tips and recommendations



This symbol highlights useful tips and recommendations as well as information designed to ensure efficient and smooth operation.

Other markings

The following markings are used in this manual in order to highlight instructions, outcomes, lists, references and other elements:

Marking	Explanation
	Step by step instructions
	Outcomes of steps
	References to sections of this manual and to other applicable documents
	Lists without a fixed order
<i>[Button]</i>	Controls (e.g. buttons, switches), indicators (e.g. signal lamps)
<i>'Display'</i>	Display elements (e.g. on-screen buttons, assignment of function keys)
<i>'Menu' →</i> <i>'Submenu' →</i> <i>'Setting'</i>	Shortened description of navigation: Call up menu, call up submenu, change settings

3.2 Symbols on the hydraulic power pack

Overview

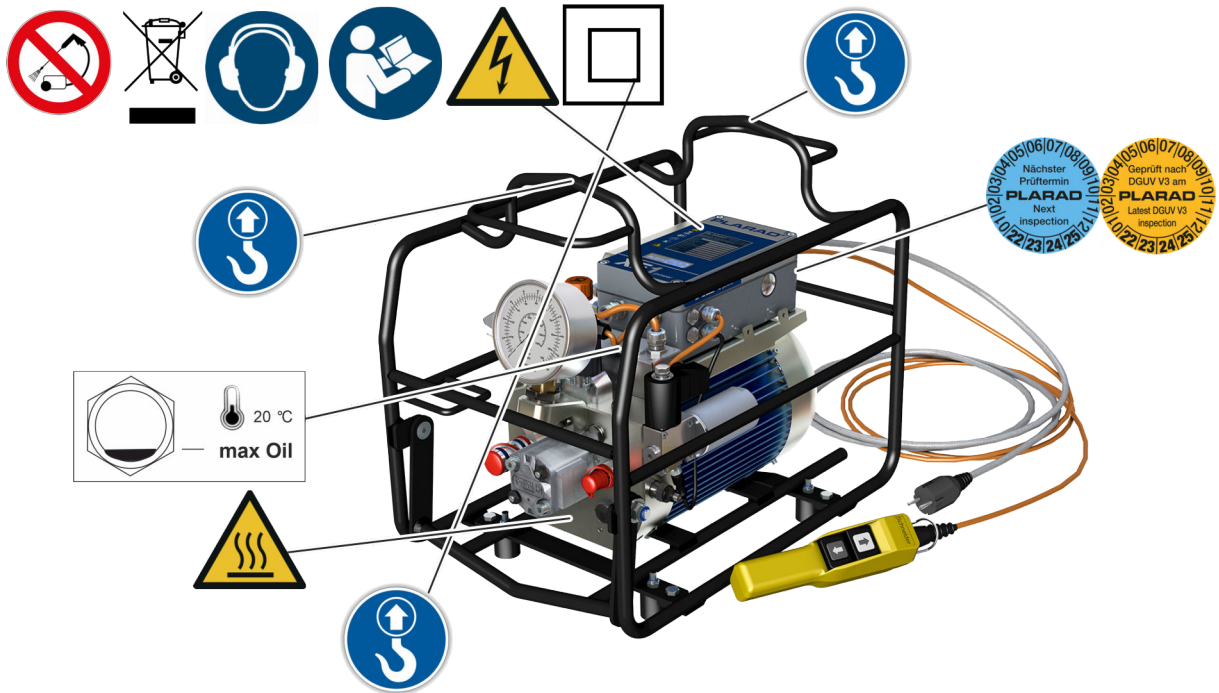

Fig. 14: Symbols on the hydraulic power pack

- | | | | |
|--|------------------------------------|--|--|
| | ↪ 'Voltage' on page 22 | | ↪ 'Separate collection' on page 22 |
| | ↪ 'Hot surface' on page 22 | | ↪ 'Test badges' on page 22 |
| | ↪ 'Follow the manual' on page 22 | | ↪ 'High-pressure cleaners prohibited' on page 23 |
| | ↪ 'Hearing protection' on page 22 | | ↪ 'Attachment point' on page 23 |
| | ↪ 'Protection class II' on page 22 | | ↪ 'Maximum oil level' on page 23 |

Illegible signage



WARNING!

Danger in the event of illegible signage!

Over time, signs and stickers can become dirty or be rendered unrecognisable by other means, such that hazards cannot be recognised and necessary operating instructions cannot be followed. This creates a danger of injury.

- Keep all safety notices, warnings and operating instructions in a clearly legible state at all times.
- Replace damaged signs and stickers immediately.

The following symbols and information notices are located on the hydraulic power pack:

Voltage



The equipment marked in this way is supplied with electrical energy.

Do not open the hydraulic power pack.

Hot surface



Hot surfaces, such as the housing of the drive motor, cannot always be identified as such. Do not touch surfaces marked in this way without protective gloves.

Follow the manual



Read the operating instructions prior to using the hydraulic power pack.

Hearing protection



Hearing protection is used to protect against hearing damage cause by noise.

Protection class II

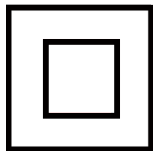

This symbol indicates protection class II. Equipment of protection class II has reinforced insulation between active and touchable parts.

Separate collection



Do not dispose of waste electronic and electrical equipment marked with this symbol in household waste.

Test badges



The test badges state the dates of the respective tests.

Date of the next PLARAD[®] service



Date of the last DGUV-V3 test

High-pressure cleaners prohibited



Do not use any high-pressure cleaners when cleaning. The pressure of the cleaning jet can result in property damage.

Attachment point



Attach the hoist only at the marked points for lifting.

Maximum oil level



The marking indicates the maximum permissible oil level at 20 °C. Never fill oil above this marking.

3.3 Intended use

The electric hydraulic power pack is a transportable, hydraulic pressure generator and may only be used to operate PLARAD[®] tools in order to produce bolted joints in line with the given specifications (↪ *Chapter 11 'Technical data' on page 61*).

The hydraulic power pack may only be used for commercial purposes and only in conjunction with PLARAD[®] hydraulic wrenches.

The hydraulic power pack is electrically powered.

The hydraulic power pack may be operated on a fixed operating network or mobile power generators, subject to compliance with the connected loads stated under ↪ *Chapter 11 'Technical data' on page 61*.

The hydraulic power pack may only be used in atmospheres that are not potentially explosive.

The hydraulic power pack may only be used in a dry environment.

Intended use includes compliance with all of the stipulations in this manual.

3.4 Misuse

Any use beyond the intended use as well as any other use is considered misuse.



WARNING!

Danger in the event of misuse!

Misuse of the hydraulic power pack can lead to dangerous situations.

- Do not operate the hydraulic power pack outside the defined specifications.
- Do not operate the hydraulic power pack in continuous operation.
- Never disregard protection classes.
- Never operate outside the permissible environmental conditions.
- Never operate with a mains voltage and mains frequency other than those specified on the rating plate.
- Do not switch on the nutrunner in a damp environment.
- Never operate in a potentially explosive atmosphere.

3.5 Residual risks

The following section outlines the residual risks potentially posed by the hydraulic power pack even when it is used as intended.

To reduce the risks of personal injury and property damage and to avoid dangerous situations, observe the safety instructions listed here and the safety instructions in the other sections of this manual.



3.5.1 Electrical dangers

Electrical current



DANGER!

Danger of death due to electric shock!

Touching live parts poses an immediate danger of death due to electric shock. Damage to the insulation or individual components can be life-threatening.

- Do not open the housing of electrical components.
- In the event of damage, disconnect the hydraulic power pack from the power supply immediately and arrange for repair.
- Keep moisture away from live parts. Moisture can cause short circuits.
- Never operate with a mains voltage and mains frequency other than those specified on the rating plate.
- Ensure that the power supply complies with local regulations.
- Never make modifications to the hydraulic power pack.
- Never modify the power plug or power cable.
- Only operate at suitable power sockets.
- Never operate after the inspection period has elapsed. See the test seal for the date of the next test.
- Never operate in a potentially explosive atmosphere.
- Keep away from moisture, liquids, steam, dust and coarse contamination.
Do not switch on in a damp environment or in the rain.
- If possible, operate with a residual current-operated circuit breaker installed.
- Avoid making physical contact with earthed components.

Faulty power cable



DANGER!

Danger of death due to faulty power cable!

Faulty power cables can lead to a direct danger of death from electric shock.

Rolled-up power cables can result in thermal overload and could catch fire.

- Never modify the power plug or power cable.
- Only operate at suitable power sockets.
- Prior to every use, check the power cable for visible damage to the insulation.
Never replace the power cable yourself.
- Do not crush, shear or overload the power cable (pressure, strain).
- Do not pull on the power cable in order to disconnect the power plug from the power socket.
- Prior to switching it on, always unwind the power cable fully.
- Do not route the power cable over sharp edges, pinch points, through water, oil or other chemicals.
- Do not kink the power cable and do not twist it.
- Do not route the power cable close to moving parts or hot surfaces, such as motors or exhaust lines of mobile power generators.
- Wherever possible, do not expose the power cable to constant sunlight or other forms of UV radiation.
- Do not wrap the power cable around the hydraulic power pack.
- Ensure that extension cables routed outdoors or through humid environments are approved for the ambient conditions.
- Ensure that supply lines have the minimum permissible cross-section.



3.5.2 Danger due to hydraulics

Pressurised hydraulic fluid



WARNING!

Pressurised hydraulic components could result in life-threatening injuries!

Inadvertent opening or defects could result in the discharge of hydraulic fluid under high pressure.

Hydraulically powered drives could move unexpectedly.

Contact with hot hydraulic oil could result in severe burns.

- Prior to commencing all work, check the hydraulic power pack, connections, hoses and tools for visible damage and leaks. Have all identified defects remedied immediately.
- Prior to commencing work on the hydraulic system, first switch it off, then depressurise it and let it cool down. Fully relieve all accumulators of pressure. Check to ensure a depressurised state.
- Do not change pressure settings such that they exceed the maximum values.
- Comply with the maintenance intervals.
- Always ensure that hydraulic hoses are properly connected and locked. Quick-release couplings must be engaged. Bolted connections must be fully secured.

Exceeding the maximum pressure



WARNING!

Danger of bursting due to excessive hydraulic pressure!

If the hydraulic pressure exceeds the maximum permissible pressure for connections, hoses, tools or components of the hydraulic power pack, these could burst. Airborne parts and hydraulic fluid discharged under high pressure could cause serious injuries.

- Ensure that all components are designed for the maximum applied hydraulic pressure and that none of the components are damaged.
- Check for defects, damage and leaks. Have all identified defects remedied immediately.
- Comply with the maintenance intervals.

Hydraulic oil



WARNING!

Damage to health and secondary illnesses due to contact with hydraulic oil!

Contact with hydraulic oil could cause allergic reactions, skin and eye irritation, nausea and other secondary illnesses.

- Wear personal protective equipment for all work with hydraulic oil.
- Do not eat, drink or smoke in areas in which work involving hydraulic oil is performed.
- Upon completion of the work, clean or dispose of clothing and personal protective equipment contaminated with hydraulic oil in the proper manner.
- Note the safety data sheet for the hydraulic oil in use.

Oil specifications



NOTICE!

Property damage due to non-compliance with the oil specifications!

Incorrect hydraulic oils, an incorrect oil level and the use of contaminated hydraulic oils could result in property damage. If hydraulic oil overflows due to the oil level being too high, this could result in environmental damage.

- Check and correct the oil level as follows as a minimum requirement:
 - In the course of commissioning
 - After connecting/disconnecting the hydraulic hoses
 - After flushing
 - After transport, maintenance, repair, troubleshooting
- Top up using only new and clean hydraulic oil ☞ *'Oil specifications' on page 62.*
- Fill hydraulic oil via a funnel with an oil filter.
- Always pay attention to the maximum oil level marking (see sticker).
- Comply with the maintenance intervals.



3.5.3 Mechanical dangers

Moving components and rotational movements



WARNING!

Danger of injury due to moving components!

Moving components and tools could cause serious injuries. There is a danger of being pulled in during rotational movements.

- During operation, do not reach into moving components or handle moving components.
- Prior to commissioning, secure the reaction arm, impact wrench socket and other such tool components in the proper manner.
- Do not switch on the nutrunner while carrying it.
- Wear tight fitting work clothing with a low tearing resistance.
- Wear safety goggles.
- Wear a protective cap (hair net) to prevent long hair from being pulled in by rotating parts.

Crushing



WARNING!

Danger of crushing due to high weight!

The high weight can cause crushing if it falls down.

- Handle the hydraulic power pack with care and as intended.
- Give due consideration to the weight during transport and during all work.
- Carry with the aid of a second person or use suitable hoists.
- Secure the hydraulic power pack against falling when working at height.
- Wear safety shoes.
- Always set up the hydraulic power pack securely.
- Put the hydraulic power pack with all its four feet on firm and level ground.

Dirt and scattered objects



CAUTION!

Danger of injury from falling over dirt and scattered objects!

People may slip on or stumble over dirt and scattered objects. Falling may cause injuries.

- Always keep the work area clean.
- If objects are no longer needed, remove them from the work area and especially if such objects are at ground level.
- Mark unavoidable stumbling points with hazard tape.

3.5.4 Noise and ergonomics

Noise



WARNING!

Danger of injury due to noise!

The noise level of 89 dB(A) (3 dB(A) measurement uncertainty) occurring in the work area can cause hearing damage.

- Always wear hearing protection when working.
- Remain in the danger zone only for as long as your presence is required.
- Set up the hydraulic power pack as far away from the operating site of the tool as possible.

Hot surfaces



WARNING!

Danger of injury due to hot surfaces!

The surfaces of components, such as the drive motor or gearbox, could heat up significantly during operation. Surface temperatures of up to 80 °C could develop. Contact between the skin and hot surfaces will result in severe burns to the skin.

- Always wear heat-resistant protective work clothing and safety gloves when working in the vicinity of hot surfaces.

**Inattention****WARNING!****Danger of injury due to distraction, inattention or irresponsible use!**

Distraction, inattention or irresponsible use can result in losing control of the hydraulic power pack and thus cause serious injuries.

- Always keep the work area well-lit when working on the hydraulic power pack.
- Keep children and unauthorised persons away.
- Work purposefully and in a responsible manner. Do not allow yourself to be distracted.
- Do not work if you are tired or under the influence of drugs, alcohol or medicine.
- Do not be lulled into a false sense of security. Do not disregard the safety information and instructions in this manual, even if the hydraulic power pack seems familiar to you after frequent use.
- When the hydraulic power pack is not in use, always store it safely out of reach of unauthorised persons.
- Wear the prescribed personal protective equipment.

Faulty safety devices**WARNING!****Danger of death due to inoperative safety devices!**

If safety devices or safety functions are inoperative or disabled, there is a danger of serious injuries.

- Prior to commencing work, check that all safety devices are operative and correctly installed.
- Never disable or bypass safety devices or safety functions.

The hydraulic power pack is equipped with the following safety devices and safety functions:

- Insulation of the power cable
- Protection class 2

A residual current-operated circuit breaker must be installed by the operator.

Monitoring of the mains voltage and frequency

Overvoltage and undervoltage

The hydraulic power pack cannot be switched on or is switched off automatically.



Nevertheless, overvoltage can lead to the destruction of input components.

The error is displayed. The hydraulic power pack cannot be switched on again until the correct mains voltage has been restored.

Monitoring of the motor current

The motor current is monitored. The motor is switched off if values are incorrect. The power pack needs to be disconnected from the mains. Recommissioning is not possible until this has been done.

Monitoring of the motor oil temperature

The temperature of the motor oil is monitored. The motor is switched off if the motor oil temperature is too high. The power pack cannot be switched on again until the motor oil temperature has dropped below a set threshold.

Monitoring of the pressure

The hydraulic pressure is monitored with regard to exceedance of a parametrised maximum value. The motor is switched off if the value is exceeded. The power pack needs to be disconnected from the mains. Recommissioning is not possible until this has been done.



3.6 Operator's obligations

The hydraulic power pack is used in the commercial sector. The operator of the hydraulic power pack is therefore subject to the statutory obligations pertaining to occupational safety.

In addition to the safety instructions in this manual, the applicable safety, occupational safety and environmental protection regulations for the hydraulic power pack's area of application must be adhered to.

The following specifically applies in this regard:

- Operators must familiarise themselves with the applicable occupational safety regulations and, as part of a risk assessment, determine additional dangers that arise as a result of the specific operating conditions at the operating site of the hydraulic power pack. This risk assessment must be implemented in the form of safety instructions for operation of the hydraulic power pack.
- During the entire time the hydraulic power pack is in use, the operator must check whether the safety instructions they have compiled reflect current regulations and, if necessary, the operator must change the instructions accordingly.
- The operator must clearly define and regulate responsibilities for all work on and with the hydraulic power pack. The authority and responsibilities of personnel regarding operation, set-up, maintenance and repair must be clearly defined.
- The operator must reliably check the use of the hydraulic power pack and ensure that only commissioned and instructed personnel work with the hydraulic power pack. Personnel being trained or instructed and personnel undertaking vocational training must always be supervised by an experienced person when working on the hydraulic power pack.
- The operator must ensure that no unauthorised persons open the hydraulic power pack or perform work on the electrical or hydraulic equipment.

Work on electrical equipment may only be performed by an electrician or by trained persons under the guidance and supervision of an electrician. Adhere to electrotechnical regulations for safety reasons.

The operator is also responsible for ensuring that the hydraulic power pack is in technically flawless condition at all times. The following applies for this reason:

- The operator must ensure adherence to the maintenance intervals described in this manual.
- The operator must have the functionality and integrity of all safety devices checked on a regular basis.
- Some parameters are set by the manufacturer prior to initial commissioning, e.g. some valve settings. The operator must ensure that these parameters are not changed.

3.7 Who may use the hydraulic power pack?



WARNING!

Danger of injury if personnel are insufficiently qualified!

If unqualified personnel perform work on or with the hydraulic power pack or if such persons are present in the danger zone while work is being performed, dangers arise that could cause serious injuries and considerable property damage.

- Have all tasks performed by suitable qualified personnel without exception.
- Keep unqualified personnel away from the danger zones and work areas.

User

Users of the hydraulic power pack have the requisite knowledge and the requisite training for handling electric power generators. Furthermore, as part of training provided by the operator, users have been trained in relation to the tasks assigned to them and the potential dangers associated with improper conduct.

Users are trained in how to use the personal protective equipment, are familiar with the most important specifications, situations and information relating to working with electric and hydraulic systems and are capable of using the hydraulic power pack safely. This includes connecting and flushing hydraulic hoses.

Users must satisfy the legal minimum age requirements.

Users may only perform tasks that exceed operation under normal operating conditions if this is specified in this manual and the operator has expressly entrusted the users with the performance of such tasks.

Users know who their supervisor is, can contact their supervisor if they have questions or in an emergency, and are able to communicate with their supervisor.

The user is familiar with all residual risks and is trained in the practical handling of the hydraulic power pack.

Qualified hydraulic power pack personnel

Qualified hydraulic power pack personnel are trained for the specific task area in which they work and are familiar with the relevant standards and regulations.

Due to their professional training and experience, qualified hydraulic power pack personnel are able to perform work with the hydraulic power pack, recognise and avoid potential dangers independently and convey this to users.

Specific capabilities of qualified hydraulic power pack personnel include:

- Use all functions of the hydraulic power pack.
- Create passwords for users.
- Uphold safety, occupational safety and health protection when using the hydraulic power pack and convey this to users.



- Identify damage on the hydraulic power pack and arrange for repairs or get in touch with the manufacturer.
- Instruct users in the proper manner.

Operator

Operators are persons who operate the hydraulic power pack for commercial or economic purposes themselves, or make it available for a third party to use, and who bear legal responsibility for the product vis-à-vis protection of personnel and third parties during operation.

🔗 *Chapter 3.6 'Operator's obligations' on page 33*

PLARAD[®] service

Certain work may only be performed by PLARAD[®] service or by personnel authorised by Maschinenfabrik Wagner GmbH & Co. KG. Other personnel are not authorised to perform this work. Contact PLARAD[®] service or authorised PLARAD[®] partners regarding performance of the work that is due.

Contact: www.plarad.de

🔗 *Chapter 8.4 'Having service tasks performed by the manufacturer' on page 56*

Unauthorised persons



WARNING!

Danger of death for unauthorised persons due to dangers in the danger zone and work area!

Unauthorised persons, who do not meet the requirements described in this manual, are not aware of the dangers in the danger zone. There is therefore a danger of serious injuries or even death for unauthorised persons.

- Keep unauthorised persons away from the danger zone and work area.
- If in doubt, address the respective persons and instruct them to leave the danger zone and work area.
- Suspend work while there are unauthorised persons loitering in the work and danger zone.

3.8 Personal protective equipment

Safety gloves



Safety gloves are used to protect the hands from friction, abrasions, punctures or deeper injuries and from contact with hot surfaces.

Safety shoes



Safety shoes protect the feet from crushing, falling parts and from slipping on slippery ground.

Hearing protection



Hearing protection is used to protect against hearing damage cause by noise.

Safety goggles



Safety goggles are used to protect the eyes from airborne parts and liquid jets.

Protective work clothing



Protective work clothing is tight fitting work clothing with a low tearing resistance, with tight sleeves and without any protruding parts.

Industrial safety helmet



Industrial safety helmets are used to protect the head from falling objects, suspended and swinging objects and from bumping into stationary objects.

An industrial safety helmet must be worn for overhead work involving the nutrunner.



3.9 Environmental protection



ENVIRONMENT!

Danger for the environment due to incorrect handling of environmentally hazardous substances!

If environmentally hazardous substances are handled incorrectly, especially if such substances are disposed of incorrectly, this could cause significant damage to the environment.

- Always adhere to the instructions given below in relation to the handling of environmentally hazardous substances and the disposal thereof.
- If environmentally hazardous substances accidentally enter the environment, adopt suitable measures immediately. If in doubt, notify the competent local authority of the damage and inquire about suitable measures to be taken.

The following environmentally hazardous substances are used:

Lubricants

Lubricants, such as greases and oils, contain toxic substances. Such substances must not enter the environment.

Electrical and electronic components

Electrical and electronic components contain toxic materials. These components must be collected separately and deposited at municipal collection points or be disposed of by a specialist company.

Hydraulic oil

Hydraulic oil can contain harmful and environmentally hazardous substances. It must not enter the environment (soil, water), sewage system or household waste. Dispose of hydraulic oil and waste containing hydraulic oil separately via an approved disposal company.

Observe the manufacturer's safety data sheet.

4 Choosing the installation site

Incorrect installation site



WARNING!

Danger of injury due to careless choice of installation site!

Risks could arise from the choice of installation site. If the hydraulic power pack falls, this could result in serious crushing. The noise emissions could cause hearing damage.

- Adhere to the following principles when choosing the installation site.

Installation site

- Personnel: ■ User
- Protective equipment: ■ Protective work clothing
■ Safety gloves
■ Safety shoes

1. ▶ Ensure that the ambient conditions are adhered to:

- ↻ Chapter 11 'Technical data' on page 61
- Not a potentially explosive atmosphere
- Dry

2. ▶



ENVIRONMENT!

Environmental damage due to oil leakage!

Ensure that the hydraulic power pack is horizontal.

3. ▶



WARNING!

Danger of crushing due to falling or moving hydraulic power pack!

Ensure that the hydraulic power pack cannot fall from elevated installation sites or slide out of position. If there is any doubt, secure the hydraulic power pack against falling.

4. ▶ Note the maximum power cable length.

5. ▶ Note the maximum remote control cable length.

6. ▶



WARNING!

Hearing damage due to noise!

As far as possible, install the hydraulic power pack in such a way that the noise emissions do not affect the workplace. Note the maximum remote control cable length.



7. → Check the stability.

5 Supplying with energy

Electrical current



DANGER!

Danger of death due to electric shock!

Touching live parts poses an immediate danger of death due to electric shock. Damage to the insulation or individual components can be life-threatening.

- If the housing is damaged, disconnect it from the power supply immediately and arrange for repair.
- Keep moisture away from live parts. Moisture can cause short circuits.
- Never operate with a mains voltage and mains frequency other than those specified on the rating plate.
- Ensure that the power supply complies with local regulations.
- Never modify the power plug or power cable.
- Only operate at suitable power sockets.
- Never operate after the inspection period has elapsed. See the test seal for the date of the next test.
- Keep away from moisture, liquids, steam, dust and coarse contamination.
Do not switch on in a damp environment or in the rain.
- Avoid making physical contact with earthed components.
- During operation with mobile power generators, ensure continuous and constant compliance with the specified values for voltage, frequency, sufficient power and earthing.



Faulty power cable



DANGER!

Danger of death due to faulty power cable!

Faulty power cables can lead to a direct danger of death from electric shock.

Rolled-up power cables can result in thermal overload and could catch fire.

- Never modify the power plug or power cable.
- Only operate at suitable power sockets.
- Prior to every use, check the power cable for visible damage to the insulation.
Never replace the power cable yourself.
- Do not crush, shear or overload the power cable (pressure, strain).
- Do not pull on the power cable in order to disconnect the power plug from the power socket.
- Prior to switching it on, always unwind the power cable fully.
- Do not route the power cable over sharp edges, pinch points, through water, oil or other chemicals.
- Do not kink the power cable and do not twist it.
- Do not route the power cable close to moving parts or hot surfaces, such as motors or exhaust lines of mobile power generators.
- Wherever possible, do not expose the power cable to constant sunlight or other forms of UV radiation.
- Do not wrap the power cable around the hydraulic power pack.
- Ensure that extension cables routed outdoors or through humid environments are approved for the ambient conditions.
- Ensure that supply lines have the minimum permissible cross-section.

- Personnel: ■ User
- Protective equipment: ■ Protective work clothing
■ Safety gloves
■ Safety shoes

The hydraulic power pack needs to be supplied with electrical power prior to use.

Power supply

1. ➤ Ensure that the available electrical power supply complies with the device's electrical connected loads ↪ *Chapter 11 'Technical data' on page 61.*



Consult an electrician if you have any questions. Never make changes or perform repair work on the electrical system yourself.

Connecting cable

2. ➤ Have a suitable connecting cable ready for the operating site.
3. ➤ Ensure that there is no damage on the hydraulic power pack, on the power cable, on the connecting cable, on the power plug or on the power socket.
4. ➤ Lay connecting cables in such a way that no tripping hazards arise, no mechanical load occurs, no sharp corners or edges can damage the insulation and that the ambient conditions correspond to the operating conditions for the connecting cables. Completely unwind the connecting cables if they are on a reel.
5. ➤ Have the hydraulic power pack ready at the operating site. When doing so, ensure that ambient conditions correspond to the specifications ↪ *Chapter 11 'Technical data' on page 61.*

Connection

6. ➤ Plug the connecting cable's plug into the power socket and connect the power cable of the hydraulic power pack to the connecting cable.
⇒ The hydraulic power pack is electrically connected.



6 Preparing for operation

6.1 Prior to switching on

- Personnel: ■ User
- Protective equipment: ■ Protective work clothing
 ■ Safety goggles
 ■ Safety gloves
 ■ Safety shoes

Installation

1. ➔ Install the hydraulic power pack securely (☞ *Chapter 4 'Choosing the installation site' on page 38.*)
2. ➔ Check for leaks. If the hydraulic power pack is damaged, do not put it into service.

Oil level



Fig. 15: "max Oil" sticker

3. ➔



WARNING!

Danger of burns and environmental damage due to hydraulic oil!

Hydraulic oil expands when it heats up during operation. If filled above the marking, hydraulic oil could escape from the sealing plug. Contact with hot oil could result in burns. If hydraulic oil escapes, this could result in environmental damage.

Check the oil level in the sight glass to ensure it matches the "max Oil" sticker. In doing so, ensure that the hydraulic power pack is horizontal so that the correct value can be read.

The "max Oil" sticker indicates the intended maximum oil level in the surge tank when the hydraulic power pack has cooled down (20 °C).

4. ➔ Top up the oil if the display and oil level in the sight glass do not match.
 To do so, open the cover of the oil filling neck.
5. ➔ Fill hydraulic oil (☞ *'Oil specifications' on page 62*) through an oil filter and into the surge tank until the oil level in the sight glass matches the marking on the "max Oil" sticker.
6. ➔ Mop up any spilled hydraulic oil in the proper manner and clean the work environment.
 ⇨ The hydraulic power pack can be started.

6.2 Starting the hydraulic power pack

- Personnel: ■ User
- Protective equipment: ■ Protective work clothing
 ■ Safety goggles
 ■ Safety gloves
 ■ Safety shoes

Power supply

→  **DANGER!**
Danger of death due to improperly secured mains connection!

Safeguard the power supply ↪ *Chapter 5 'Supplying with energy' on page 40.*

⇒ The hydraulic power pack starts with a self-test.

Control system XB32 display

If the hydraulic power pack is not connected to the power supply, the hydraulic power pack starts automatically.

The following information can be shown on the display:



- Start screen
- Control system logo
- Control system revision number
- Mains frequency
- Maximum power consumption
- Operating hours
- Current power consumption
- Current oil temperature



- Error display including the error code

Self-test

Error messages may be displayed briefly during the self-test. These messages disappear again upon successful completion of the test.

- ➔ If the error messages continue to be displayed after the self-test, send the hydraulic power pack to PLARAD[®] service.

6.3 Using the hydraulic power pack at low temperatures

- Personnel:
 - User
- Protective equipment:
 - Protective work clothing
 - Safety goggles
 - Safety gloves
 - Safety shoes

Proceed as follows in relation to operation below -5 °C:

Starting multiple times

1. ➔ If need be, start the hydraulic power pack multiple times until the drive motor is running.
2. ➔ Set the pressure relief valve to 400 bar ↗ *Chapter 6.5 'Setting the operating pressure' on page 47.*

Bring the hydraulic power pack to operating temperature

3. ➔

 *Do not connect any hydraulic hoses or tools.*

Press and hold the white button for 5 minutes to let the hydraulic power pack run.

- ⇒ The hydraulic oil is brought to operating temperature.

6.4 Connecting the hose

- Personnel: ■ User
- Protective equipment: ■ Protective work clothing
 ■ Safety goggles
 ■ Safety gloves
 ■ Safety shoes

Period of use

1. ➤ Ensure that the hydraulic hoses have not exceeded the maximum period of use.



Hose check:

- The maximum period of use must not be exceeded.
Comply with the exchange interval. Use for a maximum of 5 years.
- The maximum pressure must not be reached.
- Use filled hydraulic hoses only.
- Oil specifications must match.
- Couplings and nipples must be compatible and be undamaged.
- There is no visible damage.

Coupling

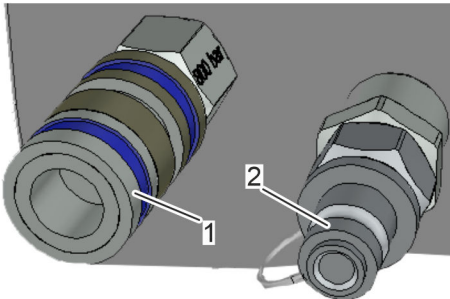

Fig. 16: Example, coupling (1) – nipple (2)

2. ➤



The hydraulic power pack can be equipped with various coupling systems.

The pressure connection is the connection on the hydraulic power pack that is fitted with a coupling.

Ensure that the coupling/nipple combination is suitable and free of damage.

Ensure that the maximum permissible pressures of all components are sufficient.

Ensure that the hydraulic hose is fully filled with suitable hydraulic oil ☞ 'Oil specifications' on page 62.

Connect the hydraulic hoses to the hydraulic power pack.

Check the lock.



Older couplings have counter-threads.
Tighten to lock.

New couplings have a bayonet closure. Let it fully engage.

3. ➤ Do not connect the tool yet.
4. ➤ Flush ☞ Chapter 6.6 'Flushing' on page 48.

Flushing



Sequence



Connect hydraulic hoses only in a depressurised state!

The motor may run.

Adhere to the following sequence when connecting the tools:

1. - Hydraulic power pack pressure connection
2. - Tool pressure connection
3. - Hydraulic power pack return
4. - Tool return

6.5 Setting the operating pressure

- Personnel: ■ User
- Protective equipment: ■ Protective work clothing
- Safety goggles
- Safety gloves
- Safety shoes

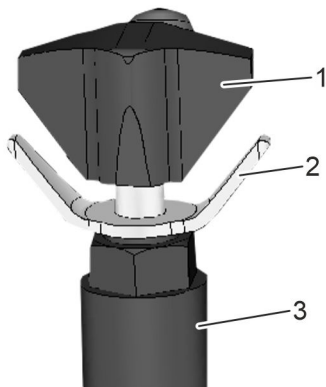

Fig. 17: Pressure adjustment valve

- 1 Knob
- 2 Adjustment lock
- 3 Pressure adjustment valve

1. ➔ Read the pressure to be set from the torque chart/tensile force chart for the tool.
2. ➔ Release the adjustment lock (Fig. 17/2). To do so, turn it anti-clockwise.
3. ➔ Turn the knob (Fig. 17/1) anti-clockwise. Open completely.
4. ➔ Start the hydraulic power pack with the remote control. Press the white button to start the motor.

5. ➔



WARNING!

Danger of injury from exceeding the maximum permissible tool pressure!

Set the pressure during the forward stroke. To do so, slowly turn the knob clockwise. Note the pressure display.

⇒ The pressure is increased.

6. ➔ Activate the forward stroke again if the maximum forward stroke time is exceeded. To do so, release the button and press it again.
7. ➔ Save the setting when the desired pressure is reached. To do so, turn the adjustment lock clockwise until the knob is secured.

6.6 Flushing

- Personnel: ■ User
- Protective equipment: ■ Protective work clothing
 ■ Safety goggles
 ■ Safety gloves
 ■ Safety shoes

To prevent air pockets, the hoses need to be flushed prior to use.

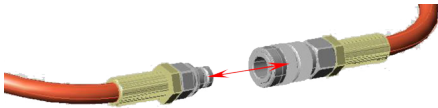

Fig. 18: Flushing



1. ➤ Ensure that the hydraulic hoses are properly connected
 ↪ Chapter 6.4 'Connecting the hose' on page 46.
2. ➤ Connect the hydraulic hoses together at the ends. For tandem use, connect both pairs of hoses together.
3. ➤ Press the white button to switch on the hydraulic power pack.
 - ⇒ The hydraulic power pack starts.

As the hydraulic power pack performs a return stroke after every start and no pressure can build up via the connected hydraulic hoses, this return stroke is never completed.

The ongoing return stroke ensures that the hydraulic hoses are flushed. Any air pockets present are cleared from the hoses.
4. ➤ Let it run for at least 30 seconds (for a standard hose length of 4 m).
5. ➤ Check for leaks. Replace the hydraulic hoses if there are any leaks.
6. ➤ Switch off the hydraulic power pack.
 - XE1power: Press the black button to switch off the motor.
 - XE1hpr: Press the red button to switch off the motor.
7. ➤ Disconnect the ends of the hydraulic hoses.
 - ⇒ The hydraulic power pack is operational.



7 Working with hydraulic wrenches

Exceeding the maximum pressure



WARNING!

Danger of bursting due to excessive hydraulic pressure!

If the hydraulic pressure exceeds the maximum permissible pressure for connections, hoses, tools or components of the hydraulic power pack, these could burst. Airborne parts and hydraulic fluid discharged under high pressure could cause serious injuries.

- Ensure that all components are designed for the maximum applied hydraulic pressure and that none of the components are damaged.
- Check for defects, damage and leaks. Have all identified defects remedied immediately.
- Comply with the maintenance intervals.

- Personnel: ■ User
- Protective equipment: ■ Protective work clothing
- Safety goggles
- Safety gloves
- Safety shoes

Installation

1. ➤ Install the hydraulic power pack securely ↗ *Chapter 4 'Choosing the installation site' on page 38.*

Power supply

2. ➤ Supply the hydraulic power pack with power ↗ *Chapter 5 'Supplying with energy' on page 40.*

Oil level

3. ➤ Check the oil level ↗ *'Oil level' on page 43.*

Starting

4. ➤ Press the white button on the remote control.
⇒ The hydraulic power pack starts.

Leaks

5. ➤ Check again for leaks and ensure that the oil level is correct. Correct the oil level if necessary.

Stopping

6. ➤ Switch off the hydraulic power pack.
XE1power, XE1 50/60Hz: Press the black button to switch off the motor.
XE1hpr: Press the red button to switch off the motor.

Connecting the hoses

7. ➤ Check the hydraulic hose and couplings for leaks. Note the maximum period of use. Do not use the hydraulic hose if there are leaks or if the maximum period of use is exceeded ↗ *Chapter 6.4 'Connecting the hose' on page 46.*

8. ➤ Ensure that the hydraulic hose is fully filled with the specified hydraulic oil ↗ *'Oil specifications' on page 62.*

- 9.** ▶ First connect the pressure side. Connect the couplings in the proper manner. Let the circlip lock in place or secure the bolted connection.



The hydraulic connections of the hydraulic power pack and the hydraulic hose must be compatible.

- 10.** ▶ Connect the hydraulic hose for the return.
- 11.** ▶ Check the connections for leaks and reconnect them if there are leaks.
- 12.** ▶ Flush ↪ *Chapter 6.6 'Flushing' on page 48.*
- 13.** ▶ Ensure that the fastening operation is known.
- 14.** ▶ Read the required pressure from the torque chart for the tool (↪ Operating instructions for the tool) and set it ↪ *Chapter 6.5 'Setting the operating pressure' on page 47.*
- 15.** ▶ Connect the tool ↪ Operating instructions for the tool.

Flushing

Setting the pressure

Hydraulic wrench

7.1 Manual operation – tightening

- Personnel: ■ User
- Protective equipment: ■ Protective work clothing
■ Safety goggles
■ Safety gloves
■ Safety shoes

- 1.** ▶ Ensure that the correct pressure is set ↪ *Chapter 6.5 'Setting the operating pressure' on page 47.*
- 2.** ▶ Attach the tool to the bolt in the proper manner.
- 3.** ▶ Press the white button.
⇒ The tool rotates the bolt.
- 4.** ▶ Ensure that the tool is rotating in the tightening direction. Rotate the tool if the bolt is loosened.
- 5.** ▶ Release the white button.
⇒ XE1power, XE1 50/60Hz: The tool retracts.
- 6.** ▶ XE1hpr: Press the black button to perform the return stroke.
- 7.** ▶ Press and hold the button and release it again until there is no further visibly discernible rotation of the tool.



XE1hpr: After releasing the white button, press the black button to perform the return stroke.



- 8.** ➤ XE1*power*, XE1 50/60Hz: Press the black button to switch off the hydraulic power pack after establishing the bolted connection.

XE1*hpr*: Press the red button to switch off the hydraulic power pack after establishing the bolted connection.

7.2 Manual operation – loosening

- Personnel: ■ User
- Protective equipment: ■ Protective work clothing
 ■ Safety goggles
 ■ Safety gloves
 ■ Safety shoes

- 1.** ➤ Ensure that the correct pressure is set ↪ Chapter 6.5 'Setting the operating pressure' on page 47.

- 2.** ➤ Attach the tool to the bolt in the proper manner.



- 3.** ➤ Press the black button.

⇒ The tool rotates the bolt.



- 4.** ➤ Press the white button.

⇒ The tool rotates the bolt.

- 5.** ➤ Ensure that the tool is rotating in the loosening direction. Rotate the tool if the bolt is tightened.

- 6.** ➤ Release the white button.

⇒ XE1*power*, XE1 50/60Hz: The tool retracts.

- 7.** ➤ XE1*hpr*: Press the black button to perform the return stroke.

- 8.** ➤ Press and hold the button and release it again until the bolt is loosened.

XE1*hpr*: After releasing the white button, press the black button to perform the return stroke.

- 9.** ➤ XE1*power*, XE1 50/60Hz: Press the black button to switch off the hydraulic power pack after loosening.

XE1*hpr*: Press the red button to switch off the hydraulic power pack after loosening.

8 Performing maintenance

8.1 Maintenance schedule

Improperly performed maintenance tasks



WARNING!

Danger of injury from improperly performed maintenance tasks!

Improper maintenance can cause serious injuries and significant property damage.

- Ensure sufficient assembly space prior to commencing the tasks.
- Ensure that the assembly site is clean and tidy. Loosely stacked or randomly scattered components and tools may cause accidents.
- Only permit users to perform the following maintenance activities: “ensure correct oil level”, “clean”, “ensure compliance with maximum period of use for hydraulic hoses”, “change oil” and “have checked for damage”.
- Have all repairs performed by the manufacturer.
- Never open components of the hydraulic power pack.
- Use only PLARAD[®] original parts.

Faultless operation

The following sections describe the maintenance tasks that are required in order to ensure optimum and faultless operation.

If routine checks reveal increased wear, shorten the requisite maintenance intervals according to the actual signs of wear. If you have questions about maintenance tasks and intervals, contact PLARAD[®] service.

Interval	Maintenance task	Personnel
Before and after every use	<ul style="list-style-type: none"> ■ Check the oil level. ■ Clean. ■ Check surfaces, warning symbols and pictograms for damage. ■ Check the power cable, power plug and fasteners for damage. ■ Check for leaks and visible damage. ■ Ensure that the maximum period of use for the hydraulic hoses has not been reached. Note the exchange intervals for the hydraulic hoses. See the hose manufacturer's specifications. <p>↪ Chapter 8.2 'Having the hydraulic power pack maintained by the user' on page 54</p>	User
After 150 operating hours or yearly	<ul style="list-style-type: none"> ■ Change the oil ↪ Chapter 8.3 'Changing the oil' on page 55. 	User



Interval	Maintenance task	Personnel
<p>Every 3 months</p> <ul style="list-style-type: none"> ■ In the event of extreme operating conditions (e.g. dust, dirt) ■ In the event of high frequency of use, multi-shift operation 	<ul style="list-style-type: none"> ■ Oil-immersed motor Perform service as stipulated by the motor manufacturer. ■ Perform the software update. ■ Gearbox Perform service as stipulated by the manufacturer. ■ Change the oil filter. ■ Change the hydraulic oil. ■ Replace wear parts such as seals. ■ Exchange damaged markings. ■ Test as per DGUV Regulation 3. ■ Accessories Check for damage; exchange. <p>🔗 <i>Chapter 8.4 'Having service tasks performed by the manufacturer' on page 56</i></p>	<p>PLARAD[®] service</p>
<p>Every 6 months</p> <ul style="list-style-type: none"> ■ In the event of standard operating conditions ■ In the event of average frequency of use 		
<p>Every 12 months</p> <ul style="list-style-type: none"> ■ In the event of low frequency of use 		

Accessories, spare parts and wear parts

Spare parts must meet the technical requirements specified by PLARAD[®]. This is always ensured by original spare parts. A warranty can only be provided for original spare parts supplied by PLARAD[®].

The installation or use of other spare parts can, under certain circumstances, adversely alter the specified design properties and, consequently, impair active or passive safety.

Any liability and warranty for damage resulting from the use of parts other than the original spare parts and accessory parts is excluded.

Have at least the following information about the hydraulic power pack to hand to enable quick and easy processing:

- Client
- Serial number
- Desired spare part
- Desired quantity
- Desired mode of shipping



🔗 *'PLARAD[®] service' on page 4*

8.2 Having the hydraulic power pack maintained by the user

Personnel: ■ User

Perform the following maintenance steps before and after every use:

Oil level

1.  Check the oil level. Top up the oil if the depiction of the “max Oil” sticker and the oil level in the sight glass do not match  Chapter 6 ‘Preparing for operation’ on page 43.

Cleaning

2. 



NOTICE!

Property damage due to improper cleaning!

Clean the hydraulic power pack with a soft cloth. Never use strong cleaning agents, water, brushes, sharp-edged tools or high-pressure cleaners.



WARNING!

Fire hazard!

When using isopropyl alcohol, do not clean the hydraulic power pack near ignition sources. Do not smoke. Let it evaporate.

Surfaces and markings

3.  Check surfaces and markings for damage. Arrange for repairs if there is damage or illegible markings.

Power cable

4. 



DANGER!

Electric shock!

Check the power cable and power plug for damage and insufficient fastening. Have them exchanged by PLARAD[®] service if they are damaged.

Never replace them yourself.

Remote control

5.  Check the remote control and the remote control cable for damage and insufficient fastening. Have them exchanged by PLARAD[®] service if they are damaged.

Hydraulic hoses

6.  Check the hydraulic hoses and connections for damage and leaks. Check the period of use. Have the hoses replaced if they are damaged or if the maximum permissible service life has been exceeded.



7. ➔



WARNING!

Danger of injury due to faulty hydraulic power pack!

Do not use the hydraulic power pack if it is faulty. Have it repaired immediately or have the faulty parts exchanged. Contact PLARAD[®] service.

8.3 Changing the oil

- Personnel: ■ User
- Protective equipment: ■ Protective work clothing
 ■ Safety goggles
 ■ Safety gloves
 ■ Safety shoes

The hydraulic oil must be changed yearly or after 150 operating hours.

Operating hours

Draining the oil

Topping up the oil

Oil level



Fig. 19: Sticker for oil level

Cleaning

1. ➔ Read the operating hours on the control system' display.
2. ➔ Put a container with sufficient volume (☞ *Chapter 11 'Technical data' on page 61*) under the hydraulic power pack. Open the oil drain plug.
3. ➔ Close the oil drain plug if the oil has been fully discharged.
4. ➔ Open the cover of the oil filling neck.
5. ➔ Carefully fill clean new hydraulic oil (☞ *'Oil specifications' on page 62*) into the surge tank via a funnel and oil strainer until the correct oil level is reached.
6. ➔ Do not add any more oil if the oil level in the sight glass matches the depiction on the "max Oil" sticker.
7. ➔ Close the cover of the oil filling neck.
8. ➔ Clean the work environment in the proper manner. Dispose of the oil in an environmentally sound manner or reuse it.

8.4 Having service tasks performed by the manufacturer

Service intervals

The service intervals are dependent on the conditions of use and the operating site.

Service interval	Conditions
Every 3 months	<ul style="list-style-type: none"> ■ In the event of extreme operating conditions (e.g. dust, dirt) ■ In the event of high frequency of use, multi-shift operation
Every 6 months	<ul style="list-style-type: none"> ■ In the event of standard operating conditions ■ In the event of average frequency of use
Every 12 months	<ul style="list-style-type: none"> ■ In the event of low frequency of use

Contacting service



WARNING!

Danger of injury due to improperly performed service tasks!

Contact PLARAD[®] service in good time regarding the following service tasks.

Do not perform service tasks yourself.

Service tasks

Personnel: ■ PLARAD[®] service



Perform service tasks as per the manufacturer's specifications.

Component	Service task
Hydraulic power pack	Check for damage. Rectify any damage.
	Change the oil and oil filter.
	Replace wear parts.
	Exchange damaged markings (e.g. seals).
	Test as per DGUV Regulation 3.
	Perform the software update.
	Check the oil-immersed motor and gearbox for damage. Rectify any damage.
Pressure gauge	Perform service as stipulated by the manufacturer.
	Replace the pressure gauge certificate.
Accessories	Check for damage; exchange.
	Exchange damaged markings.



9 Troubleshooting

Error code on the XB32 display



Fig. 20: Example, error code

The error code is stated on the display of the XB32 control system.

9.1 Error messages in the XB32 display



Contact ↗ 'PLARAD[®] service' on page 4 if you have any questions about error messages.

The following messages are displayed:

Display	Meaning
PLARAD XE1... Rev nnn	Start message, control system revision number
1234.5 h	Operating hours
6 A	Current power consumption
57 °C	Oil temperature

Error codes of the XB32 control system:

Display	Meaning	Note
E 27 A	Motor current too high	Disconnect the hydraulic power pack from the power supply. Remedy the cause of the error.
E< 40 Hz	Mains frequency too low (measurement no longer possible below 40 Hz)	If the mains frequency is back within the permissible range (mains frequency \pm 5 Hz), the error condition does not apply and work can continue.
E 45 Hz	Mains frequency too low	
E 78 Hz	Mains frequency too high	
E> 80 Hz	Mains frequency too high (measurement no longer possible above 80 Hz)	
E 92 °C	Winding temperature too high	If the temperature drops below 80 °C, the error condition does not apply and work can continue.

Display	Meaning	Note
E43 0001	Temperature sensor short circuit	Disconnect the hydraulic power pack from the power supply. Remedy the cause of the error.
E43 0002	Temperature sensor cable break	
E81 xxxx	Error during hardware initialisation	Disconnect the hydraulic power pack from the power supply. Wait 1 minute. Reconnect. If the error occurs again, contact PLARAD [®] service.
E82 xxxx	Error during software initialisation	
EFF xxxx	Internal error	
∅V	Supply voltage drops	The message appears briefly when switching off. Disconnect the hydraulic power pack from the power supply.

“xxxx”: Advanced error codes that contain details of the error for PLARAD[®] service.

9.2 Performing troubleshooting

Improperly performed troubleshooting



WARNING!

Danger of injury due to improperly performed troubleshooting!

Improper troubleshooting can cause serious injuries and significant property damage.

- Have all repairs performed by the manufacturer.
- Never open components of the hydraulic power pack.
- Use only PLARAD[®] original parts.

Device damage

- ➔ Contact  ‘PLARAD[®] service’ on page 4 if there is any damage to the hydraulic power pack.

Power supply

1. ➔ Check the power cable and connections and arrange for exchange if there is damage.
2. ➔ Check the electrical parameters and correct the power supply.



Returning to service after remedying the error



WARNING!

Danger of injury due to faulty hydraulic power pack!

If a hydraulic power pack is not properly repaired, this can cause serious injuries.

- Never return a defective hydraulic power pack to service.

→ Prior to first use, have a test performed as per DGUV Regulation 3.

10 Disposal

The hydraulic power pack must be disposed of in an environmentally sound manner at the end of its service life.

Disassembly



WARNING!

Danger of injury due to short circuit and stored residual energy!

If components are damaged, there is a danger of injury due to short circuit or the continued presence of stored residual energy.

1. ➤ Disconnect the hydraulic power pack from the power supply. To do so, unplug the power plug.
2. ➤ Remove the hydraulic hoses.
⇒ Reuse these components if necessary.
3. ➤ Put a container with sufficient volume (☞ *Chapter 11 'Technical data' on page 61*) under the hydraulic power pack. Open the oil drain plug.
4. ➤ Close the oil drain plug if the oil has been fully discharged. Clean the work environment in the proper manner. Dispose of the oil in an environmentally sound manner or reuse it.
5. ➤ Do not dismantle the hydraulic power pack any further.

Draining the oil

Disposal

If no take-back or disposal agreement has been put in place, dispose of the hydraulic power pack as electronic waste in accordance with local regulations. Use authorised collection points for the reprocessing of old electrical and electronic devices.

Dispose of waste oil in an environmentally sound manner as per local regulations.



ENVIRONMENT!

Danger to the environment due to incorrect disposal!

Incorrect disposal can be hazardous to the environment.



Do not allow electronic components to enter bodies of water, the sewage system, the soil or household waste collection.

Have electronic waste, electronic components, lubricants and other auxiliary materials disposed of by approved specialist companies.

If in doubt, obtain information about environmentally sound disposal from the local municipal authority or from specialist disposal companies.



11 Technical data

Dimensions and weight

Dimensions and weight are dependent on the hydraulic power pack version. See the technical data sheet regarding specific values for the hydraulic power pack.

Data	Value	Unit
Weight*	20 – 42	kg
Length	455 – 500	mm
Width	246 – 343	mm
Height	381 – 465	mm

* See the rating plate for specific details.

Performance values

Data	Value	Unit
Pressure, maximum*	350 – 2400	bar
Flow rate	0.8 – 13.2	l/min
Drive power	0.8 – 2.2	kW

* See the rating plate for specific details.

Electrical connected loads

Specific details on the rating plate:

- Mains voltage
- Mains frequency
- Nominal current
- Protection class

Possible electrical connected loads:

- Alternating current:
AC 100 V, AC 110 V, 220 V, 230 V – 50/60 Hz
- Three-phase alternating current:
3 AC 200 V, 3 AC 400 V, 3 AC 440 V, 3 AC 480 V – 50/60 Hz

Minimum connected load for mobile power generators: 4 kVA

Environment

Data	Value	Unit
Temperature range	-10 – 50	°C
Relative humidity, maximum	Non-con- densing	

Emissions

Emission levels as per EN 60745

Data	Value	Unit
Emission sound pressure level	89	dB(A)

Data	Value	Unit
Measurement uncertainty of emission sound pressure level	3	dB(A)

Oil specifications

Data	Value	Unit
Usable oil volume with surge tank (standard) for:		
Motor size 1	0.1	l
Motor size 2 and 3.5	0.3	l
Additionally usable oil volume with auxiliary tank (option)	4	l
Filter insert	10	µm
Hydraulic oil	Shell Tellus S2 VX 15	

12 Index

A

Accessories	18
Adjustment lock	15
Attachment points	9
Authorised partners	4

B

Brief description	12
-------------------------	----

C

Cleaning	54
Connected loads	61
Connection	17
Controls	14
Copyright	3
Customer service	4, 35

D

Delivery	7
Checking	7
Packaging material	8
Scope	7
Disassembly	60
Displays	14
Disposal	60

E

Electrical current	25
Electronic waste	60
Emissions	61
Environmental protection	37
Electrical and electronic components	37
Hydraulic oil	37
Lubricants	37
Error	57
Messages	57
Performing	58
Error messages	57

F

Faults	57
--------------	----

Follow-up order	4
-----------------------	---

G

Gear pump	14
-----------------	----

H

Help	35
Hydraulic oil	62
Hydraulic power pack	
Getting to know	11

I

Installation site	38
Intended use	23

L

Loosening	51
-----------------	----

M

Maintenance	52
Changing the oil	55
Cleaning	54
Manufacturer	56
Oil level	54, 55
Overview	52
User	54
Maintenance schedule	52
Manual	
Loosening	51
Tightening	50
Manufacturer	4
Maschinenfabrik Wagner	4
Misuse	24
Monitoring	
Mains voltage and frequency	31
Motor current	32
Motor oil temperature	32
Pressure	32

N

Noise emissions	61
-----------------------	----

O		Electrical energy	25
Oil change	55	Hot surfaces	30
Oil specifications	62	Mobile power generator	26, 41
Old devices	60	Moving components	29
Operating conditions	61	Noise	30
Operating mode	15	Power plug	26, 41
Operator	35	Rotational movements	29
Operator's obligations	33	Thermal overload	26, 41
Ordering spare parts	53	UV radiation	26, 41
Other applicable documents	3	Weight	29
Overview	11		
P		S	
Packaging material	8	Safety	19
Performance values	61	Safety devices	31
Personal protective equipment	35	Service	4, 35
Personnel	34	Service tasks	56
Personnel qualifications	34	Signs	21
PLARAD customer service	35	Stages	15
PLARAD service	35	Starting	44
Power plug	17	Stickers	21
PPE	35	Suggestion for improvement	3
Preparation	43	Symbols	
Pressure adjustment valve	15	In the manual	19
Pressure displays	15	on the hydraulic power pack	21
Pressure gauge	15	T	
Process connection	17	Technical data	61
Protection class II	22	Tightening	50
Q		Transport	7
Qualified hydraulic power pack personnel	34	Crane	9
Quick-release coupling	17	Forwarding agent	8
R		Industrial truck	9
Rating plate	13	U	
Remote control	16	Unauthorised persons	35
Residual risks	24	Unpacking	7
Bracing	29	User	34
Cable	26, 41	User requirements	34
Crushing	29	V	
Ejection	29	Versions	13
Electric shock	25		



W

Who can I ask? 35

Appendix



In addition to this manual, the following documents are supplied in a document folder enclosed with the hydraulic power pack.

- EU declaration of conformity
- CD-ROM
- Test report for testing electrical equipment as per DIN VDE 0701-0702
Testing of equipment as per DGUV Regulation 3
- Certificates (option)