

Electric Power Pack



IQ-VAX - Z

XB-VAX - Z

V50 series

Operating manual

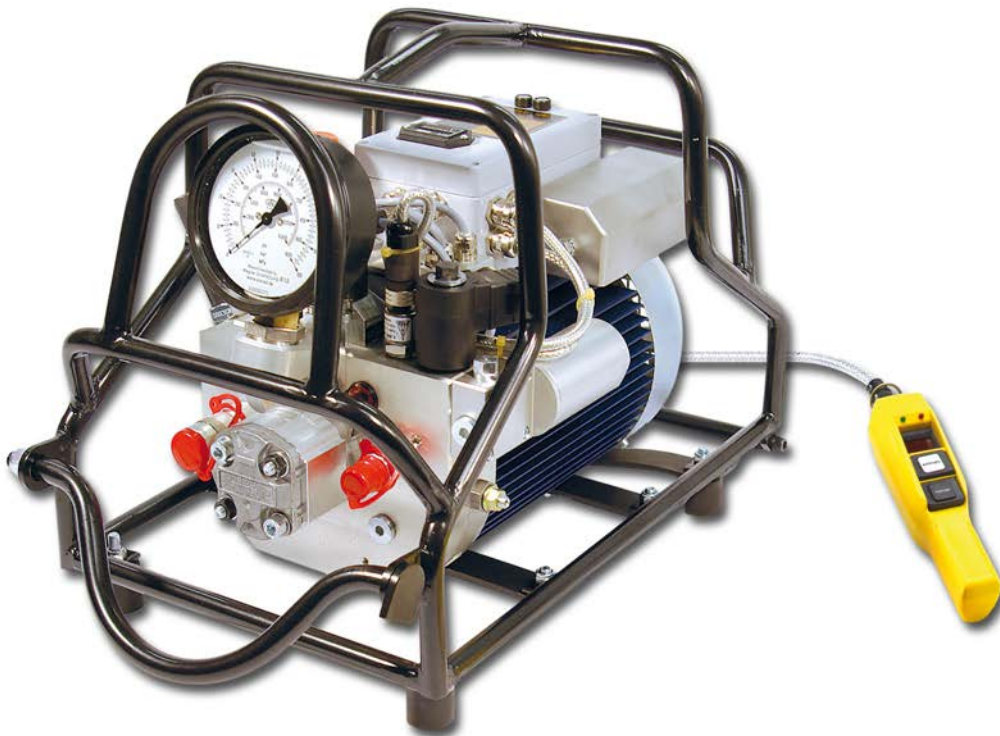

Contents

- 1. Manufacturer 3**
- 2. Notes 3**
 - 2.1. CE Mark 3
 - 2.2. Directives 3
 - 2.3. Notes Concerning the Operating Instructions 3
 - 2.4. Notes Concerning the Workplace 3
 - 2.5. Basic Safety Notes for Use of Transportable Electric Equipment 3
 - 2.6. Basic Safety Notes for Use of Hydraulic Power Packs 4
 - 2.7. Product Identification 5
 - 2.8. Symbols and Warnings 5
- 3. Product Information 6**
 - 3.1. Intended Use 6
 - 3.2. Improper Use 6
 - 3.3. Applicable Additional Operating Instructions 6
- 4. Scope of Delivery 6**
- 5. Technical Data 6**
- 6. Transport 7**
- 7. Preparing for Operation 7**
 - 7.1. Safety Notes for Operation 7
 - 7.2. Filling and Starting the Hydraulic Power Pack 7
 - 7.3. Preparing the Bolting Process in Calibration Mode 9
 - 7.4. Deleting the Calibration Values 9
- 8. Operation 10**
 - 8.1. Automatic Bolting 10
 - 8.2. Manual Bolting 10
 - 8.3. Safety Function 10
- 9. Maintenance 10**
- 10. Error Messages 10**
 - 10.1. Errors Indicated by the Checklights 10
- 11. Instructions for Disposal 12**

1. MANUFACTURER

Maschinenfabrik Wagner GmbH & Co. KG
53804 Birrenbachshöhe, Much
+49 (02245) 62-0

2. NOTES

2.1. CE Mark

The products bear the CE Marking. The declaration of conformity certifies that the products meet the safety requirements set forth in the directives of the European Union.

2.2. Directives

The product meets the requirements of the EU Machinery Directive 2006/42/EC.

2.3. Notes Concerning the Operating Instructions

These operating instructions contain important notes concerning operation, operating site and connection of the unit. Be sure to read these notes carefully before operating the unit.

This will help protect you and will provide access to important information concerning proper connection, use and safety of the unit.

The operating instructions are part of the unit. Keep them readily available near the unit. Proper adherence to the operating instructions is a precondition for intended use and proper operation. When selling the unit, be sure to pass the operating instructions on to the new owner.

Please note that the product supplied may differ in some details from the illustrations and the technical data presented in these operating instructions.

The information presented in these operating instructions corresponds to the status at the date of printing. We reserve the right to make amendments at any time without prior notice.

2.4. Notes Concerning the Workplace

We recommend a one-man-only type of operation of the hydraulic nutsetter. Only one trained and authorised person may control the operation of the tool. Perform a risk evaluation before allowing two persons to operate the unit. If two persons operate the unit, ensure that the application, the communication and the coordination of the tool have been discussed and agreed upon between the users beforehand. The person positioning the hydraulic nutsetter should issue the commands for operation of the hydraulic power pack, even if he does not operate the remote control.

Safety of the operator and trouble-free operation are guaranteed only if original PLARAD components are employed. This is especially true of unit parts and spare parts.

If other components are used, Maschinenfabrik Wagner cannot accept any liability for safe operation and reliable function.

2.5. Basic Safety Notes for Use of Transportable Electric Equipment

ATTENTION! To prevent electric shock, injury or fire, observe the following basic safety notes when using electric appliances.

Read all of these notes before using the unit, permanently save these safety notes.

Work safely

1. Keep your workplace neat
 - Disorder at the workplace may lead to accidents.
2. Consider the ambient conditions
 - Do not allow the unit to get wet in the rain.
 - Do not use the unit in moist or wet environments.
 - Ensure proper lighting of the workplace.
 - Do not use the unit if there is a fire or explosion hazard.
3. Protect yourself from electric shock
 - Avoid body contact with earthed parts.
4. Keep other persons away
 - Do not allow other persons, especially not children, to touch the unit or the cable. Keep other persons away from the workplace.
5. Store unused units in a safe place
 - Unused units should be saved in a dry, elevated or locked place, outside the reach of children.
6. Do not overload the unit
 - Work is easier and safer when the unit is used within its specified performance range.
7. Use the correct unit
 - Do not use a weak unit for heavy-duty work.
 - Do not use the unit for jobs it was not meant to do.
8. Wear suitable clothing
 - Do not wear loose fitting clothes or jewellery; it might get caught by moving parts.
 - When working outdoors it is wise to wear slip-resistant shoes.
 - Wear a hair net for long hair.
9. Use personal protective equipment
 - Wear safety glasses when the work entails a risk of eye injury.
10. Do not use the cable for purposes it is not meant for.
 - Do not use the cable to pull the plug from the power socket.
 - Protect the cable from heat, oil or sharp edges.
11. Avoid an abnormal posture
 - Ensure safe standing and be sure to hold your balance at any time.
12. Maintain your units with care

- Regularly check the connecting cable of the unit and have it replaced by a recognised specialist if it is damaged.
 - Regularly check extension cables and replace them if they are damaged.
 - Keep handles dry, clean and free from oil or grease.
13. Pull the plug from the power socket
- When the unit is not used, prior to maintenance or replacement of tools, disconnect the unit from power.
14. Use extension cables suitable for outdoor use
- Outdoors use only extension cables which are specifically approved for outdoor use and are marked to this effect.
15. Be attentive
- Take care what you do. Work reasonably. Do not use the unit if you have difficulty concentrating.
16. Check the unit for damage
- Before use check the guards or slightly damaged parts for proper function as intended.
 - Check that moving parts function properly and do not jam or are damaged. All parts must be fastened properly and meet all conditions for proper operation of the unit.
 - Damaged guards and parts must be repaired or replaced by a recognised specialised workshop, unless the operating instructions allow a different procedure.
 - Damaged switches must be replaced by a customer service workshop.
 - Do not use units when the power switch cannot be switched on and off.

Maintenance, care, repair

Before adjusting, maintaining or repairing the unit pull the plug.

Have your unit repaired by a workshop for electric appliances

- This electric unit conforms to the applicable safety rules. Repairs must be performed exclusively by an electrician, who must use original spares; otherwise accidents injuring the user may result.

2.6. Basic Safety Notes for Use of Hydraulic Power Packs

When operating the unit, be sure to observe locally applicable laws and regulations.

Before operating the unit, check that it is functioning safely and is in proper condition. The operator must be familiar with the operation of the unit. Before taking the unit into service, check the unit and the hose(s) for damages. Immediately replace damaged hoses, couplings and nipples.

Only connect/disconnect units when the hydraulic power pack is switched off. If this is not observed, the unit may be damaged and pressurised medium may escape. This in turn may lead to eye injury and burns. Concerning contact with consumables observe the material safety data sheets and the product information for the consumables.

If an extension cable with lower conductor cross-section and substantial length is used, voltage drop may occur, negatively affecting motor start-up. Exclusively use extension cables meeting the following requirements:

Line voltage	Minimum conductor cross-section
230 V	1.5 mm ²
100/110 V	2.5 mm ²

Outdoors use only extension cables, which are specifically approved for outdoor use and are marked to this effect.

2.7. Product Identification

The power pack is identified by the nameplate on the cover of the controller housing.



2.8. Symbols and Warnings



CE Mark



Observe assembly and operating instructions



Wear hearing protectors



Wear eye protection



Warning of hazards. The type of hazard is indicated by the text next to the symbol



Warning of hazardous electric voltage



Warning of hot surface

10	1	2	3	4	5
11	next maintenance				6
12	nächste Überprüfung				7
13	12	11	10	9	8

Service tag with note concerning next check-up



WEEE recycling and disposal instruction. This product must not be disposed of with household wastes.

3. PRODUCT INFORMATION

3.1. Intended Use

The Plarad hydraulic power pack is a portable hydraulic energy generator meant to drive hydraulic nutsetters. It is meant exclusively for professional use in conjunction with Plarad hydraulic nutsetters.

The bolting process is controlled automatically and stopped automatically as soon as the set pressure is reached.

Two hydraulic nutsetters may be connected to the hydraulic power pack at the same time (twin-mode).

The nutsetter is suitable for indoor and outdoor operation at ambient temperatures of -20 to +70 °C. If these values cannot be adhered to, contact the manufacturer before starting operation.

The hydraulic power pack may be operated on permanent local mains or a mobile power generator, provided the connecting values specified in the technical data are met.

Have assembly, readjustment, changes, extensions and repairs of the unit performed exclusively by Maschinenfabrik Wagner or service partners authorised by Maschinenfabrik Wagner. Exclusively use the unit as described in these operating instructions. This only will allow safe, reliable operation. Unauthorised alterations may cause unexpected hazard.

Safety of the operator and trouble-free operation are guaranteed only if original PLARAD components are employed. This is especially true of unit parts and spare parts.

If other components are used, Maschinenfabrik Wagner cannot accept any liability for safe operation and reliable function.

3.2. Improper Use

Any other use or use beyond these conditions is considered unintended. The risk lies solely with the owner/operator.

3.3. Applicable Additional Operating Instructions

- BGR/GUV-R 194 Use of hearing protection
- BGR 237, Rules for safe application of hydraulic hoses
- Shell Tellus S2 V 15, PD / MSDS

4. SCOPE OF DELIVERY

- Hydraulic power pack, filled with oil and ready to operate

Consumables (re-order if needed)

- Filter insert 10 µm
K20-058-4-27901
- Hydraulic oil 1 l Shell Tellus S2 V 15 K20-001-4-16402
- Hydraulic oil 5 l Shell Tellus S2 V 15 K20-001-4-16404

5. TECHNICAL DATA

Maximum operating pressure: 800 bar

Minimum connected load for mobile generators 4 kVA

IQ VAX 1 Z

L x W x H (mm)	460 x 350 x 330
Flow rate	5.3 l/min at 10 ... 70 bar 0.75 l/min at >70 ... 800 bar
Power supply	See nameplate
Weight	22 kg
Sound pressure level (800 bar)	82.4 dB (A)* 1 m

IQ VAX 2 Z

L x W x H (mm)	500 x 350 x 350
Flow rate	8.0 l/min at 10 ... 70 bar 1.2 l/min at >70 ... 800 bar
Power supply	See nameplate
Weight	29 kg
Sound pressure level (800 bar)	83.74 dB (A)* 1 m

IQ VAX 3.5 Z

L x W x H (mm)	520 x 350 x 330
Flow rate	13.0 l/min at 10 ... 70 bar 3.0 l/min at >70 ... 800 bar
Power supply	See nameplate
Weight	36 kg
Sound pressure level (800 bar)	89.2 dB (A)* 1 m

* During operation of the power pack, the sound pressure level decreases by 6 dB(A) per metre distance to the power pack.

Note concerning application temperatures

When operating the unit at temperatures below -5 °C, start the power pack (several times if required) until the motor runs. Set the pressure limiting valve to 400 bar. Do not connect a hose or nutsetter to the power pack and let it run for approx. 5 minutes while keeping the "manuell" button pressed..

6. TRANSPORT

When transporting the hydraulic power pack using a crane or similar lifting equipment, attach the unit at the points marked in the picture below.

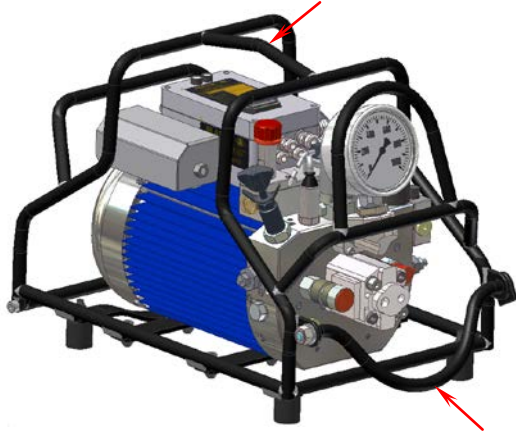

7. PREPARING FOR OPERATION

The hydraulic power pack generates hydraulic pressure, which is set at the pressure-limiting valve and read off at the pressure gauge. High-pressure hoses (supply and return) supply the pressurised medium to the nutsetter. The nutsetter converts the pressure into a torque by means of a lever and ratchet system.

This section contains a brief description of all control elements and connections. The operating procedures described must be followed to ensure safe use of the hydraulic power pack.

7.1. Safety Notes for Operation



Caution

Noise emission at approx. 85 dB(A).

- **Wear hearing protectors to EN 458 if the distance between the operators and the hydraulic power pack is lower than 2 m (BGR/GUV – R 194).**



Warning!

At high ambient temperature and after longer operating time the hydraulic power pack may reach surface temperatures of up to 80 °C.

- **Wear heat resistant gloves! Allow the hydraulic power pack to cool down before transporting it.**



Warning!

An unsafely positioned hydraulic power pack may tip over or fall from a height.

- **Be sure the hydraulic power pack rests on a solid, level base with all of its four feet!**



Warning!

Hot hydraulic fluid may escape at high pressure and cause severe burns and cuts.

- **Before starting to operate the unit, check it for tightness. If leaks are detected, stop operating the unit and have it repaired before further use.**

7.2. Filling and Starting the Hydraulic Power Pack

1. Check the oil level. Be sure the hydraulic power pack stands horizontally, to be able to read the correct value.

The oil level is okay, when the oil level sight glass is filled up to the centre.

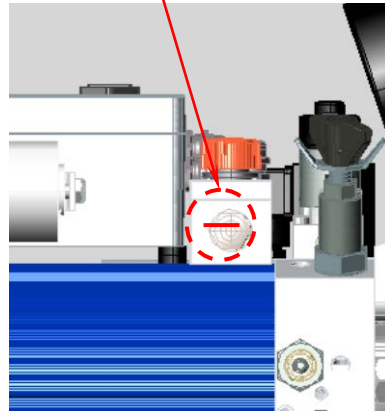

2. If the oil level is not okay, top up hydraulic oil at the filler neck until the oil level sight glass is filled up to the centre.

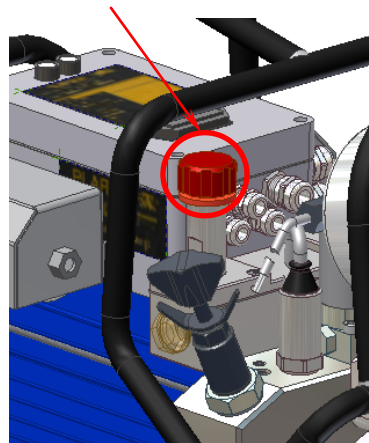

3. Compare the power supply data on the nameplate to the supply on site or to the output data of the mobile generator used. Connect the unit only if the information agrees.
4. Check the power supply cable for damages and connect it only if it is undamaged.
5. Connect the plug to the power supply.

The hydraulic power pack starts a self-test. All 4 checklights light up for approx. 5 seconds. (The self-test may be interrupted by pressing a button).

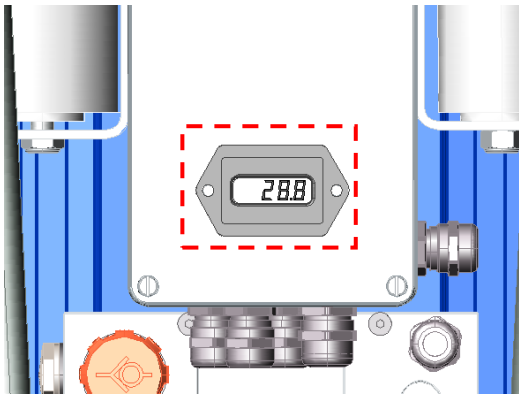

After the self-test the display shows the operating hour counter.

6. Connect the hydraulic hoses to the hydraulic power pack.

The pressure port on the hydraulic power pack is fitted with a coupling. (This applies when the CEJN series 115 is used, individual power packs may be furnished differently.)

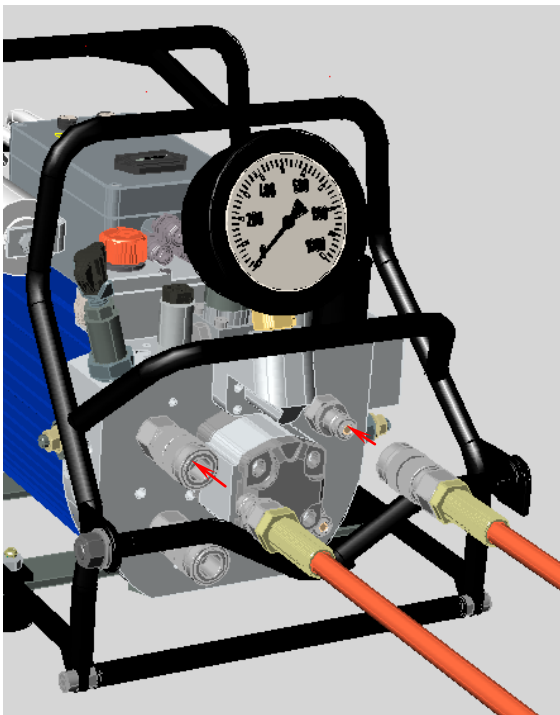

7. Do *not* yet connect the hydraulic nutsetter.

8. Connect the hydraulic hoses to one another at the other end. If you are operating the unit in twin-mode, connect both hose pairs to one another.

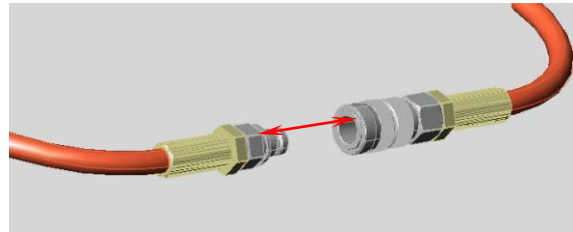

9. Switch on the hydraulic power pack with the “manuell” button.
10. Press the “manuell” button for approx. 30 seconds.
The hydraulic hoses are thereby de-aired.



11. Switch off the hydraulic power pack with the “off” button.



12. Connect the hydraulic nutsetter to the hydraulic hoses.
The hydraulic power pack is now ready to be calibrated with the values for automatic bolting.

7.3. Preparing the Bolting Process in Calibration Mode

In the calibration mode the hydraulic power pack performs measurements. The hydraulic power pack uses the measured values for automatic control of the bolting process.



Important!
During the calibration mode, the hydraulic nutsetter must not be applied to the fastening location.

Before start of the calibration mode, the green checklight on the remote control lights up. As long as it flashes slowly, calibration is still in progress. Proceed as follows:

1. Select the sense of rotation.

When the green checklight flashes, tightening is selected.

When the red checklight flashes, loosening is selected.

Calibration can be made in tightening or loosening mode. To switch modes press the “automatic” button on the remote control.



2. Switch on the hydraulic power pack with the “manuell” button.
The checklight now flashes faster, thus indicating that the start process is running.
The start process is complete when the checklight flashes slowly again. Wait until this happens, before taking the next step.

3. Press and hold the “manuell” button on the remote control. At the pressure adjusting valve, set the required hydraulic pressure. Then let go of the “manuell” button.

Read the set pressure at the pressure gauge or on the remote control (if your remote control features a digital display).

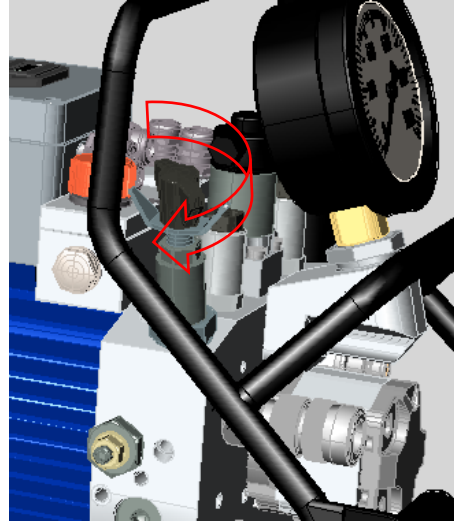

4. Read the required pressure from the torque table for the hydraulic nutsetter.
5. Press and hold the “automatic” button.

Automatic calibration begins. During the measurement, the hydraulic nutsetter performs several operating cycles.

The hydraulic power pack uses the measured values for automatic control of the bolting process. The measured values apply only to the components currently connected.

As soon as calibration is complete, the checklight on the remote control does no longer flash, but is continuously on.

When both checklights flash at the end of calibration, an error has occurred, see 10 Error Messages.

7.4. Deleting the Calibration Values

The calibration values can be deleted. This is required after other components have been connected. Proceed as follows:

1. Press and hold the “off” button. Additionally press and hold the “automatic” button.
As soon as the calibration values have been deleted, the checklight switches from continuous light to flashing.
2. The calibration values are also deleted when you disconnect the hydraulic power pack from the power supply.

8. OPERATION

8.1. Automatic Bolting

1. Attach the hydraulic nutsetter to the fastening location (for details refer to the operating instructions of the hydraulic nutsetter).
2. Press and hold the “automatic” button.
Automatic bolting begins. The checklight flashes rapidly.
As soon as the bolting process is complete, the checklight switches over to continuous light.



Important!

If the checklight flashes slowly, a calibration error has occurred. See 10 Error Messages. If error messages are displayed, check the pressure of the hydraulic power pack and repeat the calibration.

8.2. Manual Bolting

For manual bolting the hydraulic power pack does not need to be calibrated first. Proceed as follows:

1. Read the required pressure from the torque table for the hydraulic nutsetter.
2. Set the pressure at the pressure adjusting valve.
3. Press and hold the “manuell” button.
The nutsetter turns in tightening direction. The checklight flashes rapidly.
4. Keep the “manuell” button pressed until the nutsetter stops turning. Let go of the “manuell” button.
The nutsetter reverses.
Wait until the checklight flashes slowly.
5. Again press and hold the “manuell” button until the nutsetter stops turning.
6. Alternately press and let go of the “manuell” button until the nutsetter does no longer turn when you press the button and the set pressure has been reached.



Important!

After shut-down of the hydraulic power pack the hydraulic hoses are still pressurised. Press the black cap at the directional valve to relief the hydraulic hoses. Thereafter you may disconnect the hydraulic hoses from the hydraulic power pack.

8.3. Safety Function

If the values reached during bolting differ from those calibrated, the controller indicates this by alternate flashing of the red and green checklight.
Confirm the error message by pressing the “automatic” button. All functions of the remote control are locked

until you have acknowledged the error message (except for “off”).

9. MAINTENANCE



Warning!

Hazardous electric voltage. Unexpected start-up by unintentional activation.

- **Before adjusting, maintaining or repairing the unit, pull the plug.**

Note the following points:

- Regularly check the oil level of the hydraulic power pack; be sure to check it every time before starting operation.
- Replace the oil after 150 operating hours, latest after one year.
- Keep the couplings and nipples of the hydraulic power pack, the hydraulic hoses and the hydraulic nutsetter clean. Clean the couplings and nipples with a cloth before connecting hoses.
- For transport, protect the couplings and nipples with caps.

10. ERROR MESSAGES

When an error message occurs, the controller prevents further operation. Confirm the error message by pressing the “automatic” button. The controller releases further operation.

- The pressure set at the pressure adjusting valve corresponds to the required torque (as specified in the torque table for the nutsetter). The pressure reached at shut-off of the hydraulic power pack is decisive for achieving the correct tightening torque for the joint.
- Set the required pressure in the calibration mode. To reach this pressure (torque) during each bolting process, the controller monitors the actual pressure during the bolting process. If the pressure has been misadjusted unintentionally, this leads to a faulty torque being applied. If the pressure reached is not within a tolerance of ±10 bar of the calibrated pressure, the bolting is evaluated NOT OKAY (NOK). The controller indicates this by alternately flashing the red and green checklights of the remote control.
- If pressure cannot be build up anymore, although the calibrated pressure has not been reached yet, the hydraulic power pack switches off after 2 seconds.
- If the actual pressure exceeds the set pressure, the controller terminates the bolting process at an actual value exceeding the calibrated pressure by 10 bar. This immediate shut-off prevents overtightening of the joint.

10.1. Errors Indicated by the Checklights

The hydraulic power pack has four checklights: two on the cover of the controller housing and two on the remote control.

The checklights on the cover of the controller housing indicate malfunctions of the hydraulic power pack. The checklights on the remote control indicate the status of the bolting process. The messages are given by different flashing frequencies.

Checklights on the controller housing

Checklight 1 Checklight 2

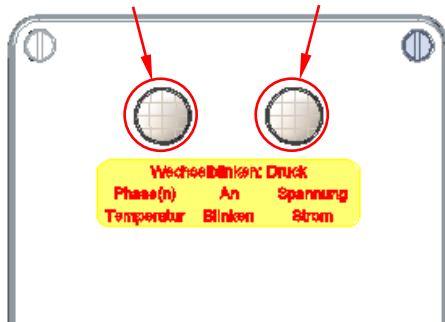

Checklights on the remote control

Green checklight Red checklight



Flashing frequency	Cause
Checklight 1 continuously on	On three-phase current units: Sense of rotation is faulty. General: Voltage wrong, sense of rotation detection failing.
Checklight 1 flashes	The maximum admissible temperature of the power pack is exceeded.
Checklight 2 continuously on	The supply voltage is outside the admissible range.
Checklight 2 flashes	The maximum admissible current consumption of the power pack is exceeded.
Checklights 1 and 2 flash alternately	The admissible maximum pressure of the power pack is exceeded. <i>Separate the power pack from the power supply and check the pressure adjusting valve – admissible maximum pressure 820 bar. Re-connect the power pack to the power supply and re-start it.</i>

The green checklight lights up during tightening of a joint.

The red checklight lights up during loosening of a joint.

The messages are given by varying flashing frequencies.

Flashing frequency	Function
Green checklight flashes slowly	The bolting system is operating in "tightening" mode. Upon start of the bolting system, as long as calibration has not yet been performed.
Green checklight flashes rapidly	The bolting system is operating in "tightening" mode. Fast flashing always indicates that a process is running, e. g. start of the power pack or tightening process is running.
Green checklight continuously on	The bolting system is operating in "tightening" mode. Function 1: Upon successful calibration. Function 2: Upon successful bolting.
Red checklight flashes slowly	The bolting system is operating in "loosening" mode. Upon start of the bolting system, as long as calibration has not yet been performed.
Red checklight flashes rapidly	The bolting system is operating in "loosening" mode. Fast flashing always indicates that a process is running, e. g. start of the power pack or loosening process is running.
Red checklight continuously on	The bolting system is operating in "loosening" mode. Upon successful loosening.
Red and green checklight alternately flash rapidly	An error has occurred. Also refer to "Checklights on the controller housing".
Red and green checklight alternately flash slowly	An error has occurred. Also refer to "Checklights on the controller housing".

11. INSTRUCTIONS FOR DISPOSAL

Dispose of the hydraulic power pack according to the locally applicable regulations.



Attention!

This symbol alerts to the fact that the product may not be disposed with domestic wastes as required by the WEEE directive (directive for waste electrical and electronic equipment, 2002/96/EC) and national laws.

- **This product must be turned over for recycling at the prescribed collection location. This can be done by returning the product upon purchase of a similar product or by turning it over to an authorised body for collection and recycling of waste electrical and electronic equipment.**
- **Information concerning collection locations for waste equipment is available from town authorities, public waste disposal organisations, or an authorised body for disposal of waste electrical and electronic equipment or the local waste removal company.**



... a successful
connection!

Maschinenfabrik Wagner GmbH & Co. KG
Birrenbachshöhe · 53804 Much · Germany

Tel. national: (02245) 62-0
Fax national: (02245) 62-66
Phone international: +49 (0)2245 62-10
Fax international: +49 (0)2245 62-22

info@plarad.com · www.plarad.com

Reproduction and copying of this volume, in whole or in part, is permissible only with express written permission. Subject to amendment. We take no responsibility for printing errors or inaccurate information.
Last update: 11/2020

69807

2_BA_IQ-VAX-Z+XB-VAX_V50_GBR_2.0_69807