

Operating instructions

Manual torque amplifier
XVK/XVR/XVR-D 45



PLARAD[®] 
Torque & Tension Systems

Read the manual carefully before use!
Keep for future use.

Maschinenfabrik Wagner GmbH & Co. KG

Birrenbachshöhe 12

53804 Much

GERMANY

Telephone: +49 2245 62-0

Fax: +49 2245 62-22

Email: info@plarad.de

Internet: www.plarad.de

Translation of the original operating instructions

pA# 69431, 1, en_GB



Information about this manual



This manual enables safe and efficient handling of the manual torque amplifiers XVK and XVR (referred to in the following as “torque amplifiers”).

The manual is a component of the torque amplifier and must be kept in its immediate vicinity so that the user can access it at any time.

The user must have read and understood this manual prior to commencing any tasks. A basic prerequisite for ensuring that work is performed safely is compliance with all safety instructions and guidelines in this manual. In addition, the local accident prevention regulations and general safety provisions for the torque amplifier’s area of application apply.

Illustrations in this manual serve to provide a basic understanding and may differ from the actual design.

Versions

This manual applies to the following torque amplifiers:

Torque amplifier type XVK	Torque amplifier type XVR
XVK 15	XVR 25
	XVR 35
	XVR 40
	XVR 65
	XVR 70
	XVR 90
	XVR-D 45

Other applicable documents



The following documents must be observed in addition to this manual:

- Rating plate
- EU declaration of conformity
- Torque chart
Individual correlation of input torques to output torques
- Technical data sheet for torque amplifier
- Calibration certificates (optional)
- Technical data sheet for torque wrench (if applicable)

Copyright

This manual is protected by copyright.

The transfer of this manual to third parties, duplications of any kind and form – including excerpts – as well as the utilisation and/or communication of the manual's contents are not permitted without the written consent of Maschinenfabrik Wagner GmbH & Co. KG, except for internal purposes. Infringements will result in liability for damages. Maschinenfabrik Wagner GmbH & Co. KG reserves the right to assert additional claims.

Maschinenfabrik Wagner GmbH & Co. KG is the copyright holder.

Further development of the manual

This manual was compiled with great care. If you notice any errors, have any questions or identify any inconsistencies, please notify us in writing. Your suggestions for improvement will help us design a user-friendly manual.

Manufacturer

Maschinenfabrik Wagner GmbH & Co. KG

Birrenbachshöhe 12

53804 Much

GERMANY

Telephone: +49 2245 62-0

Fax: +49 2245 62-22

Email: info@plarad.de

Internet: www.plarad.de

PLARAD[®] service

Information about PLARAD[®] service and authorised PLARAD[®] partners:

- www.plarad.de



Table of contents

1	Unpacking.....	6
2	Getting to know the torque amplifier.....	8
2.1	Illustration	8
2.2	Controls and function elements.....	10
2.3	Rating plate.....	12
2.4	Accessories.....	12
3	Accessory instructions: torque wrench PH Z.....	13
3.1	Illustration.....	13
3.2	Intended use.....	14
3.3	Using the torque wrench.....	14
3.4	Torque wrench maintenance.....	15
3.5	Disposing of the torque wrench.....	16
4	Before you begin – safety.....	17
4.1	Symbols in this manual.....	17
4.2	Symbols on the torque amplifier.....	19
4.3	Intended use.....	21
4.4	Misuse.....	21
4.5	Residual risks.....	21
4.5.1	Mechanical dangers.....	22
4.5.2	Ergonomics.....	24
4.6	Notes on use.....	24
4.7	Operator's obligations.....	26
4.8	Who is permitted to use the torque amplifier?.....	27
4.9	Personal protective equipment.....	28
4.10	Environmental protection.....	29
5	Using the torque amplifier.....	31
5.1	Determining the particulars of the fastening operation.....	32
5.2	Safe bracing.....	33
5.3	Tightening.....	34
6	Performing maintenance.....	37
6.1	Maintenance schedule.....	37
6.2	Relubricating the gearbox.....	38
6.3	Replacing the shear pin.....	38
7	Disposing of the torque amplifier.....	40
8	Technical data.....	41
9	Index.....	42
	Appendix.....	45

1 Unpacking

Delivery

The torque amplifier is supplied in a metal transport case.

Checking the delivery



Check the delivery for transport damage and ensure it is complete immediately upon receipt. If it is incomplete or if there are defects, note the extent of the damage on the transport documents and lodge a complaint immediately.

Scope of delivery

The scope of delivery includes:

- Transport case
- Torque amplifier
- Reaction arm
- Drive square adapter with O-ring circlip and shear pin
- Circlip pliers
- Ratchet
- Document folder
 - Leaflet with QR access code for operating instructions
 - Torque chart
 - Calibration certificate (optional)



Operating instructions and EU declaration of conformity available at: <https://www.plarad-manuals.com>



Technical data sheet is available online at: <https://www.plarad.de/download-center.html>

**Handling packaging material**

The individual packages are packed according to the expected transport conditions. Only environmentally friendly materials are used for the packaging.

The packaging should provide protection against transport damage, corrosion and other damage. For this reason, do not destroy the packaging and do not remove it until shortly before use.

Dispose of packaging material in accordance with the applicable statutory provisions and local regulations.

**ENVIRONMENT!****Danger to the environment due to incorrect disposal!**

Packaging materials are valuable raw materials and, in many cases, can be further utilised or appropriately reconditioned and recycled. Incorrect disposal of packaging materials can be hazardous to the environment.

- Dispose of packaging materials in an environmentally sound manner.
- Observe the locally applicable disposal regulations. If necessary, engage the services of a specialist company with regard to disposal.

Transport and storage

Transport the torque amplifier only in the transport case and do not take it out of the transport case until shortly before use.

2 Getting to know the torque amplifier

2.1 Illustration

Type XVK

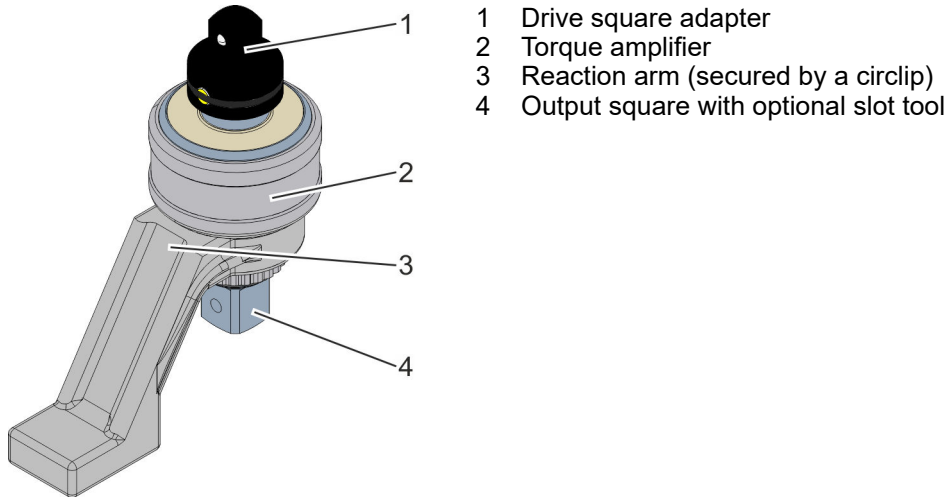

- 1 Drive square adapter
- 2 Torque amplifier
- 3 Reaction arm (secured by a circlip)
- 4 Output square with optional slot tool

Fig. 1: Illustration of torque amplifier type XVK

Type XVR

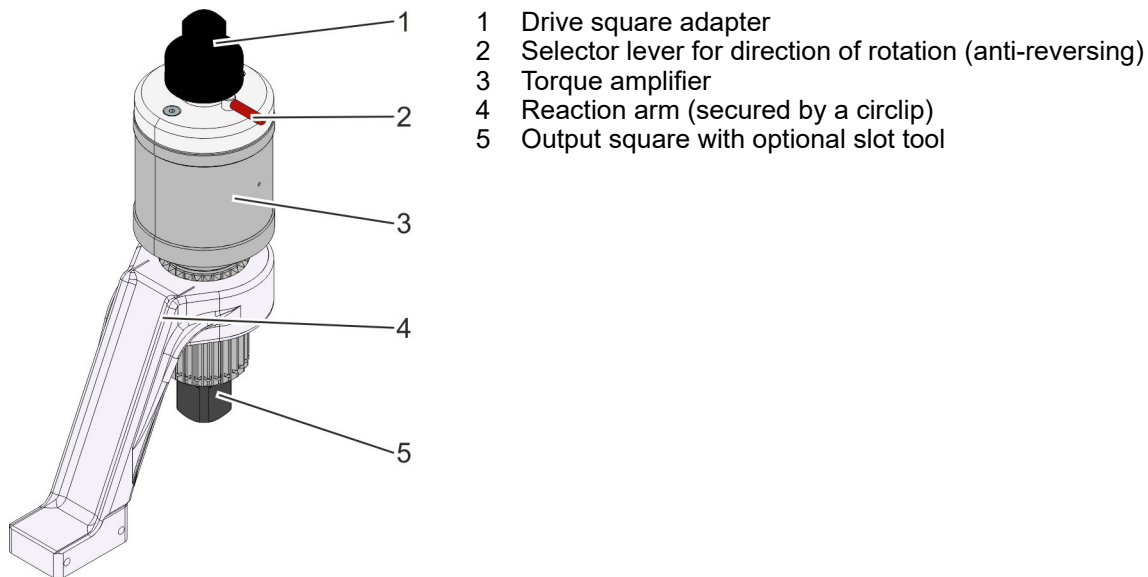

- 1 Drive square adapter
- 2 Selector lever for direction of rotation (anti-reversing)
- 3 Torque amplifier
- 4 Reaction arm (secured by a circlip)
- 5 Output square with optional slot tool

Fig. 2: Illustration of torque amplifier type XVR



Type XVR-D 45

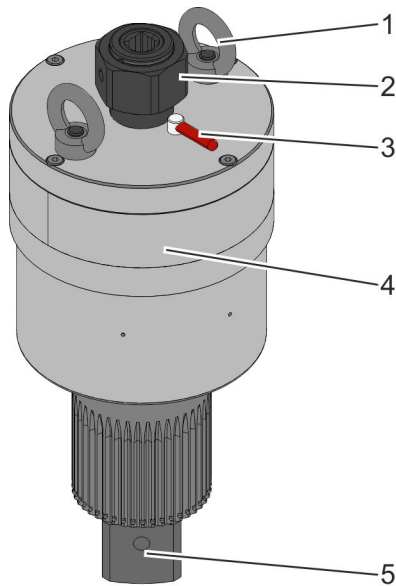

- 1 Eye nut for transport
- 2 Square drive (gear 1)/hex drive (gear 2)
- 3 Selector lever for direction of rotation (anti-reversing)
- 4 Torque amplifier
- 5 Output square with optional slot tool

Fig. 3: Illustration of torque amplifier type XVR-D 45

Ratchet

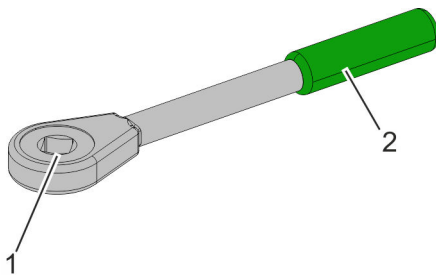

- 1 Square drive slot
- 2 Handle

Fig. 4: Illustration of ratchet

Brief description

Torque amplifiers use a specific gear reduction ratio to amplify the torque applied using a manual ratchet or manually operated torque wrench (referred to in the following as “application tool”).

The torque amplifier is attached to an application tool and then used together with the tool bit required for the fastening operation in question. The reaction arm allows the tool to be braced against an abutment (bracing point).

The various models are suitable for different fastening operations according to the torque required. The achieved output torque is determined by the torque amplifier’s specific gear reduction ratio.

Type XVR torque amplifiers feature anti-reversing that counters the reaction forces, type XVK torque amplifiers do not.

2.2 Controls and function elements

Drive square adapter (Fig. 1/1 and Fig. 2/1)

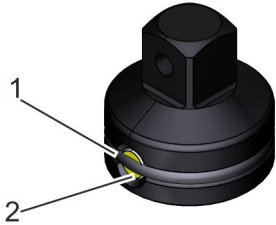

Fig. 5: Drive square adapter

The drive square adapter is used to attach the tool to an application tool. The application tool is slotted onto the square (Fig. 5) on the torque amplifier.

The drive square adapter features a shear pin (Fig. 5/2) that will break at a predetermined point in the event of tool overload. This protects the torque amplifier from damage. The shear pin is held in place by an O-ring circlip (Fig. 5/1). In the event of a defect, the O-ring circlip can be removed and the defective shear pin can be pushed out of the drive square adapter and replaced.

Square drive/hex drive XVR-D 45 (Fig. 3/2)

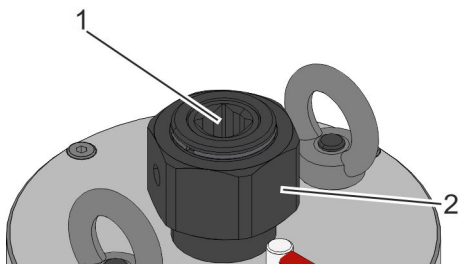

Fig. 6: Square drive/hex drive

The square drive/hex drive is used to attach the tool to an application tool, e.g. a ratchet or torque wrench. The application tool is slotted onto the square or hex mount on the torque amplifier.

The torque amplifier features two gears. The mounted bit determines which torque amplifier gear to use. A 1/2" square (Fig. 6/1) uses gear 1, a size 41 hex adapter socket on the hex drive (Fig. 6/2) uses gear 2.

Selector lever for direction of rotation (Fig. 2/2 and Fig. 3/3)

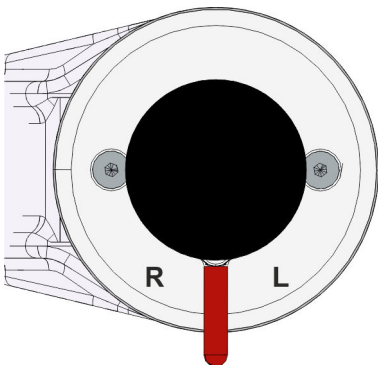

Fig. 7: Selector lever for direction of rotation

The selector lever is used to select the direction of rotation and to engage anti-reversing.

To engage anti-reversing, the selector lever needs to be set to the respective direction of rotation's position before using the torque amplifier.

The three lever positions and their associated directions of rotation are printed on the torque amplifier's housing.



Direction of rotation setting

Markings on the housing	Direction of rotation
[R]	Clockwise (CW) Tightening in clockwise direction
[0]	Anti-reversing disabled
[L]	Anti-clockwise (CCW) Loosening in anti-clockwise direction

**Torque amplifier
(Fig. 1/2 and Fig. 2/3 and Fig. 3/4)**

The torque amplifier is designed to amplify the input torque applied by an application tool (e.g. a ratchet or torque wrench). Torque amplification is achieved by means of a planetary gear set with a specific transmission ratio.

Reaction arm (Fig. 1/3 and Fig. 2/4)

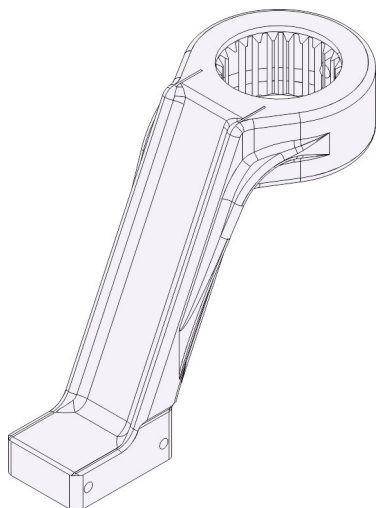

The reaction arm is used to brace the torque amplifier.

To fully counter the reaction forces, the reaction arm must be attached to the torque amplifier and braced in full contact against a suitable abutment before using the torque amplifier.

Fig. 8: Reaction arm

Output square (Fig. 1/4 and Fig. 2/5 and Fig. 3/5)

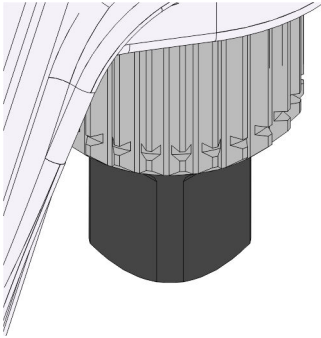

The output square is used to mount tool bits. The tool bit is slotted onto the output square and fastened using a suitable fastener (e.g. spring clip).

Fig. 9: Output square

2.3 Rating plate



The following data is inscribed on the rating plate:

- Name of the manufacturer including their full address
- Product name
- Type designation
- Serial number



Fig. 10: Rating plate (example)

2.4 Accessories

The following accessories are available for ordering together with the torque amplifier and may be included in the delivery:

- Tool bits
- Torque wrench

Special accessories



Contact PLARAD[®] service.

3 Accessory instructions: torque wrench PH Z

3.1 Illustration

Variants and technical data

PLARAD[®] torque wrenches are available in three sizes for various fastening operations.

Type	Length [mm]	Weight [kg]	Torque [Nm]	Output
PH 36 Z	663	1.6	60 – 360	½"
PH 50 Z	1040	6	200 – 500	¾"
PH 76 Z	1280	6.8	300 – 800	

For more details, visit <https://www.plarad.de/download-center.html>

Illustration example PH 36 Z

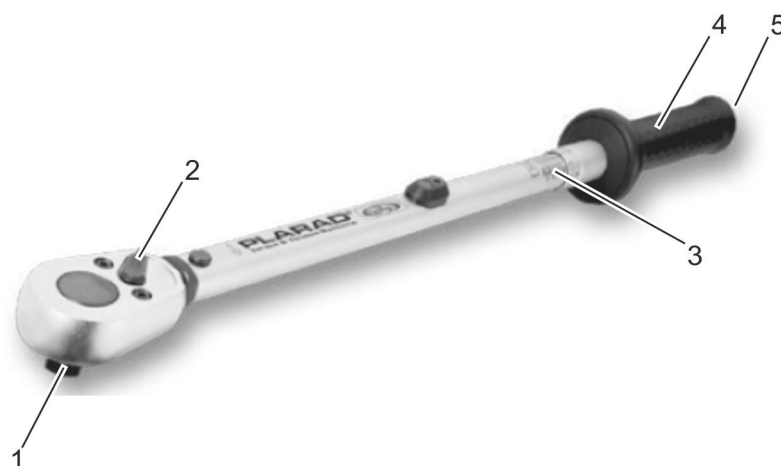

Fig. 11: Illustration example PH 36 Z

- 1 Output square
- 2 Selector lever for direction of rotation
- 3 Torque scale
- 4 Handle
- 5 Dial (blue) for unlocking the handle (on handle underside)

Brief description

The torque wrench is used to tighten or loosen bolted connections to a defined torque.

To set the torque, the handle (Fig. 11/5) can be unlocked using the dial (Fig. 11/6) and the required torque set on the torque scale (Fig. 11/4) by turning the handle. The handle is then locked again using the dial.

The direction of rotation can be set using the selector lever (Fig. 11/2). The torque wrench then locks the other respective direction. The output square (Fig. 11/1) allows attachment of the torque amplifier. The button (Fig. 11/3) is used to unlock the tool.

Technical data sheet



Technical data sheet is available online at: <https://www.plarad.de/download-center.html>

Additional specifications

The torque wrench features a serial number.

3.2 Intended use

Torque wrenches must be used exclusively to tighten or loosen bolted connections in conjunction with manual lug or socket wrenches within the respective load specifications. Only matching tool bits may be used on the output square that are designed for the fastening operation in question.

Intended use includes compliance with all of the stipulations in this manual.

Any use beyond the intended use as well as any other use is considered misuse.

3.3 Using the torque wrench

- Personnel: Qualified personnel
- Protective equipment: Protective work clothing
- Safety shoes

Setting the direction of rotation

1.  Move the selector lever for direction of rotation into the desired position.



When switching the direction of rotation after loosening or tightening a bolted connection, make sure that the torque wrench is no longer subject to any load. The lever may otherwise lock up.

⇒ The torque wrench runs in the set direction of rotation.

Setting the torque

2.  Turn the dial clockwise.
 - ⇒ The handle is unlocked.



3. ➔



NOTICE!

Risk of inadequate fastening if the torque wrench is used incorrectly!

Push the handle forwards and turn it to set the desired torque on the torque scale. Always choose the torque to match the torque chart of the torque amplifier being used for the fastening operation.



The scale marks on the handle must align centrally with the scale marks on the ratchet.

4. ➔

Release the handle.

⇒ The handle automatically snaps into place on the scale mark. The torque indicated by the torque scale has been set.

5. ➔

Turn the dial anti-clockwise.

⇒ The handle is locked. The torque wrench can be used with the torque amplifier.

3.4 Torque wrench maintenance

Maintenance tasks

See the following for a list of regularly required maintenance tasks.

If routine checks reveal increased wear, shorten the requisite maintenance intervals according to the actual signs of wear. If you have questions about maintenance tasks and intervals, contact PLARAD[®] service.

Interval	Maintenance task	Personnel
every 2 years or, if used continuously, weekly	Have torque accuracy verified	PLARAD [®] service

Accessories, spare parts and wear parts

Spare parts must meet the technical requirements specified by PLARAD[®]. This is always ensured by original spare parts. A warranty can only be provided for original spare parts supplied by PLARAD[®].

The installation or use of other spare parts can, under certain circumstances, adversely alter the specified design properties and, consequently, impair active or passive safety.

Any liability and warranty for damage resulting from the use of parts other than the original spare parts and accessory parts is excluded.

Have at least the following information to hand to enable quick and easy order processing:

- Client
- Type and serial number of the torque wrench
- Desired spare part
- Desired quantity
- Desired mode of shipping

🔗 *'PLARAD[®] service' on page 4*

3.5 Disposing of the torque wrench

The torque wrench must be disposed of in an environmentally sound manner at the end of its service life.

Insofar as no take-back or disposal agreement has been put in place, dispose of the torque wrench in accordance with local regulations for metal. Use authorised collection points for reprocessing.

If in doubt, obtain information about environmentally sound disposal from the local municipal authority or from specialist disposal companies.



4 Before you begin – safety

This section provides an overview of all safety aspects that are essential to the best possible protection of the personnel and the safe and trouble-free operation of the machine. Additional safety instructions for specific work tasks are contained in the sections regarding the individual life stages of the machine.

4.1 Symbols in this manual

Safety warnings

Safety warnings in this manual are indicated by symbols. Safety warnings are introduced by signal words that identify the severity of the hazard.



WARNING!

This combination of symbol and signal word indicates a potential danger that may cause serious injury or death if not avoided.



CAUTION!

This combination of symbol and signal word indicates a potential danger that may cause minor or slight injury if not avoided.



NOTICE!

This combination of symbol and signal word indicates a potential danger that may cause damage if not avoided.



ENVIRONMENT!

This combination of symbol and signal word indicates potential pollution of the environment.

Safety warnings in step-by-step instructions

Safety warnings may apply to specific, individual instructions. Such safety warnings will be embedded in the list of instructions to maintain readability when executing the respective action. The signal words listed above are used.

Example:

1. ➔ Loosen the bolt.

2. ➔



CAUTION!

Risk of getting trapped by lid!

Close lid carefully.

3.  Tighten the bolt.





Tips and recommendations



This symbol highlights useful tips and recommendations as well as information to help you use your equipment efficiently and without disruption.

Other markings

The following markings are used in this manual in order to highlight instructions, outcomes, lists, references and other elements:

Marking	Explanation
	Step by step instructions
	Outcomes of steps
	References to sections of this manual and to other applicable documents
	Lists without a fixed order
[Button]	Controls (e.g. buttons, switches), indicators (e.g. signal lamps)
'Display'	Display elements (e.g. on-screen buttons, assignment of function keys)

4.2 Symbols on the torque amplifier

Illustration of symbols on the torque amplifier



Fig. 12: Symbols on torque amplifier and reaction arm

- 1 Rating plate
- 2 
- 3 
- 4 



Besides the symbols shown here, the torque amplifier features additional function markings and may feature additional test badges.

Illegible signage



WARNING!

Danger in the event of illegible signage!

Over time, signs and stickers can become dirty or be rendered unrecognisable by other means, such that hazards cannot be recognised and necessary operating instructions cannot be followed. This creates a danger of injury.

- Keep all safety notices, warnings and operating instructions in a clearly legible state at all times.
- Replace damaged signs and stickers immediately.

The following symbols and markings are used on the torque amplifier and reaction arm:

Permissible torque



The stated value indicates the maximum permissible torque for the reaction arm.

Follow the manual



Read the operating instructions before use.

Danger of crushing



Keep your hands away from areas bearing this warning.

There is a danger of body parts being crushed, pulled in or otherwise injured.

It is necessary to pay greater attention when performing work at the marked locations.

Test badges

The test badges state the dates of the respective tests.



Date of the next PLARAD[®] service



For torque amplifier with certificate:

Date of the last torque inspection

Gear marking

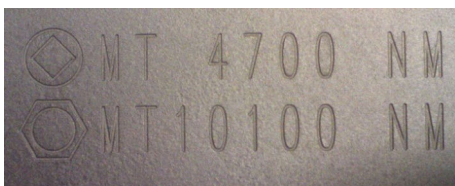

The housing of the type XVR-D 45 torque amplifier features torque values for the two gear settings using the square drive (gear 1) or the hex drive (gear 2).

Direction of rotation setting



The various lever positions and their associated directions of rotation are printed on the type XVR torque amplifier's housing (↪ *Chapter 2.2 'Controls and function elements' on page 10*).



4.3 Intended use

Torque amplifiers must be used exclusively to tighten or loosen bolted connections in conjunction with a manual ratchet or a manual torque wrench (application tool) within the respective load specifications. They may only be used together with an intact and properly positioned reaction arm. Only matching tool bits may be used on the output square that are designed for the fastening operation in question. Torque amplifiers may only be used with an inserted original, intact shear pin.

Intended use includes determining the type of torque amplifier and the input torque required for the respective fastening operation by consulting the torque chart before the torque amplifier is used.

Intended use includes compliance with all of the stipulations in this manual.

4.4 Misuse

Any use beyond the intended use as well as any other use is considered misuse.



WARNING!

Danger in the event of misuse!

Misuse of the torque amplifier can lead to dangerous situations.

- Never use with motorised output shafts or tools.
- Never use without the reaction arm.
- Never subject the torque amplifier, bolts or accessories to loads exceeding the permitted torque.
- Never use if braced inadequately.
- Never use outside of permissible environmental conditions.
- Never carry out fastening operations that do not include the employed type of torque amplifier in the torque chart.
- Never use with defective or non-original shear pin.

4.5 Residual risks

The following section outlines the residual risks potentially posed by the torque amplifier even when it is used as intended.

To reduce the risks of injury and damage and to avoid dangerous situations, observe the safety warnings listed here and the safety warnings in the other sections of this manual.

4.5.1 Mechanical dangers

Missing safety devices



WARNING!

Danger of injury from inoperative or missing safety devices!

Inoperative or missing safety devices may lead to serious injury.

- Prior to commencing work, check that all safety devices are operative and correctly installed.
- Never disable or remove safety devices.

Torque amplifiers are equipped with the following safety devices:

- Anti-reversing (type XVR only)
Anti-reversing prevents the square drive from turning in reverse when high tightening torques are applied.
- Shear pin with O-ring circlip
There is a shear pin inserted into the drive square adapter. The shear pin will snap when torque is too high. The shear pin is held in place by an O-ring circlip.
- Reaction arm circlip
The reaction arm is protected against outward ejection by means of a circlip.
- Tool bit fastener
The tool bit is secured against outward ejection by a suitable fastener (e.g. spring clip) on the torque amplifier's output square.

High torques



WARNING!

Danger of injury from high torque!

Torque amplifiers produce high torque. Torque builds up during the fastening operation. There is a danger of crushing between the reaction arm and bracing surface during tightening and loosening.

When relieving the torque amplifier, some of the torque applied during the fastening operation is transferred to the application tool. The application tool may reverse in an uncontrolled manner and cause serious injury.

- Do not reach between the reaction arm and bracing surface during the fastening operation.
- Observe the notes on relieving the torque amplifier in this manual.



Mechanical overload



WARNING!

Danger of injury from mechanical overload!

Mechanically overloading the torque amplifier or individual components may lead to injuries or may damage the torque amplifier.

- Do not use the torque amplifier if the particulars of the fastening operation are not entirely clear.
- Note the torque chart.
- On torque amplifiers with anti-reversing, set the direction of rotation correctly for the respective fastening operation.
- Observe the notes on safely bracing the reaction arm in this manual.
- Always check the applied input torque when tightening or loosening bolted connections.
- Never jerk the application tool when tightening or loosening bolted connections.
- When using a torque wrench to tighten a bolted connection, only tighten the bolted connection until the set torque has been achieved and the torque wrench triggers for the first time. Do not turn excessively.
- When loosening bolted connections, always use a torque wrench and observe the maximum permitted torque for the torque amplifier used in order to prevent unexpectedly high torques.
- Use only PLARAD[®] original parts.

High weight



WARNING!

Danger of injury from high weight of the torque amplifier!

The torque amplifier is very heavy. When falling from great heights, the torque amplifier may cause serious injury.

- Allow only persons who are physically capable of using the torque amplifier safely to perform any work.
- When working at height, secure the torque amplifier to prevent it from falling.
- Wear safety shoes. Also wear an industrial safety helmet for overhead work.
- Always take into account its weight when working or when transporting it.
- Handle the torque amplifier with care and as intended.

4.5.2 Ergonomics

Inadequate ergonomics



WARNING!

Injuries to the musculoskeletal system due to unhealthy work posture!

Unhealthy work postures can cause permanent damage to the musculoskeletal system over the long term.

- Ensure stable footing and sufficient room for movement.
- Keep your back as straight as possible. Do not work with your upper body hunched over, bent forward, or with your back arched.
- Avoid lopsided lifting. Avoid twisting your spine.
- Never move the application tool abruptly.

Dirt and scattered objects



CAUTION!

Danger of injury from falling due to dirt and scattered objects!

People may slip on or stumble over dirt and scattered objects. Falling may cause injuries.

- Always keep the work area clean.
- If objects are no longer needed, remove them from the work area and especially if such objects are at ground level.
- Mark unavoidable stumbling points with hazard tape.
- Keep handles and gripping surfaces of the ratchet or torque wrench dry, clean and free of lubricants. Clean them immediately if they are dirty.

4.6 Notes on use

Quality of bolted connections

Continued use changes the torque amplifier's torque multiplier due to a change in efficiency.



The supplied torque chart applies to calibrated tools. For tools that have not been calibrated, PLARAD[®] guarantees a repetition accuracy of $\pm 10\%$. To perform fastening operations that require greater repetition accuracy, the torque amplifier requires calibration. After calibration, repetition accuracy of $\pm 5\%$ is guaranteed.

**Conserving materials**

Torque amplifiers used frequently at load limit may suffer premature wear.



To avoid premature damage to tools and accessories, ideally use torque amplifiers that can produce up to around twice the torque required for the respective fastening operation. Use torque greater than 80% (of the torque amplifier's maximum torque) only in exceptional cases.

Also bear in mind that loosening bolted connections may entail far higher loads than tightening.

4.7 Operator's obligations

The torque amplifier is used in the commercial sector. The operator of the torque amplifier is therefore subject to the statutory obligations pertaining to occupational safety.

In addition to the safety instructions in this manual, the applicable safety, occupational safety and environmental protection regulations for the torque amplifier's area of application must be adhered to.

The following specifically applies in this regard:

- Operators must familiarise themselves with the applicable occupational safety regulations and, as part of a risk assessment, determine additional dangers that arise as a result of the specific operating conditions at the torque amplifier's operating site. The findings of this risk assessment must be used to draft safety instructions for operating the torque amplifier.
- During the entire time the torque amplifier is in use, the operator must check whether the safety instructions they have compiled reflect current regulations and, if necessary, the operator must change the instructions accordingly.
- The operator must clearly define and regulate responsibilities for all work on and with the torque amplifier. The authority and responsibilities of personnel regarding operation, set-up, maintenance and repair must be clearly defined.
- The operator must reliably check the use of the torque amplifier and ensure that only commissioned and instructed personnel work with the torque amplifier. Personnel being trained or instructed and personnel undertaking vocational training must always be supervised by an experienced person when working with or on the torque amplifier.
- The operator must ensure that the torque amplifier is not opened and that no work is performed by unauthorised persons.

The operator is also responsible for ensuring that the torque amplifier is in technically flawless condition at all times. The following applies for this reason:

- The operator must ensure adherence to the maintenance intervals described in this manual.
- The operator must have the functionality and integrity of all safety devices checked on a regular basis.



4.8 Who is permitted to use the torque amplifier?



WARNING!

Danger of injury if personnel are insufficiently qualified!

If unqualified personnel perform work on or with the torque amplifier or if such persons are present in the danger zone while work is being performed, dangers arise that could cause serious injuries and considerable property damage.

- Have all tasks performed by suitable qualified personnel without exception.
- Keep unqualified personnel away from the danger zones and work areas.

User

The user of the torque amplifier has the requisite knowledge and the requisite training for handling torque amplifiers. Furthermore, during training by the operator, users have been trained in relation to the tasks assigned to them and the potential dangers associated with improper conduct.

The user is trained in how to use the personal protective equipment, is familiar with the most important specifications, situations and information relating to the specific application and is physically capable of using the torque amplifier safely. This includes overhead work, working at heights, etc.

The user must be of at least the legally permissible minimum age.

Users may only perform tasks that exceed operation under normal operating conditions if this is specified in this manual and the operator has expressly entrusted the users with the performance of such tasks.

The user knows who their supervisor is, can contact their supervisor if they have questions or in an emergency, and is able to communicate with their supervisor.

The user is familiar with all residual risks and is trained in the practical handling of the torque amplifier.

Qualified torque amplifier personnel

Qualified torque amplifier personnel are trained for the specific task area in which they work and are familiar with the relevant standards and regulations.

Due to their professional training and experience, qualified torque amplifier personnel are able to perform work with the torque amplifier, recognise and avoid potential dangers independently and indicate them to users.

Specific capabilities of qualified torque amplifier personnel include:

- Identify the particulars of a fastening operation.
- Prepare the torque amplifier.
- Choose appropriate tool bits and application tools.
- Uphold safety, occupational safety and health protection when using the torque amplifier and convey this to users.

- Identify damage on the torque amplifier and arrange for repairs or get in touch with the manufacturer.
- Instruct users in the proper manner.

Operator

The operator is the person who operates the torque amplifier for commercial or economic purposes themselves, or makes it available for a third party to use, and who bears legal responsibility for the product vis-à-vis protection of personnel and third parties during operation.

🔗 *Chapter 4.7 'Operator's obligations' on page 26*

PLARAD[®] service

Certain work may only be performed by PLARAD[®] service or by personnel authorised by Maschinenfabrik Wagner GmbH & Co. KG. Other personnel are not authorised to perform this work. Contact PLARAD[®] service or authorised PLARAD[®] partners regarding performance of the work that is due.

Contact: www.plarad.de

Unauthorised persons



WARNING!

Danger of death for unauthorised persons due to dangers in the danger zone and work area!

Unauthorised persons, who do not meet the requirements described in this manual, are not aware of the dangers in the danger zone. There is therefore a danger of serious injuries or even death for unauthorised persons.

- Keep unauthorised persons away from the danger zone and work area.
- If in doubt, address the respective persons and instruct them to leave the danger zone and work area.
- Suspend work while there are unauthorised persons loitering in the work and danger zone.

4.9 Personal protective equipment

Industrial safety helmet



Industrial safety helmets are used to protect the head from falling objects, suspended and swinging objects and from bumping into stationary objects.

An industrial safety helmet must be worn for overhead work involving the nutrunner.



Safety goggles



Safety goggles are used to protect the eyes from airborne parts and liquid jets.

Protective work clothing



Protective work clothing is tight fitting work clothing with a low tearing resistance, with tight sleeves and without any protruding parts.

Safety gloves



Safety gloves are used to protect the hands from friction, abrasions, punctures or deeper injuries and from contact with hot surfaces.

Safety shoes



Safety shoes protect the feet from crushing, falling parts and from slipping on slippery ground.

4.10 Environmental protection



ENVIRONMENT!

Danger of pollution from incorrect handling of environmentally hazardous substances!

If environmentally hazardous substances are handled incorrectly, especially if such substances are disposed of incorrectly, this could cause significant damage to the environment.

- Always adhere to the instructions given below in relation to the handling of environmentally hazardous substances and the disposal thereof.
- If environmentally hazardous substances accidentally enter the environment, adopt suitable measures immediately. If in doubt, notify the competent local authority of the damage and inquire about suitable measures to be taken.

The following environmentally hazardous substances are used:

Lubricants

Lubricants, such as greases and oils, contain toxic substances. Such substances must not enter the environment.

Arrange for such substances to be disposed of by a specialist disposal company.



5 Using the torque amplifier

Tools and accessories



WARNING!

Danger of injury due to selection of inappropriate tools and accessories or incorrect use!

Choosing inappropriate tools and accessories or using them incorrectly entails a danger of injury and a risk of damage to the torque amplifier and accessories.

- Observe the safety notes and instructions on choosing and using the torque amplifier and any accessories.

Inadequate bracing



WARNING!

Danger of injury from incorrect bracing, overloading, breakage!

If the torque amplifier is not sufficiently braced, it can slip out of place. Any point contact between the reaction arm and the corners of a bracing element can cause considerable forces to act on the torque amplifier. Incorrect bracing or overloading of the reaction arm, bolts or other components can result in serious injuries and damage the torque amplifier.

- Check the reaction arm for visible damage prior to use. Do not use the reaction arm if it is damaged.
- Always ensure that the reaction arm is in full contact with the surface.
- Do not use the torque amplifier if it is impossible to brace it safely.

Relieving the torque amplifier



WARNING!

Danger of injury from high torque when relieving the torque amplifier!

When relieving the torque amplifier, some of the torque applied during the fastening operation is transferred to the application tool. The application tool may reverse in an uncontrolled manner and cause serious injury.

- Be prepared for the high torque that acts on the application tool when relieving.
- Guide the application tool slowly and with controlled movements to relieve the torque amplifier.

Application tool and tool bits



NOTICE!

Damage from incorrect attachment and improper use of application tools and tool bits!

- Use only application tools and tool bits suitable for the fastening operation.
- Ensure a flawless, positive connection between the torque amplifier, tool bits and bolt.
Ensure that there is a positive connection between the tool mount (torque amplifier's output square) and square mount of the tool bit.

Loosening bolted connections



NOTICE!

Damage from improperly loosening bolted connections!

Loosening a bolted connection frequently requires greater torque than fastening it. If the required torque is unknown, the torque amplifier and accessories may suffer damage.

- To reliably avoid overload, it is recommended to use a torque wrench wherever possible to loosen bolted connections.
- If necessary, pre-treat seized bolted connections, for example with penetrating oil.
- Ensure that all tools and accessories are designed for this load.

5.1 Determining the particulars of the fastening operation

Information about bolted connections

The torque amplifier reacts differently to “soft” and “hard” bolted connections. “Soft” and “hard” bolted connections themselves each react differently to each other, as the thread and lubrication state can vary from bolted connection to bolted connection.

The correct input torque must be chosen separately for every fastening operation and checked directly during the fastening operation.

Use a calibrated torque wrench to check.

- Personnel:
- Operator
 - Qualified personnel

To determine the particulars of the fastening operation, proceed as follows:

1.  Determine a suitable bracing surface and select a suitable reaction arm for proper bracing.

Determine the appropriate tool bit.



2. → Determine the requisite torques and angles for the fastening operation.

To do so, measure the torque applied during a bolting process with a calibrated torque wrench.

3. → Make any further required tools and accessories available according to the situation.

5.2 Safe bracing

Reaction arm

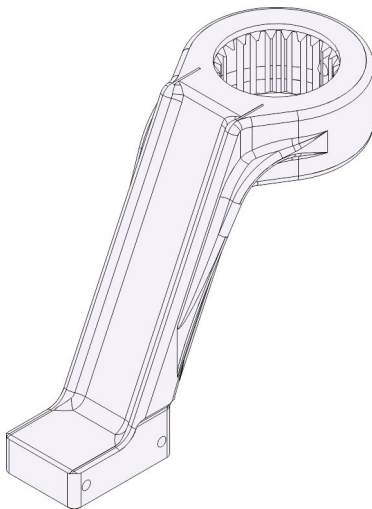

Fig. 13: Standard reaction arm

High torque can only be generated if the reaction forces are absorbed. This is the reaction arm's purpose.

The torque amplifier is supplied with a standard reaction arm. The torque amplifier may only be used with the supplied reaction arm.

For fastening operations for which the standard reaction arm is unsuitable, contact PLARAD[®] service.

Notes on safe bracing



Fig. 14: Bracing the reaction arm correctly

Observe the following conditions when determining ideal bracing for the fastening operation:

- Correct bracing point
- Incorrect bracing point

- The reaction arm's side surface must lie flush in full contact on the bracing surface (e.g. adjacent bolt, housing). It must not lie only on the corner of a bracing point or against a bracing surface around a corner.

If the standard reaction arm does not allow safe bracing in your fastening operation, consult PLARAD[®] service.

5.3 Tightening

- Personnel: User
 Qualified personnel
- Protective equipment: Industrial safety helmet
 Protective work clothing
 Safety gloves
 Safety shoes

1. ➤ Ensure that the fastening operation is known.
2. ➤ Choose the appropriate type of torque amplifier for the fastening operation according to the torque chart.
3. ➤ Choose a tool bit and application tool appropriate to the fastening operation.
4. ➤ Turn the output square on the torque amplifier through several revolutions by hand in order to distribute the grease in the gearbox evenly.

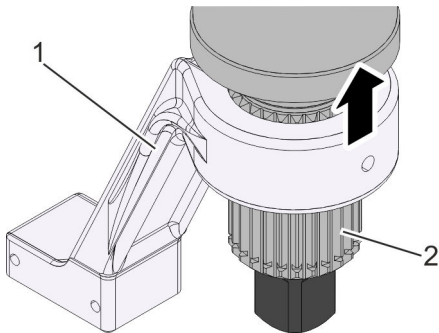



Fig. 15: Assembling the reaction arm

5. ➤  **WARNING!**
Danger of injury from inoperative or missing safety devices!

Push the reaction arm (Fig. 15/1) onto the serration (Fig. 15/2) on the torque amplifier and fasten it with a circlip.

6. ➤ Mount the tool bit on the torque amplifier's output square and fasten it securely (e.g. with a spring clip).

7. ➤  **NOTICE!**
Damage from incorrect attachment and improper use of application tools and tool bits!

Attach the torque amplifier with the tool bit to the bolted connection in such a way that the full height of the bolt head or nut is gripped by the tool bit.

If this is impossible, change the tool bit for one that matches the requirements of the fastening operation.

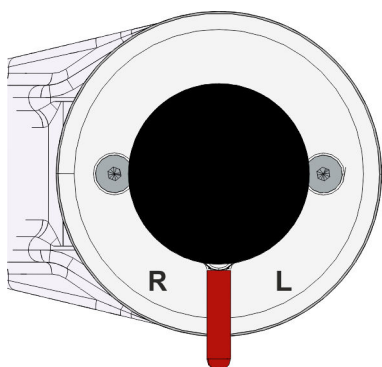

Fig. 16: Selector lever for direction of rotation

8. On torque amplifiers with anti-reversing, move the selector lever for direction of rotation into the desired position.

Markings on the housing	Direction of rotation
[R]	Clockwise (CW) Tightening in clockwise direction
[0]	Anti-reversing disabled
[L]	Anti-clockwise (CCW) Loosening in anti-clockwise direction

9. Set the application tool's direction of rotation to the same direction as the torque amplifier's.

- 10.



WARNING!
Danger of injury from insufficient bracing!

Turn the reaction arm counter to the desired direction of rotation and lay it safely against a suitable bracing surface. Ensure that the reaction arm is in full contact with the surface.

11. Slot the application tool onto the torque amplifier's square drive.



When using the XVR-D 45:

- When tightening a bolted connection, first use an application tool with square drive.
- When loosening a bolted connection, first use an application tool with a size 41 hexagon adapter socket.



When using a torque wrench:

- To tighten a bolted connection, set the torque wrench to the input torque required for the bolted connection according to the torque chart. The input torque to be set is indicated in the chart based on the required output torque.
- To loosen a bolted connection, set the torque wrench to the maximum permitted input torque of the torque amplifier used according to the torque chart. The input torque to be set is indicated in the last line in the chart.



NOTICE!

Damage from improperly loosening bolted connections!

- 12.** ▶
- Tightening a bolted connection: Tighten the bolted connection to the required torque.
 - Loosening a bolted connection: Fully loosen the bolted connection.



When using the XVR-D 45:

- *When tightening, use gear 1 with square drive until you reach an input torque of 4,700 Nm. For higher torque, use gear 1 with hexagon adapter socket.*
- *When loosening, use gear 2 with hexagon adapter socket until the input torque drops below 4,700 Nm. After this, use gear 2 with square drive.*

13. ▶



WARNING!

Danger of injury from high torque!

To relieve the torque amplifier, turn the application tool through only a few degrees of arc and set the torque amplifier's selector lever for direction of rotation to neutral [0]. Be prepared for the high torque that acts on the application tool when relieving.

- 14.** ▶ Move the application tool back counter to the direction of rotation slowly and with controlled movements until the torque amplifier is fully relieved.

⇒ The torque amplifier is relieved.

- 15.** ▶ Take the torque amplifier off the bolted connection.



When using a simple ratchet:

- *Check the torque achieved using a suitable torque measuring instrument.*



6 Performing maintenance

6.1 Maintenance schedule

Improperly performed maintenance tasks



WARNING!

Danger of injury and property damage due to improperly performed maintenance tasks!

Improperly performed maintenance tasks can cause injury, damage the torque amplifier and result in insufficient bolted connections.

- Perform all maintenance tasks regularly in accordance with this manual.
- Only use genuine parts and lubricants recommended by PLARAD[®].

Faultless operation

The following sections describe the maintenance tasks that are required in order to ensure optimum and faultless operation.

If routine checks reveal increased wear, shorten the requisite maintenance intervals according to the actual signs of wear. If you have questions about maintenance tasks and intervals, contact PLARAD[®] service.

Interval	Maintenance task	Personnel
every 10 operating hours	Relubricate gearbox ↳ Chapter 6.2 'Relubricating the gearbox' on page 38	User Qualified personnel
every 12 months, according to repetition accuracy required	Have torque amplifier calibrated	PLARAD [®] service
as required/after snapping	Replace shear pin ↳ Chapter 6.3 'Replacing the shear pin' on page 38	Qualified personnel

Accessories, spare parts and wear parts

Spare parts must meet the technical requirements specified by PLARAD[®]. This is always ensured by original spare parts. A warranty can only be provided for original spare parts supplied by PLARAD[®].

The installation or use of other spare parts can, under certain circumstances, adversely alter the specified design properties and, consequently, impair active or passive safety.

Any liability and warranty for damage resulting from the use of parts other than the original spare parts and accessory parts is excluded.

Have at least the following information to hand to enable quick and easy order processing:

- Client
- Type and serial number of the torque amplifier
- Desired spare part
- Desired quantity
- Desired mode of shipping

🔗 'PLARAD[®] service' on page 4

6.2 Relubricating the gearbox

- Personnel:
- User
 - Qualified personnel
- Protective equipment:
- Safety goggles
 - Protective work clothing
 - Safety gloves
 - Safety shoes
- Tool:
- Grease gun
- Material:
- Mobil Temp SHC 100

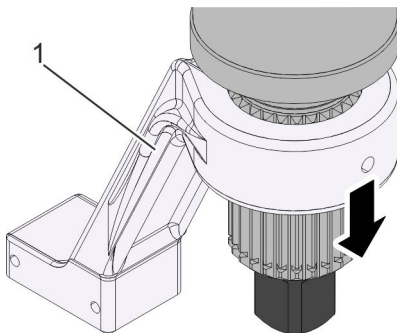

Fig. 17: Removing the reaction arm

1. ➤ Remove the tool bit.
2. ➤ Remove the reaction arm. To do so, first remove the circlip and slide out the reaction arm (Fig. 17/1) downwards.
3. ➤ Use the grease gun to fill lubricant in through the grease nipple on the serration (1 to 2 strokes).
 - ⇒ The torque amplifier's gearbox has been relubricated.

6.3 Replacing the shear pin



WARNING!

Danger of injury from using unsuitable shear pins!

The shear pin protects the torque amplifier from damage by snapping when the torque amplifier overloads. A broken shear pin must be replaced. Replacing the shear pin with an unsuitable one will cause a danger of injury and a risk of irreparable damage to the torque amplifier.

- Never replace the shear pin with a normal pin or bolt.
- Use only PLARAD[®] original parts.



- | | |
|-----------------------|-------------------------------------|
| Personnel: | ■ Qualified personnel |
| Protective equipment: | ■ Safety goggles |
| | ■ Protective work clothing |
| | ■ Safety gloves |
| | ■ Safety shoes |
| Tool: | ■ Punch tool with hammer (optional) |
| Material: | ■ Replacement shear pin |

1. ➤ Remove the circlip (Fig. 18/1) from the drive square adapter.

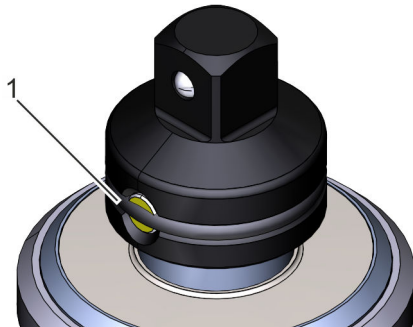

Fig. 18: Removing the drive square adapter circlip

2. ➤ Remove the shear pin (Fig. 19/1). If necessary, use a punch tool to drive out the shear pin.

3. ➤ Insert a new shear pin.

4. ➤ Clip the circlip into the groove on the drive square adapter level with the shear pin.

⇒ The shear pin has been replaced.

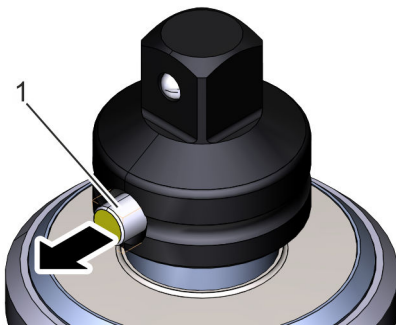

Fig. 19: Removing the shear pin

7 Disposing of the torque amplifier

The torque amplifier must be disposed of in an environmentally sound manner at the end of its service life.

Disassembly

1. ▶ Remove the application tool, tool bit and reaction arm.
2. ▶ Remove the circlip, shear pin and drive square adapter.

Disposal

Insofar as no take-back or disposal agreement has been put in place, dispose of the torque amplifier in accordance with local regulations. Use authorised collection points for reprocessing.



ENVIRONMENT!

Danger to the environment due to incorrect disposal!

Incorrect disposal can be hazardous to the environment.

- Dispose of the torque amplifier as hazardous waste according to the lubricant safety data sheet.
- Recycle the transport case, removed metal parts of the torque amplifier and the circlip according to their material composition.

If in doubt, obtain information about environmentally sound disposal from the local municipal authority or from specialist disposal companies.



8 Technical data

Technical data sheet



Technical data sheet is available online at: <https://www.plarad.de/download-center.html>

Type*	Height [mm]	Diameter [mm]	Weight [kg]	Performance range [Nm]	Drive	Output	Transmission ratio
XVK 15	172	81	2.6	220 – 1,700	¾"	1"	1 : 4
XVR 25	302		5.2	440 – 2,300			1 : 7
XVR 35	273		5	510 – 3,600			1 : 10
XVR 40	238	95	6.1	560 – 4,000		1½"	1 : 11
XVR 65	244	114	8.4	820 – 6,200			1 : 15
XVR 70	302	128	11.4	980 – 6,800			1 : 17
XVR 90	300	172	21.8	1,780 – 8,600			1 : 32
XVR-D 45	310	128	16	1,000 – 10,100			1 : 22 (2-speed)

* - Type XVR torque amplifiers feature anti-reversing that counters the reaction forces, type XVK torque amplifiers do not.

Ambient conditions

Data	Value	Unit
Temperature range	0 – 50	°C

9 Index

- A**
- Accessories 12, 13, 15, 31, 37
 - Ambient conditions 41
 - Anti-reversing 10, 35
 - Applicability 3
 - Application tools 31, 32, 34
 - Authorised partners 4
- B**
- Bolted connection
 - Loosening 32, 34
 - Quality 24
 - Tightening 34
 - Bracing 31, 33
 - Brief description
 - Torque amplifier 9
 - Torque wrench 13
- C**
- Calibration 24, 37
 - Controls and function elements
 - Torque amplifier 10
 - Torque wrench 13
 - Copyright 4
 - Customer service 4, 28
- D**
- Delivery 6
 - Determining the particulars of the fastening operation 32, 34
 - Direction of rotation setting 11, 35
 - Disassembly 40
 - Disposal
 - Torque amplifier 40
 - Torque wrench 16
 - Drive square adapter 10
- E**
- Environmental protection 29
 - Ergonomics 24
- F**
- Function
 - Torque amplifier 9
 - Torque wrench 13
- G**
- Gearbox 41
- H**
- Help 28
- I**
- Illustration 8
 - PH 36 Z 13
 - Ratchet 9
 - XVK 8
 - XVR 8
 - XVR-D 45 9
 - Intended use
 - Torque amplifier 21
 - Torque wrench 14
- L**
- Lubricant 29, 38
 - Lubricating 38
- M**
- Maintenance
 - Overview 37
 - Relubricating the gearbox 38
 - Replacing the shear pin 39
 - Maintenance schedule 37
 - Manufacturer 4
 - Maschinenfabrik Wagner 4
 - Misuse
 - Torque amplifier 21
 - Torque wrench 14
- O**
- Old devices 16, 40
 - Operating conditions 41
 - Operation 34



Operator	28	S	
Operator's obligations	26	Safety devices	22
Other applicable documents	3	Scope of delivery	6
Output	12	Selector lever for direction of rotation	10, 35
P		Service	4, 28
Packaging material	7	Shear pin	10, 21, 22, 39
Personal protective equipment	28	Signs	19
Personnel qualifications	27	Spare parts	15, 37
PLARAD customer service	28	Square drive/hex drive	10
PLARAD service	28	Stickers	19
PPE	28	Storage	7
Preparation	32, 33	Suggestion for improvement	4
Q		Symbols	
Qualified torque amplifier personnel	27	In this manual	17
Quality	24	On the torque amplifier	19
R		T	
Rating plate	12	Table	
Torque amplifier	12	Torque wrenches	13
Torque wrench	14	Technical data	41
Reaction arm	11, 22, 23, 31, 33	Torque amplifier	41
Assembling	34	Torque wrenches	13
Bracing	35	Tool bits	31, 32, 34
Removing	38	Torque chart	21, 23, 24, 34
Residual risks	21	Torque wrench	12, 13
Bracing	23, 31, 33, 35	Maintenance tasks	15
Breakage	23, 31, 32, 39	Using	14, 35
Crushing	22	Torque wrenches	
Dirt and objects	24	Variants	13
Ergonomics	24	Transmission ratio	41
Overload	23, 31, 32	Transport	7
Relieving	22, 31, 36	Transport case	6
Reversing	22, 31, 36	U	
Safety devices	22	Unauthorised persons	28
Spare parts	23	User	27
Tools	31, 32	User requirements	27
Torque	33, 36	W	
Torques	22	Wear	25
Weight	23	Weight	23, 41
		Who can I ask?	28

Workspace 24



Appendix

The following documents are supplied with the torque amplifier in a document folder in addition to this manual.

- EU declaration of conformity
- Torque chart
- Certificates (option)