

Hydraulic tool LT-series



Operating manual



Store for future reference.

Contents

1. Manufacturer	3
2. Preface	3
3. Information on safe working and accident prevention	4
4. Operating principle	5
5. General information	5
6. Before putting the electric power pack into operation	6
7. Before putting the pneumatic power pack into operation	6
8. Before putting the device into operation	7
9. Setting the torque	7
10. Mode of operation	8
11. Avoiding and correcting faults	9
12. Guidelines on positioning and arranging the reaction arm	12

1. Manufacturer

Maschinenfabrik Wagner GmbH & Co. KG
53804 Much, Germany
+49 (02245) 62-0

2. Preface

Read this operating manual carefully before putting the system into operation. This is for your own protection and will provide you with important information on how to connect and use the system in a safe manner.

The operational accuracy and service life of the system depend, in no small part, on how it is handled by the operating personnel.

The manufacturer cannot be held liable for any failure to observe the instructions contained in the operating manual. Likewise, any non-compliance with the operating guidelines may limit the manufacturer's warranty. Store this operating manual carefully for any subsequent owner.

The system is in compliance with all applicable safety regulations. Repairs may only be performed by specialists. Improperly performed repairs may result in significant danger to humans and the environment. Never connect a system that shows any damage (e.g. transport damage). If in doubt, consult customer service or your dealer.

This high-precision bolting system was manufactured and tested with great care and in accordance with the state of the art. Only select and highly durable materials have been used.

Thanks to this level of care, you are now in possession of a light and handy bolting tool which features a high-performance hydraulic power pack that is designed to complement this series of devices perfectly. However, high-performance devices also require a great deal of care and proper handling. This operating manual is intended to provide the assistance necessary in this regard.

Also important is that all personnel working with the system read this operating manual first and become familiar with the way the device and the power pack need to be handled.

This is also of importance when you lend the system to someone else, for instance - temporarily - to a different department in your company. Instructions to the operating personnel on how to handle the system properly are generally given by our trained specialists.

If several employees need to be instructed on how to handle or service the system, we can provide this service as well. We also offer you the option of having the power pack and the device including all accessories subjected to a thorough inspection once a year.

If the system is used with great frequency, this interval ought to be shortened. For more information, please refer to the enclosed service agreement offer.

If you need to send in your device or the power pack for repairs, please remember to complete the service questionnaire in full insofar as possible and include it in your shipment.

This is the only way for us to obtain a detailed idea of your application as well as the possible causes for the defect and, if applicable, take steps that will increase the reliability of the system further.

Our service department is furnished with all the specialty tools necessary and will utilise these tools in a prompt and reliable manner whenever the need for these tools arises. We, furthermore, subject the entire system to a function and performance test following every repair incident.

We, therefore, ask that you refrain from performing any modifications and repairs on the device, the accessories or the power pack yourself.

3. Information on safe working and accident prevention

3.1. Operation needs to be performed in observance of all applicable regulations on accident prevention, guidelines, safety rules, basic principles, characteristics and other publications related to operational health and safety issued by the German Social Accident Insurance Institution.

3.2. The device operates at a maximum pressure of 800 bar. The power pack is equipped with a safety valve which is set to the maximum permissible pressure. The setting of this valve must not be modified under any circumstances. In addition, the torque setting valve is limited to the maximum pressure of the power pack.

3.3. The electrical connection is subject to the provisions of the VDE guidelines. Only authorised electricians are allowed to perform inspections on the electrical components. Pull the power plug before performing any maintenance operations. When establishing a pneumatic connection, make sure not to exceed the maximum pressure setting of 6 bar which is set at the pressure reducer of the pressure regulation unit.

3.4. Make sure the hose couplings lock properly into place. Secure the hose couplings with a threaded ring to prevent them from becoming uncoupled by accident.

Attention!
Improperly coupled hoses may prevent the system from operating properly and cause accidents.

3.5. Ensure sufficient clearance for the hose connection. Never kink or twist high-pressure hoses and avoid dragging them across sharp edges. Do not expose to temperatures in excess of 70°C. Check hoses and couplings for damage on a regular basis. If detecting any leaks in the hoses,

shut down the system **immediately**. Also replace hoses, couplings, etc. **without delay** if they merely show damage on the exterior.

Strictly adhere to the safety rules applying to hydraulic hose lines. Protect the device against impact and blows and prevent it from falling down. Never remove the covers and safety devices found on the device. Secure the accessories to protect them from falling out or down.

3.6. Use the designated handles to transport and hold the device. Never hold the device by the reaction arm, any moving components or the hoses while it is in operation. Position the handle on the device in such a way that it is outside of the hazard area.

3.7. Make sure the device and the bolting joint as well as the reaction arm and the thrust bearing are connected in a secure and form-fitting manner. While working, keep monitoring the device and ensure its proper position. The device may only be supported in the area shown on pages 19/20 as there is otherwise a danger of the device sustaining damage.

3.8. Stay out of the area along the longitudinal axis of the bolting tool during work as there is otherwise a risk of components or bolting joints tearing, resulting in the device being flung away from the bolting.

3.9. Do not subject ratchet heads and accessories to torque levels greater than the torque permissible for these parts. The torque values permissible under normal operating conditions are embossed on the Plarad ratchet heads and the accessories.

3.10. In most cases, loosening boltings requires higher levels of torque than are necessary for tightening boltings. When faced with situations like these, you will find that standard sockets and accessories often do not provide the necessary stability. Also, the capacity of the device is oftentimes greater than the load capacity of the accessories. For these reasons, it is essential that you do not subject the accessories to torque levels that are greater than the maximum torque specified

for the accessories. If overloaded, the accessories may break, resulting in possible personal injury.

4. Operating principle

4.1. The hydraulic power pack is used to generate a hydraulic pressure which can be set using a pressure relief valve and read at a pressure gauge. This pressure is supplied to the bolting tool via high-pressure hoses (flow and return) and converted into torque by means of a system of levers and ratchets.

4.2. In addition to the pressure, the corresponding torque can also be read directly at the pressure gauge. This operating manual also includes a torque table.

4.3. The torque is transmitted to the bolting joint by means of an accessory inserted into the bolting tool (hexagonal socket, safety socket, Allen insert, etc.). The reaction force is absorbed by a suitable thrust bearing via a support device.

5. General information

5.1. Check the system for possible transport damage after receiving it. The transport risk is generally borne by the recipient rather than the supplier.

5.2. Since Hydro PLARAD is a system of great value, handling it properly is of utmost importance. Consequently, the system needs to be protected against impact and blows in order to avoid any damage or malfunctions. Furthermore, the connectors on hoses need to be sealed with the sealing caps after the hoses have been uncoupled in order to prevent dirt from penetrating the oil circuit. To avoid contamination it is also essential that you exercise great care when filling in oil.

Caution!
Hydraulic oil must not enter the soil, the groundwater or the sewage network.

5.3. If oil temperatures exceed 70°C, shut down

the power pack and allow it to cool down. If you cannot afford to let it cool down on account of your workload, you need to install an oil cooler.

5.4. Refer to the "Technical Data Sheet for Power Packs" for information on the electric motor's duty cycle and mode of operation at nominal output.

5.5. You should check the indicator accuracy of the pressure gauge at regular intervals by connecting a test pressure gauge.

5.6. Protect all moving parts, bearing points, etc. against corrosion and dirt.

To protect the included accessories against corrosion and dirt when they are not in use or stored, use suitable means to preserve these components.

5.7. To keep the friction in the thread and on the connecting surface of the bolting joint at a minimum, we recommend using a lubricant (e.g. Molykote, Gleitmo or similar agents).

5.8. If special parts are required in specific cases (reaction arms, safety sockets, Allen inserts or special ratchet heads), we ask that you consult with our technical department beforehand. We also ask that you do not make any alterations on the power pack, the device or the accessories as this will affect your warranty claims.

5.9. To prevent the power pack from sustaining any defects or failures, we recommend that you have our factory inspect your entire system at regular intervals. We also recommend that you enter into a service agreement with us.

5.10. Only the use of original PLARAD accessories and spare parts guarantees that your system will operate without fault.

6. Before putting the electric power pack into operation

6.1. Make absolutely sure that the available type of current and voltage match the specifications given on the type plate of the power pack.

6.2. ATTENTION: When transporting the system, you need to plug the oil filler opening using a sealing cap that provides a tight seal. In preparation of operation, this seal needs to be replaced with the ventilated cap hanging from the oil filler opening.

6.3. Check the oil level in the tank and refill oil as necessary. For the grade of the oil necessary, refer to the "Technical Data Sheet for Power Packs".

6.4. Establish the electrical connection. (follow VDE guidelines)

6.5. Connect the remote control cable to the power pack or the manual switch to the remote control cable if no permanent electrical connection is available.

6.6. Checking the rotational direction of the electric motor

6.6.1. The indicator lamp "Rotational direction" will come on for oil-immersed motors if the rotational direction of the motor is correct. If the indicator lamp does not light up, start by checking the voltage on all phases and reverse the polarity if necessary.

6.6.2. Set-up motors need to rotate clockwise (in the direction of the arrow). Verify by switching the motor on briefly. The indicator lamp "Rotational direction" needs to remain off in this case. Pull the power plug before performing any maintenance operations.

6.7. Connect the high-pressure hoses and make sure their couplings lock into place properly.

Secure the hose couplings with a threaded ring to prevent them from becoming uncoupled by accident.

Attention!

Improperly coupled hoses may prevent the system from operating properly and cause accidents.

7. Before putting the pneumatic power pack into operation

7.1. Make sure not to exceed the maximum pressure setting of 6 bar which is set at the pressure reducer of the pressure regulation unit.

7.2. ATTENTION: When transporting the system, you need to plug the oil filler opening using a sealing cap that provides a tight seal. In preparation of operation, this seal needs to be replaced with the ventilated cap hanging from the oil filler opening.

7.3. Check the oil level in the tank and refill oil as necessary. For the oil grade, see "Technical Data Sheet for Power Packs".

7.4. Pay attention to the oil level in the oiler

7.5. Connect the remote control cable to the power pack or the manual switch to the remote control cable if no permanent electrical connection is available.

7.6. Connect the high-pressure hoses and make sure their couplings lock into place properly. Secure the hose couplings with a threaded ring to prevent them from becoming uncoupled by accident.

Attention!

Improperly coupled hoses may prevent the system from operating properly and cause accidents.

8. Before putting the LT tool into operation

8.1. Insert matching accessories in the PLARAD-LT/TS (MS, TF) tool, attach the intermediate bushing on the shaft and secure.

Intermediate socket before attaching sufficiently lubricate. The loosening of screws connections accessory is inserted from the opposite side to the device. Each change must be taken to ensure that the bearings are supplied in the housing and in the lever sufficient with oil.

8.2. Attach the extent suitable PLARAD outriggers on the PLARAD-LT/TS (MS, MF) tool that the pawl can engage. Case of lateral support, the maximum permissible support lengths and torques must not be exceeded. Only PLARAD-supports and extension plates are used

8.3. After depending on the load of the tool - at regular intervals 20 hours of check whether all the joints and sliding surfaces are adequately lubricated inside the tool. Pay particular attention to good lubrication of the ball joint between the piston and lever. Purpose of lubrication nipples should be used on the casing head.

Recommendation for lubricants to be used:

Grease Tribol TR 3020/1000-2 or equivalent

for follower bearing, double ball joint, knuckle-ball joint, nut gearing and toothed driving.

Important notice: Insufficient lubrication may impair torque accuracy significantly. We recommend calibrating and inspecting the bolting system on an annual basis.

8.4.  High-pressure hose lines hitch and ensure proper engagement of the clutches. Hoses with threaded ring type, so that accidental disconnection is avoided.

Attention!
Improperly coupled hoses may prevent the system from operating properly and cause accidents.

8.5. We encourage you to use our specially designed for PLARAD-LT/TS (MS, MF) tools developed plug-in nuts with toothed drive. In comparison to standard nuts with square drive offer these a number of benefits to which you should not miss:

8.5.1. Safe work because device and nut form a compact unit.

8.5.2. No tilting as it might occur in the square of standard nuts.

8.5.3. Low height, resulting in fewer side forces by leverage.

8.5.4. Minimal backlash as the best form fit in the teeth.

8.5.3. Greater load capacity, since the vulnerability "square" is omitted. The standard square does not offer a guarantee to be able to transfer the corresponding high torque for larger key sizes, as well as a large bending moment on the device-square must be transmitted in addition to the torque at the long standard nuts.

8.5.4. Exact transmission of torque, because due to the reduced jamming and leverage the frictional forces in the wrenches are smaller.

8.5.5. The original PLARAD-LT/TS (MS, MF) - insert nuts but that also gentle on the screw driving.

8.5.6. The hexagonal faces of the nuts are running slightly arched so that they do not contribute linearly in the corners, but flat on the sides. Thus, the screw heads are evenly loaded and not damaged, and the nuts have far greater life than standard nuts.

9. Setting the torque

9.1. Connect the high-pressure hoses to the PLARAD bolting tool and make sure the quick-release couplings lock into place properly. Secure the hose couplings with a threaded ring to prevent them from becoming uncoupled by accident. Make sure the hoses are clear and untangled.

9.2. Press and hold the button "On-Forward" on the

remote control until setup is complete.

9.3. Turn the adjusting valve (pressure relief valve on the power pack) to set the desired torque and read the torque on the pressure gauge. If the pressure gauge does not include a torque scale, you need to use the included torque table to set the torque.

Important notice: Check if valid torque tables are available for your device.

The number of the correct torque table is specified on the "Technical Data Sheet Hydro PLARAD Bolting Tool". Compare the torque table with the torque scale pasted on the pressure gauge. If you have any questions, consult our technical department.

9.4. After setting the desired torque level, press the "Off" button on the power pack (or the remote control). The electric motor switches off.

9.5. When setting the torque, make absolutely sure not to exceed the maximum torque level permitted for the ratchet heads and the accessories. The permissible torque is embossed on the ratchet heads and accessories.

10. Mode of operation

10.1. Pre-tighten the bolt you need to tension by hand.

10.2. Position the PLARAD bolting tool on top of the bolting joint in such a way that the bolt head/the nut is captured in its entirety by the socket/hexagonal socket. If this is not possible, you may only subject the accessories to reduced torque or you need to use a special hexagonal socket/socket or different accessories.

10.3. Make sure the high-pressure hoses are clear and untangled and that there is enough clearance for the hose connection. Never kink the hoses

10.4. Pivot the PLARAD bolting tool to a suitable thrust bearing. Make sure the device is sufficiently supported. As far as possible, prevent the device/accessories from canting while on top of the

bolting joint. If significant canting is unavoidable due to the way the device/accessories is/are supported, you need to reduce the maximum torque for safety reasons. If you have any questions, consult our technical department.

10.5. Press the "On-Forward" button to extend the cylinder housed inside the cylinder of the device until it reaches its end position, effecting a rotational movement of the hexagonal socket, socket or other accessories.

10.6. The piston will retract automatically when you release the button.

10.7. Keep pressing the button until you can no longer detect a rotational movement. You will then have reached the previously set torque.

10.8. Once the torque indicator (pressure gauge) has reset completely, press the "On-Forward" button on the power pack again and run the unit up to the set pressure. Meanwhile, monitor the torque indicator and the PLARAD bolting tool until the unit has come to a standstill.

10.9. When finished using the bolting tool, press the "Off" button.

The power pack switches off. Before uncoupling the hoses, press the "Off" button several times.

10.10. On power packs equipped with a separately controlled forward and return stroke:

Press and hold the "Forward" button - the piston extends, press and hold the "Back" button - the piston retracts

10.11 The power packs are usually equipped with an automatic cut-off device that is designed to reduce the heating of the oil. If the remote control is not actuated for approx. 20 seconds, the power pack will switch off automatically. You can resume operation immediately by pressing the "On-Forward" button.

10.12. Since loosening boltings often requires much higher torque levels than are necessary for tightening boltings, the capacity of ratchet heads,

standard sockets and accessories is, in many cases, insufficient to break a bolt loose. To overcome this problem, we recommend that you use reinforced ratchet heads, ring spanner inserts, sockets and accessories. Our technical department will be happy to assist you if you require any help in this regard.

11. Avoiding and correcting faults

Strictly observe the following to avoid defects and faults:

11.1. Power pack

11.1.1. Establish the electrical connection as required by applicable codes (see Technical Data Sheet).

11.1.2. Keep the tank sufficiently filled with oil of the proper grade (see Technical Data Sheet). Only fill in oil that is clean and fresh.

11.1.3. Protect valves and pressure gauge against impact and blows.

11.1.4. Never exceed the maximum permissible pressure. Do not alter the fixed settings of the pressure valves.

11.1.4. Switch off the power pack and allow it to cool down if the oil temperature rises above 70°C. Install an oil cooler if necessary.

11.1.5. Check hoses and couplings for impurities. Check for damage on a regular basis.

11.2. Device

11.2.1. Use only original PLARAD accessories.

11.2.2. Supply oil / grease to the lubricating points as specified in the operating manual.

11.2.3. Use only original PLARAD reaction arms. Do not extend the reaction arms. If the resting arm provides support from an extremely lateral position, the applied torque needs to be reduced. If you have any questions, consult our technical department.

11.2.4. Never exceed the permissible torque (see Technical Data Sheet and type plate).

11.2.5. Set the torque following the enclosed table / torque scale pasted onto the pressure gauge. Do not exceed the maximum pressure specified in the torque table even if the power pack allows for it.

11.2.6. Never kink hoses and couplings. Keep couplings clean.

11.2.7. Do not modify the device or the accessories in any way. Never detach any sealed fasteners.

11.2.8. When pressurising the PLARAD bolting tool, you need to ensure that the hoses are sealed tightly.

If failing to couple the return stroke hose, you run the risk of the hose or another component bursting on account of the excess pressure to which it/they are subjected.

To eliminate this risk, the hose connectors are equipped with an excess pressure safeguard. If the pressure reaches excess levels, this safeguard opens on the side of the piston rod to allow the backed-up oil to escape without danger.

Attention!

The setting of this excess pressure safeguard must not be altered (accident hazard).

Disruptions of operation which you can rectify yourself

Complaint	Possible cause	Remedy
Motor not starting up	motor circuit breaker has tripped Indicator lamp "Fault" lights up red phase failure	switch back on by pressing the red plastic cap check the electrical connection
Motor circuit breaker trips repeatedly	electrical connection not established properly wrong type of current incorrect voltage motor circuit breaker not set correctly voltage deviation in the mains supply rated hydraulic pressure exceeded or cut-off pressure set too high duty cycle of the power pack automatic cut-off device has failed	check electrical connection check the electrical connection check the electrical connection set the motor circuit breaker to the correct value; for the set value, see the Technical Data Sheet for Power Packs provide for proper mains voltage, check the connection type; see Technical Data Sheet for Power Packs notify customer service let the power pack cool off or install an oil cooler notify customer service
No hydraulic pressure in the power pack	hydraulic pressure is not indicated due to a defect in the pressure gauge pump defective rotational direction of the motor incorrect oil level too low	connect a second pressure gauge, press the "On-Forward" button, adjust the torque setting valve, and determine the change in pressure on both pressure gauges. Replace the pressure gauge on the power pack if it is experiencing a defect. notify customer service check the rotational direction of the motor (see 4.6) fill in oil (see 4.3)

Complaint	Possible cause	Remedy
<p>No hydraulic pressure in the power pack</p>	<p>torque setting valve set incorrectly or defective</p> <p>pressure valves or shut-off valves inside the power pack set incorrectly or defective</p> <p>solenoid valves fail to switch on/off</p>	<p>set torque setting valve to a higher pressure or replace it if defective</p> <p>notify customer service</p> <p>the solenoid valves are equipped with a manual override. If pressure is indicated during manual actuation, you need to check the electrical connection (24V). If no pressure is indicated during manual actuation, you need to notify customer service</p>
<p>No hydraulic pressure in the device</p> <p>Reaction foot can no longer be retracted (in K tools), device leaking, oil escaping</p>	<p>hose connection between power pack and device not in order</p> <p>hose connections leaking</p> <p>device leaking, oil escaping</p> <p>excess pressure safeguard broken inside the hose connecting plate</p>	<p>connect hoses properly and verify that the hose couplings have snapped into place correctly. Secure hose couplings with a threaded ring.</p> <p>replace hose lines. Screw in new hoses with an R 1/4" or NPT 1/4" thread applying approx. 40 Nm of torque.</p> <p>notify customer service.</p> <p>see 6.6</p>

Notify customer service about any other types of failure.
Report, in particular, any faults occurring in the ratchet system of the device.

12. Guidelines on positioning and arranging the reaction arm

Image 1: Optimum support scenarios:

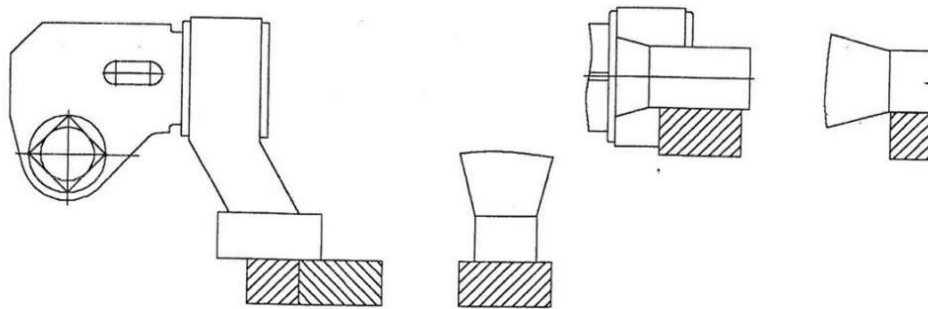

Make sure the reaction arm rests fully against the surface!

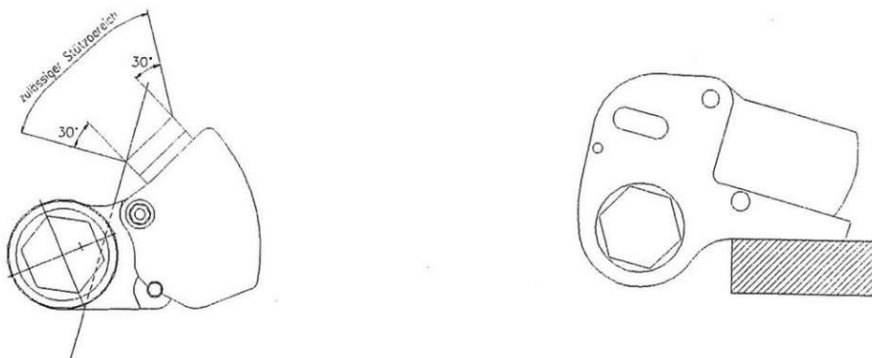
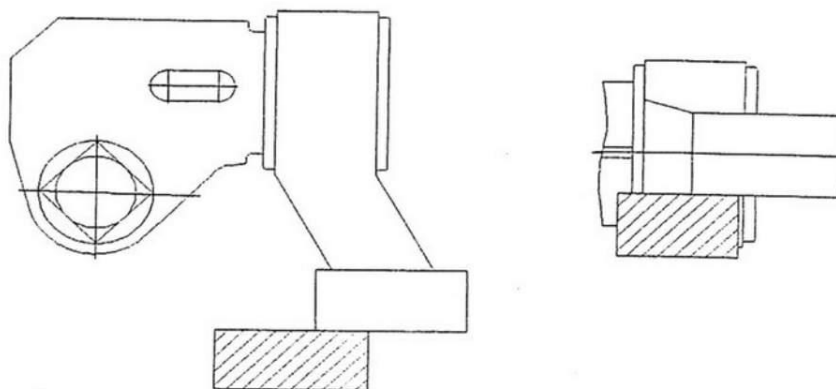
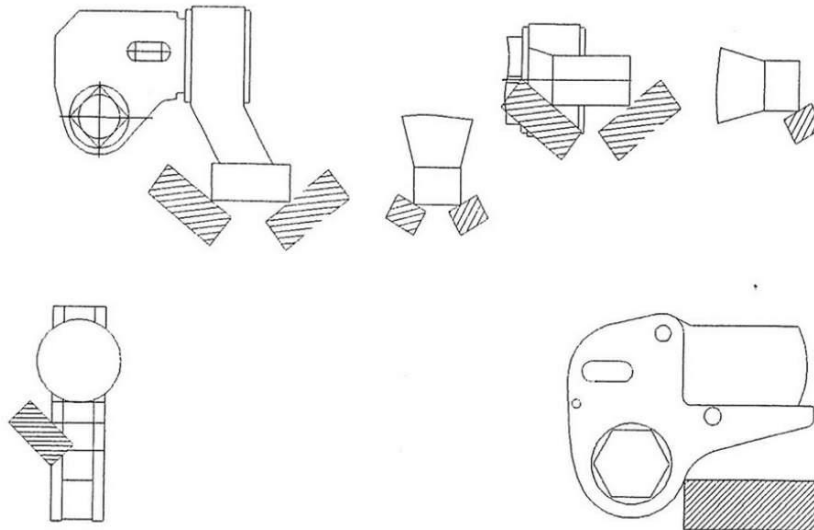

Image 2: Avoid if possible:



The generated transversal and bending forces become high enough to exert strain on the device and the device accessories.

Image 3: Impermissible support scenarios:



If the reaction arm rests against a slanted surface only at certain points, a strong force may slip the reaction arm off the device and possibly result in breakage of the device accessories.

Attention - accident hazard!

4. General

These guidelines apply to the position of the reaction arm both when at device level (I) and pivoted towards the bolting axis by 30°, 60° and 90° (II-IV).

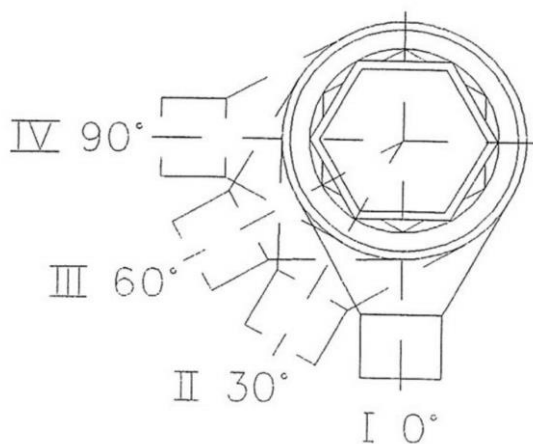

Notice:

Slip the reaction arm on only as shown in image 1!

The retaining ring fitted inside the reaction arm must not be removed!

Reaction arm and reaction foot may not be altered beyond the specified permissible dimensions!

If necessary, consult with our technical department to discuss the situation and a detailed graphical representation of the bolting application.



... a successful
connection!

Maschinenfabrik Wagner GmbH & Co. KG
Birrenbachshöhe · 53804 Much · Germany

Tel. national: (02245) 62-0
Fax national: (02245) 62-66
Phone international: +49 (0)2245 62-10
Fax international: +49 (0)2245 62-22

info@plarad.com · www.plarad.com

Reproduction and copying of this volume, in whole or in part,
is permissible only with express written permission. Subject to
amendment. We take no responsibility for printing
errors or inaccurate information.
Last update: 11/2013

D50-000-1-02200

2_BA_LT_GBR_1.0_69792