

# Operating manual Tensioner PSE/PSEF



PSE



PSEF



# Contents

<b>1. User instructions</b>	<b>3</b>
<b>2. Product safety</b>	<b>4</b>
2.1. Training of personnel	5
2.2. Depiction of safety instructions	5
2.3. Symbols on the machine	6
2.4. Personal protective equipment (PPE)	6
<b>3. Description of the machine</b>	<b>7</b>
3.1. Illustration and identification	7
3.2. Intended use	7
3.3. Foreseeable misuse	8
3.4. Design and components of the machine	8
3.5. Description of operation	8
3.6. Workstations of the operating personnel	8
3.7. Hazard areas	8
3.8. Warning devices	10
3.9. Technical specifications	10
<b>4. Transport</b>	<b>10</b>
4.1. Transporting machine and machine parts	10
<b>5. Installation and start-up</b>	<b>11</b>
5.1. Design and installation	11
5.2. Initial operation	11
<b>6. Operation</b>	<b>12</b>
6.1. Operating the machine	12
<b>7. Maintenance and repairs</b>	<b>17</b>
7.1. Cleaning the machine	17
7.2. Auxiliary and operating materials	18
7.3. Maintenance schedule	18
7.4. Fault finding and troubleshooting	20
7.5. Spare and wear parts	21
<b>8. Shutdown, storage and disposal</b>	<b>21</b>
8.1. Shutdown	21
8.2. Storage conditions	21
8.3. Disposal	21

# 1. User instructions

## Purpose of the document

This operating manual is intended to familiarise the owner/operator with the tensioner and provide information on its possible applications and proper use. The operating manual contains important information that allows the owner/operator to use the tensioner in a safe, proper and efficient manner. Observing this information helps avoid risks, minimise repair costs and downtimes and increase the reliability and service life of the machine.

## Information on precautions to be taken by the owner:

- Entrust only personnel who have the necessary qualification with tasks involving the tensioner.
- Clearly define the responsibilities and accountabilities of the operating and maintenance personnel.
- Supplement the operating manual by rules arising from national regulations regarding occupational health and safety and the environment (e.g. work organisation).
- Order and occasionally verify compliance with the operating manual and its supplements. Keep a copy of the operating manual at the place where the machine is used at all times!
- Maintain the tensioner's proper technical condition and refrain from using the tensioner if its proper technical condition could not be established.

Apart from the operating manual, the mandatory accident prevention regulations applicable in the country and the place where the machine is used must be observed. In addition, all recognised technical rules

devised to ensure safe and professional work need to be observed.

## Target groups

- a) The owner as the superior legal entity is responsible for the intended use of the tensioner and the training and use of the authorised personnel. He defines the mandatory responsibilities and authorities of the authorised personnel working at his company.
- b) A **specialist** is defined as a person who is capable of assessing the tasks assigned to him and of detecting any possible risks on account of his professional training, expertise and experience. This person is also familiar with all applicable regulations. Only trained experts or such personnel who have been selected and found capable by the owner are qualified to work with the machine.
- c) A **trained/instructed person** is a person who has been instructed and, if necessary, trained in the assigned tasks and the possible risks involved with improper conduct. This person has also been informed about the necessary safety devices and safety measures. Personnel to be qualified, trained, instructed or undergoing general job training may only act under the constant supervision of an experienced person.

## Liability and warranty

All information and instructions provided in this operating manual are based on our previous experience and findings and given to the best of our knowledge. The original version of this operating manual was prepared in German and reviewed by us for technical accuracy. The translation into the appropriate national/contractual language was prepared by a certified translation agency.

This operating manual was compiled with the greatest level care. If you, however, detect any portions that are incomplete and/or incorrect, please notify us in writing. Your suggested improvements help us create an operating manual that is more user-friendly.

### Re-orders and copyright

Additional copies of this operating manual are available from Maschinenfabrik Wagner GmbH under the address given below. Please note that all re-orders are subject to a charge. All rights expressly reserved. Copying or disclosing the content of this operating manual to third parties - in which form whatsoever - is not permitted without our written approval.

## 2. Product safety

The prerequisite for the safety-compliant handling and trouble-free operation of the tensioner is familiarity with the basic safety instructions.

### Organisational measures

- a) The operating manual must be kept in legible condition and readily available at the place where the tensioner is used!
- b) The operating manual needs to be supplemented by rules that incorporate the specific conditions present on site (e.g. duty of supervision and obligation to notify the authorities, work organisation, operational procedures, assigned personnel, fire alarm and fire fighting options, and the operation of fire extinguishers).
- c) The operating manual also needs to be supplemented by mandatory local regulations regarding accident prevent and environmental protection (e.g. handling hazardous materials, disposal of auxiliary and/or operating

materials, and the provision/requirement to wear personal protective equipment)!

- d) Personnel must be ordered to observe the operating manual!
- e) Personnel are required to notify the owner or his agent of any defects or hazards they have detected.

### Proper technical condition

- a) Keep all safety and hazard warnings placed on/applied to the tensioner in complete and legible condition!
- b) Do not introduce any modifications, attachments and conversions to the machine that may impair safety without consulting/coordinating with us! This also applies to the installation and getting of safety devices and valves as well as any welding on load-bearing parts.

**Substantial changes to the tensioner may render the EC Declaration of Conformity invalid!**



- c) Observe all intervals for recurring checks/inspections and replacements of vital safety components that are required (by law) or set out in the operating manual!
- d) All spare parts used must correspond to the technical requirements stipulated by the manufacturer. This requirement is satisfied by the use of original spare parts.
- e) When having maintenance work performed independently, make sure to provide the appropriate workshop equipment necessary to complete the work!
- f) Apart from this operating manual, all information and instructions provided in the supplier documentations need to be observed (see appendix)!

## 2.1. Training of personnel

- a) Selection and qualification of personnel  
Only reliable personnel may be entrusted with work on/with the tensioner. Observe the minimum age requirements stipulated by law!
- b) Use only trained or, at the least, instructed personnel! Order and, on occasion, verify that only authorised personnel are used to operate the machine!
- c) Clearly define the responsibilities and accountabilities of the personnel with regard to operation, set-up, maintenance and repairs!
- d) Do not allow personnel undergoing qualification, instructions or job training to operate the tensioner unless acting under the supervision of an experienced person
- e) Work on hydraulic/pneumatic equipment must be restricted to experienced and qualified experts!

## 2.2. Depiction of safety instructions

The operating manual uses the following illustrations to depict safety instructions:

**Danger:**  
**Specifications / instructions and warnings intended to prevent personal injury**



**Attention:**  
**Particular specifications / instructions and warnings intended to prevent property damage**



**Notice:**  
**Particular specifications / instructions and warnings regarding the proper and efficient use of the machine**



### 2.3. Symbols on the machine

Observe operating manual



Wear protective footwear



Stay out of the tensioner's axial force direction



The axis of the bolt must be at a right angle to the supporting surface



### 2.4. Personal protective equipment (PPE)

The personal protective equipment (PPE) described below must be provided by the owner and used by the responsible operating personnel while handling the machine.

Use gloves



Use protective footwear



Wear hearing protection



Wear protective headgear



### 3. Description of the machine

#### 3.1. Illustration and identification



Sample picture

#### Identification of the machine

The position of the identification is found in the illustration above:

The following specifications are given on the tensioner:

- Company name including corporate headquarters
- Type designation:
- Serial no.:
- Maximum operating pressure
- Maximum tensile force
- Test pressure
- Year of manufacture:
- CE mark

#### 3.2. Intended use

Within the limits of supply, the tensioner has been manufactured in accordance with the state of the art and the recognised technical safety rules. Regardless, the use of the tensioner involves certain risks to the life and limb of the user or third parties as well as the risk of damage to the tensioner and other material assets.

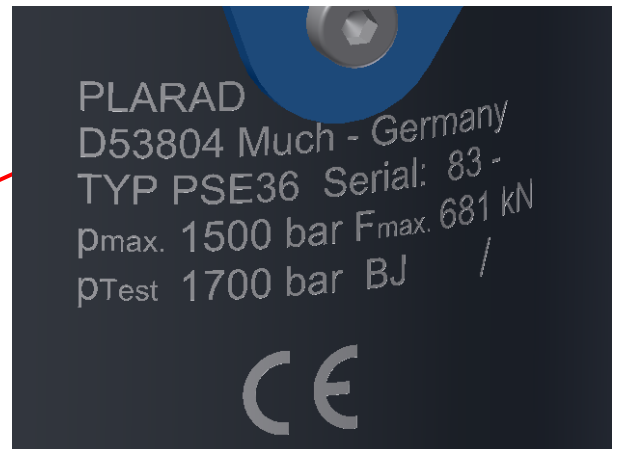

The tensioner may only be used if in proper technical condition, in accordance with its intended use, with an awareness of safety and the risks involved and in observance of the operating manual! It is of particular

importance in this regard to have any faults that may affect safety eliminated without delay! The tensioner is designed only for the purpose described in chapter 4.5 "Description of operation". Any use deviating from or exceeding the scope of intended use is considered to be improper. The manufacturer/supplier **cannot** be held liable for any damage resulting from such improper use. The risk lies solely with the owner.

**Intended use also includes observing the operating manual and the conditions specified for inspections and maintenance.**

### 3.3. Foreseeable misuse

The tensioner may only be used at operating pressure levels that do not exceed the permissible maximum.

Prior to tensioning, make sure not to subject any of the components to a load that exceeds their maximum load-bearing capacity.

The thread engagement between the bolt to be tensioned and the draw bolt / draw nut usually needs to be at least 1xD.

The maximum permissible stroke distance of the tensioner must be observed.

Allow only Maschinenfabrik Wagner or bodies authorised by Maschinenfabrik Wagner to install, readjust, modify, expand and repair the tensioner. Use the tensioner only as described in the operating manual. Operating the unit in a safe and reliable manner will otherwise not be possible. Unauthorised modifications may lead to unexpected hazards.

The safety of the operator and the trouble-free operation of the unit are only guaranteed if you use original PLARAD components. This applies both to device components and spare parts.

If different components are used, Maschinenfabrik Wagner cannot guarantee safe and reliable operation.

### 3.4. Design and components of the machine

The main components of the tensioner are two cylindrical tubes housing two pistons which use hydraulically applied pressure to pull at a bolt while propping themselves up on a supporting surface.

### 3.5. Description of operation

The tensioner is used to hydraulically pull at a bolt in axial direction .

The tensioner may only be supported on a surface that is vertical in relation to the axis of the bolt

### 3.6. Workstations of the operating personnel

**Anyone else besides the operating personnel should stay out of the bolting area.**

**The worker must stay out of the tensioner's operating direction.**

**If possible, stand back a few meters from the pressurised components while tensioning is in progress. The required safety measures need to be observed at all times.** Workstations of the operating personnel

### 3.7. Hazard areas

Efficient collaboration and exact coordination of their activities are required for several people to work on the machine.



**Stay out of the pressurised tensioner's direction of pull.**

#### Hydraulics

- a) Work on this equipment must be restricted to personnel who have the specific expertise and experience necessary!
- b) All lines, hoses, and bolted connection must be regularly checked for leaks and visible exterior damage! Remove any damage immediately! Oil spurting out from the machine may cause injury and fire.
- c) Make sure that all hydraulic elements used (hoses, manifolds, pressure gauges, etc.) are designed to withstand the maximum operating pressure of the tensioner.



- d) Before performing any repairs, depressurise the system sections to be opened and the pressure lines in
- e) Make sure to lay and install hydraulic lines in the proper manner! Do not confuse the connections. The valves, length and quality of the hose lines must satisfy the requirements.

**Noise**

Wear the required personal protective equipment (hearing protection)!

**Oil, greases and other chemical substances**

Auxiliary and operating materials must be used and disposed of as specified by the manufacturers of these substances

### 3.8. Warning devices

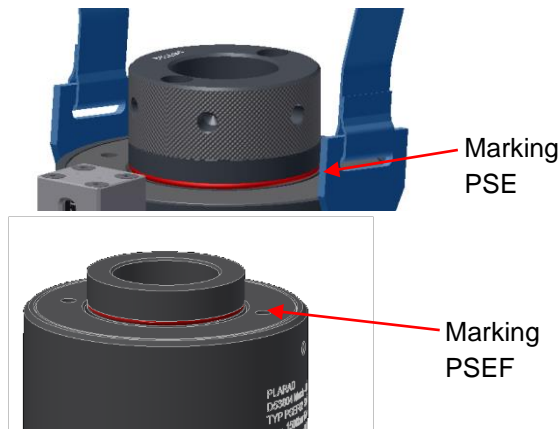

A red marking on the draw bolt indicates that the maximum stroke distance has been reached. As soon as the marking is visible, the nut needs to be added, and the tensioning process needs to be repeated after the draw bolt has been retracted.

The set pressure can be checked regularly on the power pack / the hand lever pump.

If the tensioner is equipped with a cycle counter, the operator can use this indicator to read the number of tensioning cycles already completed.

We recommend to change the draw bolt whenever the tensioner has reached the maximum permissible cycle count (see technical drawing).

### 3.9. Technical specifications

#### Dimensions, weight:

Refer to the attached drawing and the cover sheet for the technical specifications.

#### Supply, interfaces, and connections:

The maximum permissible operating pressure is given in the attached drawing.

#### Ambient conditions:

Temperature -20°C to 70°C

## 4. Transport

### 4.1. Transporting machine and machine parts

The tensioner must be depressurised prior to transport.

The hydraulic hose must be removed.

Transport may only be performed by personnel capable of performing the necessary work on account of their expertise and experience in the field of transport.



The machine and larger components must be carefully attached to and secured by lifting gear. Use only lifting gear and slings of sufficient load-bearing capacity that are suitable and in proper technical condition. Do not stay or work under suspended loads!



Entrust only experienced personnel with attaching loads!



Attach / remove transport securing devices to and from the machine parts.



#### Unpacking

The packaging material should be used several times if possible or disposed of in accordance with the regulations applicable at the site of operation.

#### Handling

The tensioner should only be attached to and transported while suspended from the designated attachment points.



Always wear safety shoes and protective gloves.



## 5. Installation and start-up

Set up the machine on a stable, low-vibration surface in a dry location.

The surface supporting the tensioner must be at a right angle to the axis of the bolt.

The machine must be easily accessible at all times, allowing the operator to handle the machine in a safe and comfortable manner. Refer to the technical specifications for the dimensions and conditions to be met by the required space.

The machine may only be operated in an environment that offers the type of lighting conditions that are required by the applicable ergonomics regulations.

### 5.1. Design and installation

Tensioner, pressure and power pack/hand pump need to be depressurised before they can be installed.

Make sure the hydraulic hose is routed in a safe and proper manner. Possible danger to the hose caused by dragging it over sharp edges, driving over it with vehicles, subjecting it to loads exerted by heavy objects, etc. must be avoided.

Coupling, nipple and hose must be checked prior to installation. Clean coupling and nipple if necessary.



Coupling and nipple are connected by pulling back the coupling ring. When released, the ring must engage with an audible and visible click. Once the coupling ring has locked into place, you need to screw the retaining ring onto the hose coupling.



The components need to be depressurised before they can be removed.



Make sure the media connections do not show any leakage following installation. If detecting a leak, you need to depressurise the system immediately!

### 5.2. Initial operation

Before putting the machine into operation, the owner is required to perform a visual inspection in order to ensure that there are no unauthorised persons in the vicinity of the machine.



Set the desired pressure on the power pack before connecting the tensioner. Observe the maximum operating pressure!



## 6. Operation

### 6.1. Operating the machine

Before using the tensioner, make sure that no one can be put at risk during the tensioning process! Perform a visual check of the tensioner to check for defects.

Stay out of the tensioner's direction of pull!

Always wear protective clothing when using the tensioner.



#### 6.1.1. PSE

Make sure the thread engagement between bolt and draw bolt is at least  $1 \times D$ .

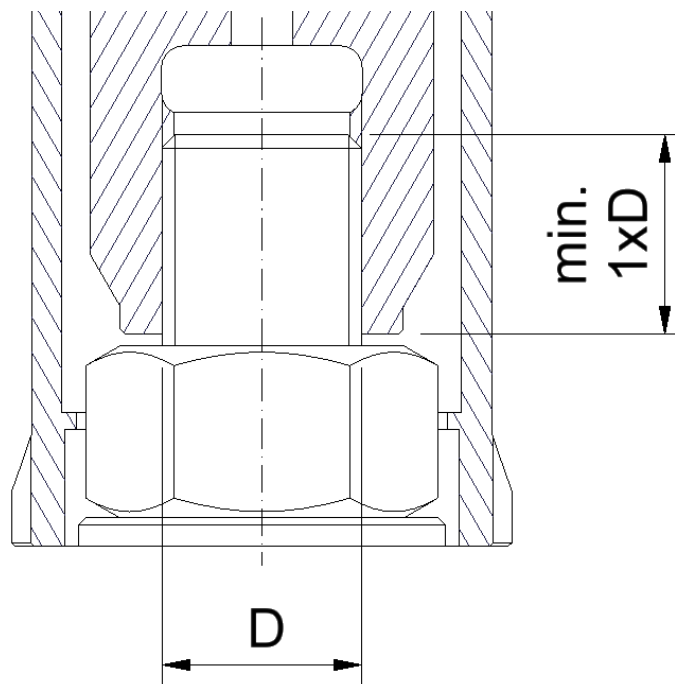

Observe the maximum operating pressure permissible for the bolting application at hand.

Observe the permissible stroke distance. Exceeding the permissible stroke distance may result in leakage and damage to the tensioner.

Make sure the draw bolt is at its initial position prior to each tensioning process.

### 6.1.1.1 Tensioning process PSE

Clean the surface supporting the tensioner. Dirt, paint residue, etc. may lead to a more intense setting effect following the tensioning process.

Check if the supporting surface is vertical in relation to the axis of the bolt.

Clean, inspect and lubricate/oil the thread.

Position the tensioner carefully to prevent damage to the threads. Proceed by screwing on the tensioner until the reaction arm rests on the supporting surface.

For systems without a spring-loaded rotating sleeve:

When screwing on the tensioner, make sure the hexagon of the rotating sleeve lines up with the hexagon nut.

Check to verify that all hose connections are properly connected.

When the tensioner is pressurised, the bolt is elongated, and the draw bolt extends.

Pay attention to the maximum stroke distance! If reaching the maximum stroke distance, switch off the power pack immediately! Add the nut, relieve the tensioner, and repeat the tensioning process.

Add the nut upon reaching the desired pre-tensioning force.

To do so, use either the included pin (round nut or rotating sleeve with drill holes) or the gearbox.

The gearbox is only designed for the purpose of adding the nut. Please observe the maximum permissible torque (40Nm or 80Nm).



The system can be depressurised after the nut has been added.

**6.1.2. PSEF**

Make sure the thread engagement between bolt and draw bolt is at least  $0,8xD$ .

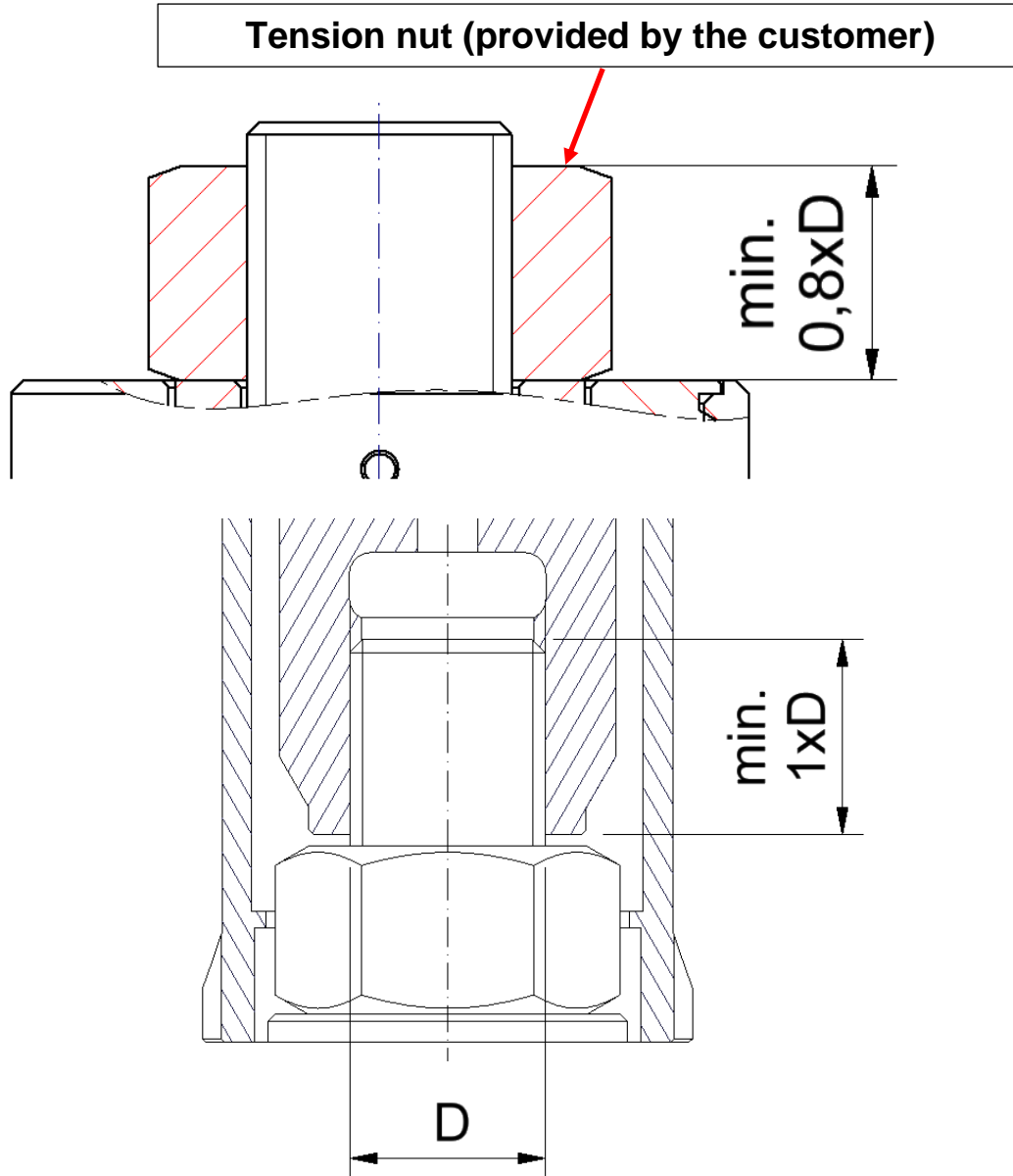

Observe the maximum operating pressure permissible for the bolting application at hand.

Observe the permissible stroke distance. Exceeding the permissible stroke distance may result in leakage and damage to the tensioner.

Make sure the draw bolt is at its initial position prior to each tensioning process.

### 6.1.2.1 Tensioning process PSEF

Clean the surface supporting the tensioner.  
Check if the supporting surface is vertical in relation to the axis of the bolt.

Clean, inspect and lubricate/oil the thread.

Position the tensioner carefully to prevent damage to the threads. Proceed by screwing on the tensioner until the tension nut rests on the supporting surface.

For systems without a spring-loaded rotating sleeve:

When screwing on the tensioner, make sure the hexagon of the rotating sleeve lines up with the hexagon nut.

Check to verify that all hose connections are properly connected.

When the tensioner is pressurised, the bolt is elongated, and the draw bolt extends. Pay attention to the maximum stroke distance! If reaching the maximum stroke distance, switch off the power pack immediately! Add the nut, relieve the tensioner, and repeat the tensioning process.

Add the nut upon reaching the desired pre-tensioning force.

To do so, use either the included pin (round nut or rotating sleeve with drill holes) or the gearbox.

The gearbox is only designed for the purpose of adding the nut. Please observe the maximum permissible torque (40Nm or 80Nm).



The system can be depressurised after the nut has been added.

### 6.2. Setting behaviour:

To offset any setting effects, we recommend that you repeat the tensioning process at least twice.

Oftentimes, compensation can already be achieved through an increase in the calculated pre-tensioning force - by multiplying this force with the appropriate factor.

Piston return mechanism:

The piston in systems equipped with an automatic piston return mechanism moves back to its initial position after the pressure has been cut off. All other systems require that the piston be returned to its initial position by screwing on the draw nut.

In both cases, the hydraulic hose needs to remain connected to allow the oil to be pressed back from the cylinder into the tank. Do not switch off the connected power pack immediately after the tensioning process is complete. Depending on the power pack used, the system may remain pressurised after being switched off!

### 6.3. Loosening process:

Important for the loosening process is that the tensioner is not screwed onto the bolt all the way. There should be a minimum play of approx. 1-2 mm between reaction arm and supporting surface (the distance may have to be greater for bolts that are particularly long). The nut can be released after the hydraulic pressure has been applied. When doing so, make sure not to screw the nut all the way up to the draw bolt / draw nut.

If the tensioner can no longer be moved after the nut has been released, the original elongation of the bolt was greater than the play present between reaction arm and supporting surface during the loosening process.

It will be necessary, in this case, to tighten the bolt again.

Repeat the loosening process afterwards, providing for greater play between reaction arm and supporting surface.



## 7. Maintenance and repairs

If the removal of safety devices is required, the safety devices need to be refitted and checked immediately following the conclusion of maintenance or repairs.



Cleaning also entails keeping the floor clean, clearing packaging materials etc., and preventing tools from lying about.

Refrain from using compressed air to clean the machine. The machine may, otherwise, experience increased wear and a greater number of faults. Use only soft cleaning cloths for cleaning



Comply with the specified setting up, service and inspection tasks and schedules including information for replacement of parts/subassemblies! Observe all intervals applicable in this regard! These activities may only be performed by specially trained and authorised experts.



Remove any oil, fuel and care products from the machine and, in particular, the connectors and bolted connections before performing maintenance/repairs! Do not use any abrasive cleaning agents! Use lint-free cleaning cloths!



To ensure safety during work on the tensioner, the hydraulic hose needs to be disconnected! Pressurised systems need to be relieved!



When finished cleaning, check all supply lines for leaks, loose connections, chafe marks and damage! Correct any detected defects immediately!



Always firmly re-tighten bolted connections that have previously been loosened for the purpose of maintenance and repairs!



Also follow the instructions provided in the supplier documentation.



Performing regular maintenance and inspections on the machine is of great importance. This minimises the occurrence of faults and increases operational reliability.



Auxiliary and operating materials as well as cleaning agents and replacement parts need to be disposed of in a safe and environmentally compliant manner! Follow the instructions of the manufacturer when dealing with hazardous materials!



### 7.1. Cleaning the machine

To ensure safety during work on the tensioner, the hydraulic hose needs to be disconnected! Pressurised systems need to be relieved!



The machine needs to be constantly kept clean while operation is in progress.



## 7.2. Auxiliary and operating materials



When handling auxiliary and operating materials (e.g. oils, greases and other chemical substances), observe the safety instructions applicable to the product you are using! The information provided in the manufacturer's material safety data sheets must be observed!

Operating material used in the tensioner:

Hydraulic oil HVLP DIN 51524-3

## 7.3. Maintenance schedule

Work on the technical equipment of the machine (hydraulic system) may only be performed by qualified experts!



The spare and wear parts listed in the technical documentation must be replaced immediately if damaged.



**Maintenance overview**

Throughout the useful life of the machine, it is necessary to perform a variety of maintenance steps and inspections. The intervals at which these tasks need to be carried out are listed in the maintenance schedule. It is, furthermore, necessary to observe the maintenance intervals applicable

to the purchased parts specified in the appendix.

The maintenance intervals need to be shortened if the machine is used in particularly harsh and demanding work environments.

<b>Process</b> P = Check                      E = Adjust R = Clean                        N = Re-tighten S = Lubricate                  A = Replace		<b>Interval</b> T = daily                        H = semi-annually W = weekly                      J = annually M = monthly		
Component/check	Type of check	Process	Interval	Comments
Draw bolt		A		Replacement after recommended permissible cycle count has been reached. See technical drawing of the tensioner
Warning pictograms Check for damage and completeness	Visual inspection	P	T	
Hydraulic equipment: Check piping/hose lines for: Firm seating, damage, proper marking	Visual inspection	P	T	
General condition of the tensioner: Cycle counter check, carrying handle, rotating sleeve, gearbox	Visual inspection	P	T	
Seals		A	4 years	Replace seals every 4 years regardless of their extent of usage

All maintenance operations should only be performed by trained personnel.

**7.4. Fault finding and troubleshooting**

<b>Fault</b>	<b>Cause</b>	<b>Correction</b>
Operating pressure is not being built up (If no leak is detectable, the fault lies with the power pack / pump)	Component defective Seals worn Stroke limiter has tripped	Service by manufacturer Service by manufacturer Add nut and start another tensioning process
Rotating sleeve not springing back	Reaction arm heavily soiled	Dismantle and clean
Gearbox cannot be turned	Reaction arm heavily soiled Gearbox damaged by excess torque	Dismantle and clean  Service by manufacturer
Piston return incomplete	Hydraulic hose removed too fast Power pack cut off too fast Power pack not relieved Springs defective	Connect hydraulic hose Switch power pack back on Flip lever to relieve Service by manufacturer
Hydraulic hose cannot be connected	System is pressurised	Release pressure
Tensioner jammed following the loosening process	The bolt is still under tension	Re-tighten the bolt, add the nut again, and depressurise the tensioner. Slightly turn back the draw nut to increase the gap between the reaction arm and supporting surface. Repeat the loosening process

## 7.5. Spare and wear parts

All spare parts used must correspond to the technical requirements stipulated by us. This requirement is satisfied by the use of original spare parts. We only grant a warranty on the original spare parts we supply. The installation and/or use of spare parts not supplied by us may have a negative impact on the specified design properties, thereby impairing active and/or passive safety. We do not assume any liability and warranty for any damage that can be attributed to the use of spare parts / accessories other than those supplied by us.

We require the following information to process your order in an efficient and expedient manner:

1. Client
2. Machine identification data
3. Designation of the desired spare part
4. Desired units
5. Desired shipping method

You will find the address and all other necessary information on the cover sheet.

## 8. Shutdown, storage and disposal

### 8.1. Shutdown

Make sure to avoid leaks after disconnecting the media supply connections which may endanger people and/or the environment! 

Auxiliary and operating materials as well as cleaning agents and replacement parts need to be disposed of in a safe and environmentally compliant manner!

Follow the instructions of the manufacturer when dealing with hazardous materials! 

Observe the following:

1. Depressurise the hydraulic systems completely!
2. Use special care when removing springs or other parts under mechanical tension to prevent the mechanical energy stored in these parts from causing injury.
3. It is, furthermore, necessary to observe the maintenance intervals applicable to the purchased parts specified in the appendix.

### 8.2. Storage conditions

Store the tensioner in such a way that any possible damage can be excluded. 

Store the tensioner together with all of its individual parts as essential parts may otherwise be missing when the machine is put back into operation. 

#### Storage

Take the following aspects into account when storing the tensioner:

- Protection of parts susceptible to corrosion (blank metal)
- Store the machine in dry rooms only

### 8.3. Disposal

All materials used need to be disposed of in a safe and environmentally compatible way. Observe all applicable national regulations! 



... a successful  
connection!

Maschinenfabrik Wagner GmbH & Co. KG  
Birrenbachshöhe · 53804 Much · Germany

**Tel. national:** (02245) 62-0  
**Fax national:** (02245) 62-22  
**Phone international:** +49 (0)2245 62-10  
**Fax international:** +49 (0)2245 62-22

info@plarad.com · www.plarad.com

Reproduction and copying of this volume, in whole or in part,  
is permissible only with express written permission. Subject to  
amendment. We take no responsibility for printing  
errors or inaccurate information.  
Last update: 04/2022

69833

2\_BA\_PSE\_GBR\_1.0\_69833