

**Electric Power Pack**  
**Serie X32**  
IQ-VAX

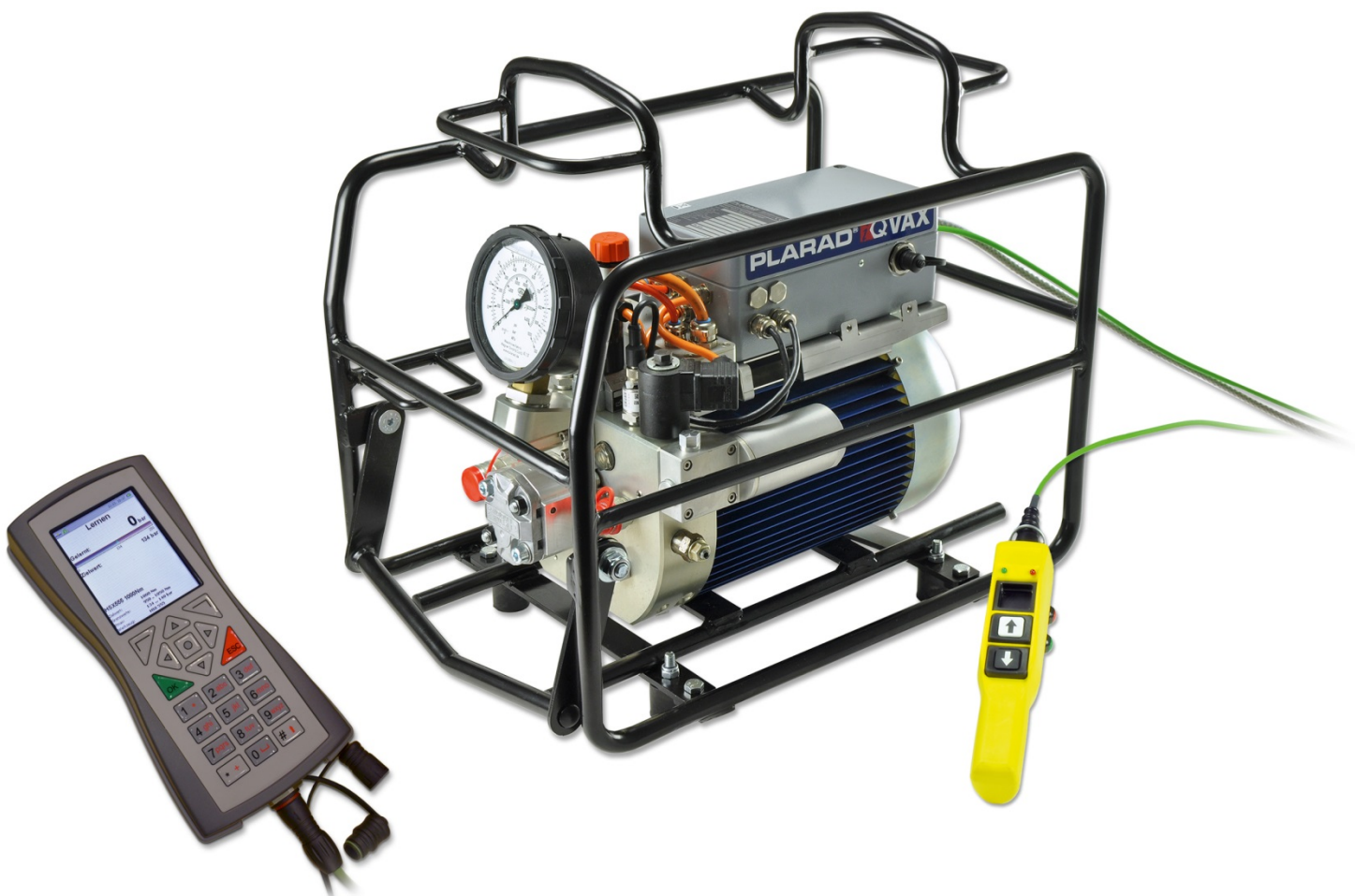

# Operating manual



Store for future reference.



# Contents

<b>Electric Power Pack</b> .....	1
<b>Serie X32</b> .....	1
IQ-VAX.....	1
Operating manual .....	1
<b>1. MANUFACTURER</b> .....	5
<b>2. NOTES</b> .....	5
<b>2.1. CE mark</b> .....	5
<b>2.2. Directives</b> .....	5
<b>2.3. Information about this manual</b> .....	5
<b>2.4. Information about the workplace</b> .....	5
<b>2.5. Fundamental safety instructions on how to use mobile electrical devices</b> .....	5
<b>2.6. Basic safety instructions for use of hydraulic power packs</b> .....	6
<b>2.7. Product identification</b> .....	7
<b>3. PRODUCT INFORMATION</b> .....	8
<b>3.1. Intended use</b> .....	8
<b>3.2. Non-intended or improper use</b> .....	8
<b>3.3. Other applicable operating instructions</b> .....	8
<b>4. SCOPE OF DELIVERY</b> .....	8
<b>5. TECHNICAL DATA</b> .....	9
<b>6. TRANSPORT</b> .....	9
<b>7. PREPARING OPERATION</b> .....	9
<b>7.1. Safety instructions for operation</b> .....	9
<b>7.2. Check the oil level of the power pack and refill oil if necessary; connect the mains voltage</b> .....	10
<b>8.1. Selecting tensioning/loosening mode</b> .....	12
<b>8.2. Additional steps (D1500 dual power packs only)</b> .....	12
<b>8.3. Manual mode (tensioning)</b> .....	13
<b>8.3.1. Setting the desired operating pressure</b> .....	13
<b>8.3.2. Performing the bolting operation</b> .....	14
<b>8.4. Manual mode (loosening)</b> .....	14
<b>8.5. Automatic mode</b> .....	14
<b>8.5.1. Learning</b> .....	14
<b>8.5.2. Tensioning</b> .....	15
<b>8.5.3. Loosening</b> .....	15

<b>9.</b>	<b>TENSIONER OPERATION WITH UP TO 800 BAR</b>	<b>16</b>
<b>10.</b>	<b>TENSIONER OPERATION WITH UP TO 1,500 BAR (D1500 DUAL POWER PACKS ONLY)</b>	<b>16</b>
<b>10.1.</b>	<b>Setting the pressure</b>	<b>16</b>
<b>10.1.1.</b>	<b>Manual pressure setting (recommended: semi-automatic pressure setting, see 0)</b>	<b>17</b>
<b>10.2.</b>	<b>Operation</b>	<b>18</b>
<b>10.2.1.</b>	<b>Operating the tensioner manually (recommended: automatic operation, see 10.2.2.)</b>	<b>18</b>
<b>10.2.2.</b>	<b>Operating the tensioner automatically (recommended)</b>	<b>18</b>
<b>10.2.2.1.</b>	<b>Disabling Automatic Repump Mode (not recommended)</b>	<b>19</b>
<b>10.2.3.</b>	<b>Relieving the tensioner</b>	<b>19</b>
	<b>DOCUMENTED OPERATION (POSSIBLE ONLY IN CONJUNCTION WITH CONTROL UNIT)</b>	<b>20</b>
<b>11.</b>	<b>Connecting the control unit</b>	<b>20</b>
<b>11.2.</b>	<b>Putting the control unit into service</b>	<b>21</b>
<b>11.3.</b>	<b>Using the control unit to control tensioning (D1500 dual power packs only)</b>	<b>21</b>
<b>11.4.</b>	<b>Using the control unit to control the bolting process</b>	<b>24</b>
<b>11.4.1.</b>	<b>Loosening</b>	<b>27</b>
<b>11.5.</b>	<b>Additional features of the control unit</b>	<b>27</b>
<b>11.5.1.</b>	<b>User data input</b>	<b>27</b>
<b>11.5.2.</b>	<b>Viewing documentation and data</b>	<b>28</b>
<b>11.5.3.</b>	<b>Viewing power pack data</b>	<b>28</b>
<b>11.5.4.</b>	<b>Viewing data about the control unit</b>	<b>29</b>
<b>11.5.5.</b>	<b>Modifying settings</b>	<b>29</b>
<b>11.6.</b>	<b>Powering down the control unit</b>	<b>29</b>
<b>11.7.</b>	<b>Data exchange between PC and control unit</b>	<b>30</b>
<b>12.1.</b>	<b>Creating user fields</b>	<b>31</b>
<b>12.2.</b>	<b>Creating/editing bolting applications</b>	<b>32</b>
<b>12.3.</b>	<b>Creating bolting definition lists</b>	<b>33</b>
<b>12.4.</b>	<b>Managing documentation data</b>	<b>33</b>
<b>14.</b>	<b>REMOTE CONTROL DISPLAY</b>	<b>34</b>
<b>15.</b>	<b>LED ON THE REMOTE CONTROL</b>	<b>35</b>
<b>16.</b>	<b>MEMBRANE KEYBOARD OF THE CONTROL UNIT</b>	<b>37</b>
<b>17.</b>	<b>DISPLAY OF THE CONTROL UNIT</b>	<b>38</b>

18.	MAINTENANCE	INSTRUCTIONS .....	38
19.	INSTRUCTIONS ON DISPOSAL .....		39

# 1. MANUFACTURER

Maschinenfabrik Wagner GmbH & Co.KG  
53804 Birrenbachshöhe, Much  
+49 (02245) 62-0

## 2. NOTES

### 2.1. CE mark

The products are labelled with the CE mark. The Declaration of Conformity verifies that the products are in compliance with the safety directives of the European Union.

### 2.2. Directives

The product meets the requirements of the EC Machinery Directive 2006/42/EC.

### 2.3. Information about this manual

This manual contains important instructions on how to operate, set up and connect the power pack. Read these instructions carefully before putting the power pack into operation.

This is for your own protection and will provide you with important information on how to connect and use the power pack in a safe manner.

The operating manual is an integral part of the power pack. Store it close to the power pack where it is available at all times. Observing every detail of the operating manual is a requirement for using the power pack correctly and as intended. For this reason, pass this operating manual on to the next owner when selling the power pack.

Please note that details of the illustrations and technical specifications contained in this operating manual may deviate from the product you purchased.

The information provided in this operating manual is current as of the time it was printed. We reserve the right to make changes without prior notice.

### 2.4. Information about the workplace

We recommend that you use the hydraulic tensioner in one-man operation. The operation of the power pack is restricted to trained and authorised personnel. Conduct a risk assessment before deciding to use the power pack in two-person operation. When using the power pack in two-person operation, ensure that the two users have previously cleared the application, the communication and the coordination of the power pack with one another. The person positioning the tensioner should give the instructions regarding the operation of the power pack even if he is not operating the remote control.

The safety of the operator and the trouble-free operation of the power pack are only guaranteed if you use original PLARAD components. This applies both to power pack components and spare parts.

If different components are used, Maschinenfabrik Wagner cannot guarantee the safe and reliable operation of the power pack.

### 2.5. Fundamental safety instructions on how to use mobile electrical devices

**ATTENTION!** When using electrical devices, you need to observe the following fundamental safety measures to ensure protection against electric shock and the risk of injury and fire hazards.

Read all of these instructions before using this power pack and store the safety instructions in a safe place for future reference.

#### Safe working

1. Keep your work area neat and tidy
  - Disorganisation in the work area may result in accidents.
2. Take environmental influences into consideration
  - Do not expose the power pack to rain. Refrain from using the power pack in a wet or moist environment.
  - Provide for proper lighting in the work area.
  - Do not use the power pack in areas where there is a risk of fire or explosion.
3. Protect yourself against electric shock
  - Avoid bodily contact with grounded components.
4. Keep other persons at a distance
  - Do not allow other people, especially children, to touch the power pack or the cable. Keep them away from the work area.
5. Store unused power packs in a safe location
  - When not in use, the power packs should be stored in a dry, elevated or enclosed location and out of the reach of children.
6. Do not overload your power pack
  - You work better and more safely if staying within the specified range of capacity.
7. Use the correct power pack
  - Do not use low-capacity power packs for heavy-duty work.
  - Do not use the power pack for purposes for which it is not intended.

8. Wear suitable clothing
  - Do not wear loose-fitting clothing or jewellery as these may be caught by moving parts of the power pack.
  - We recommend that anti-slip shoes are worn when working outdoors.
  - Long hair should be protected by a hair net.
9. Use protective equipment
  - Wear safety goggles or approved safety glasses whenever the work may endanger your eyes.
10. Do not use the cable for purposes for which it is not intended.
  - Do not use the cable to pull the plug out of the outlet.
  - Protect the cable against heat, oil and sharp edges.
11. Avoid abnormal body positions
  - When working stand safely and maintain your balance at all times.
12. Service your power packs with care
  - Check regularly the connecting cable of the power pack and have it replaced by an authorised specialist if damage is found.
  - Check regularly extension cables and have them replaced if they are damaged.
  - Keep handles dry, clean and free from oil and grease.
13. Pull the plug out of the power outlet
  - When not using the power pack, before performing maintenance work and when changing tools, disconnect the power pack from the power supply.
14. Use extension cables suitable for outdoor use
  - When working outdoors, use only extension cables that are approved for this type of usage and labelled accordingly.
15. Be alert
  - Pay attention to what you are doing. Work reasonably. Do not use the power pack unless you are fully concentrated.
16. Inspect the power pack for possible damage
  - Before continuing operation, all safety devices or lightly damaged parts must be inspected carefully to verify that they function properly and as intended.
  - Check if the moving parts work properly without sticking or whether parts are

damaged. All parts must be fitted properly and meet all requirements for correct operation of the power pack.

- Unless specified otherwise in the instructions for use, damaged safety devices and parts must be repaired or replaced properly by an authorised specialist workshop.
- Damaged switches must be replaced by a customer service workshop.
- Do not use any power packs on which switches cannot be turned on and off.

**Maintenance, servicing, and repairs**

Pull the power plug before adjusting any settings and prior to servicing or repairs.

Allow only an electrically skilled person to repair your power pack.

This electrical power pack conforms to all applicable safety regulations. Repairs may only be performed by an electrically skilled person using original spare parts; otherwise the user may experience accidents.

**2.6. Basic safety instructions for use of hydraulic power packs**

When operating the power pack, be sure to observe locally applicable laws and regulations.

Verify every time before using the power pack that the power pack operates in a reliable manner and is in proper condition.

The user must be familiar with the operation of the power pack. Before putting the power pack into operation, check the hose line(s) for damage. Replace any damaged hose lines, couplings and nipples without delay.

Do not couple/uncouple connected devices unless the power pack is switched off. Otherwise, the power pack may be damaged and hydraulic fluid may escape. This may result in eye injuries and burns. In case of contact with operating materials or consumables, follow the material safety data sheets and the product information relating to the operating materials.

When using an extension cord with a small cross-section and a great length, a voltage drop may occur. This will affect the start-up performance of the motor. Use only extension cables that meet the following requirements:

Mains voltage	Minimum cross-section
230/400 V	1.5 mm <sup>2</sup>
100/110 V	2.5 mm <sup>2</sup>

When working outdoors, use only extension cables that are approved for this purpose and labelled accordingly.

### 2.7. Product identification

The power pack is identified by the nameplate that is found on the cover of the control housing.

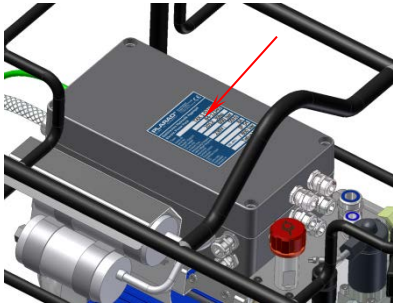

10	1	2	3	4	5
11	next maintenance				6
12	nächste Überprüfung				7
13	12	11	10	9	8

Service seal specifying the date of the next inspection



WEEE recycling/disposal instructions. This product must not be disposed of with regular household waste.

### 2.8. Symbols and Warnings



CE mark



Follow the instructions for installation and use



Wear hearing protection



Wear eye protection



Hazard warning. The hazard category is specified in the text found next to the respective warning



Warning of dangerous electrical voltage



Warning of hot surface

## 3. PRODUCT INFORMATION

### 3.1. Intended use

The PLARAD power pack is a mobile hydraulic power generator that is used to power PLARAD hydraulic torque wrenches or PLARAD tensioners for the purpose of creating bolted connections. The power pack may only be used for commercial purposes and only in connection with PLARAD tensioners.

The power pack is designed for indoor and outdoor operation at ambient temperatures of -10°C to +50°C. If intending to deviate from these conditions, consult the manufacturer first.

The power pack can be connected to a stationary factory mains network or a mobile power generator provided the power requirements specified under "Technical specifications" are observed.

Allow only Maschinenfabrik Wagner or bodies authorised by Maschinenfabrik Wagner to install, readjust, modify, upgrade and repair the power pack. Use the power pack only as described in the operating manual. Operating the power pack in a safe and reliable manner will otherwise not be possible. Unauthorised modifications may lead to unexpected hazards.

The safety of the operator and the trouble-free operation of the power pack are only guaranteed if you use original PLARAD components. This applies both to parts of the power pack and spare parts.

If different components are used, Maschinenfabrik Wagner cannot guarantee the safe and reliable operation of the power pack.

### 3.2. Non-intended or improper use

Any use deviating from or exceeding the scope of intended use is considered to be improper. The risk lies solely with the owner / user.

### 3.3. Other applicable operating instructions

BGR/GUV-R 194 Use of hearing protection  
BGR 237, Rules for safe use of hydraulic hose lines  
Shell Tellus S2 V 15, PD / MSDS

## 4. SCOPE OF DELIVERY

Power pack, filled with oil and ready for use

### Consumables (order more if necessary)

Filter cartridge 10µm	K20-058-4-27901
Hydraulic oil 1 l Shell Tellus S2 V 15	K20-001-4-16402
Hydraulic oil 5 l Shell Tellus S2 V 15	K20-001-4-16404

### Control unit (optional accessory)

The following parts belong to the optional scope of delivery "Documentation":

- Control unit
- Docking station for control unit
- Power supply unit
- Adapter cable - power pack
- Network adapter
- Network cable
- PC software application X32
- Software - network adapter



## 5. TECHNICAL DATA

Maximum operating pressure	800 bar (1,500 bar in pressure booster mode in "D1500" dual power packs)
Minimum power input for mobile power generators	4 kVA
L x W x H*	approx. 500 x 350 x 430 mm
Volume flow - dual stage power packs*:	
10 to 70 bar	6.0 to 10.0 l/min
70 to 800 bar	1.2 to 3.0 l/min
Volume flow - single stage power packs*	0.8 to 3.0 l/min
Weight*	22 to 40 kg
Mains connection	See type plate
Sound pressure level (80083.7 to 89.2 dB(A) 1m bar)*	**

## 6. TRANSPORT

When using a crane or similar lifting gear for transport, attach the power pack at the attachment points identified below.

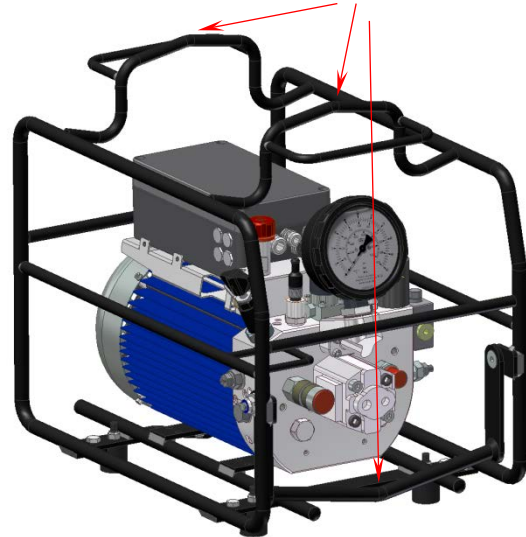

## 7. PREPARING OPERATION



\* actual performance characteristics and dimensions/weights vary with type and model  
 \*\*when the power pack is in operation, the sound pressure level drops by 6 dB(A) with every meter of distance.

This section contains a brief description of all controls and connections. The operating steps explained here are necessary for the safe use of the power pack.

### 7.1. Safety instructions for operation

#### Information about operating temperatures

When operating in temperatures of -5 °C or less, keep starting the power pack until the motor starts running (several times if necessary). Set the pressure relief valve to 400 bar. Do not connect a hose or tensioner and let the power pack run for 5 minutes while holding down the button "manual." By doing so, you are allowing the hydraulic oil to reach its necessary operating temperature before work begins.

	<p><b>Caution</b></p> <p>Noise emission of approx. 85 dB(A).  <b>Wear hearing protection in accordance with EN 458 if the distance between operator and power pack is less than 2 m during operation (BGR/GUV – R 194)</b></p>
	<p><b>Warning!</b></p> <p>The power pack can reach surface temperatures of up to 80°C during extended operation and in high ambient temperatures.  <b>Wear heat-resistant safety gloves! Allow the power pack to cool off before moving it.</b></p>
	<p><b>Warning!</b></p> <p>Unless set up securely, the power pack may tip over or fall down.  <b>Make sure the power pack always stands firmly on a level surface with all four feet!</b></p>



**Warning!**

Hot hydraulic fluid may escape under great pressure and cause severe burns and cutting injuries.

**Verify that the power pack is tight before putting it into service and while operation is in progress. If detecting any leaks, shut down the power pack and repair it before putting back into operation.**

**7.2. Check the oil level of the power pack and refill oil if necessary; connect the mains voltage**

1. Check the oil level. While doing so, make sure the power pack is standing horizontally to ensure a proper reading of the oil level.

The oil level is OK if the oil level sight glass is half-filled.

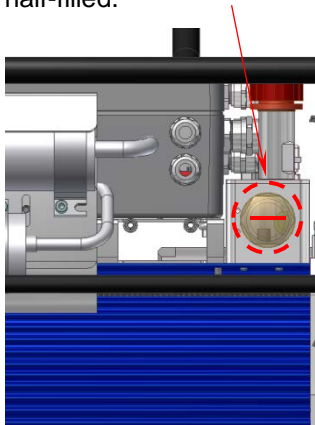

2. If the oil level is not OK, fill in hydraulic oil using the oil filler neck until the oil level sight glass is half-filled.
3. Check the mains connection lead for damage and do not connect it unless you find no damage.
4. Compare the power supply specified on the type plate with the available mains supply or the specifications of the mobile power generator. Do not connect the power plug to the power supply unless the specifications match.

The power pack starts up performing a self-test. During this test, the indicator lights on the power pack and the remote control light up for approx. 5 seconds.

While the self-test is in progress, the remote control may show error messages for a brief period of time. If these error messages are still indicated when the self-test is complete, the power pack needs to be turned in for service.

**7.3. Select special functions with the remote control**

The selection of Special Functions is by pressing and holding the red button.

The unit switches it off if necessary.

You will see a context-sensitive help screen.

This describes the function, which is triggered when (during the red button still held) is another key is pressed.

The following figure shows such a help screen examples:



Depending on the condition of the unit and the available options individual lines (functions) can be omitted in this particular case or replaced by others.

The aggregate has recognized the (further) keystroke, you can tell that the setting is highlighted in green.

example:

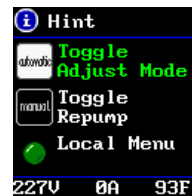

**7.4. Carry out the basic settings of the power pack**

Before you start operation, you can use the menu "Settings" on the remote control to carry out the basic settings for your power pack.

1. To access this menu, press and hold the red button (for at least 2 seconds) while pressing the green button at the same time.



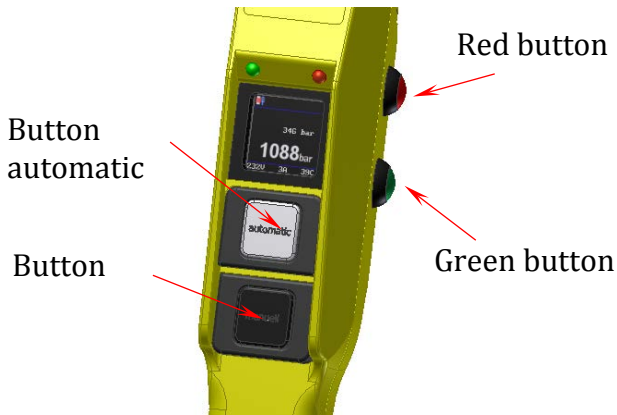

2. Use the buttons "automatic" and "manual" to navigate through the menu.

Use the green button to select a child menu.  
Use the red button to return to the previous menu level.

3. Select the desired language for the remote control in the child menu "Language."



4. Press the green button to store the language setting.

5. Press the red button to exit the menu.

6. Adjust the display contrast in the child menu "Contrast." To do so, select the menu item "Contrast" using the green button.



7. Adjust the contrast using the buttons "automatic" and "manual."

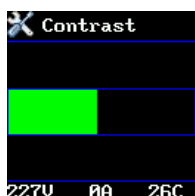

8. You can use the child menu "Information" to bring up various information about the power pack such as the serial number and the operating hours.

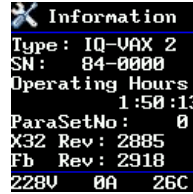

9. You can select the units in which you wish to display these values in the child menu "Temp." and "Pres." Temperature and pressure can be indicated in degrees Centigrade or degree Fahrenheit and bar or psi, respectively. Press the green button in each case to toggle the units.



### 7.5. Preparing the power pack

1. Connect the hydraulic hoses to the hydraulic power pack.

The pressure port on the hydraulic power pack is fitted with a coupling. (This applies when the CEJN series 115 is used, individual power packs may be furnished differently.)

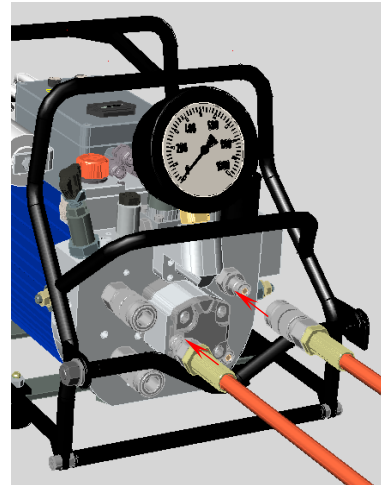

2. Do *not yet* connect the hydraulic nutsetter.
3. Connect the hydraulic hoses to one another at the other end. If you are operating the unit in twin-mode, connect both hose pairs to one another.

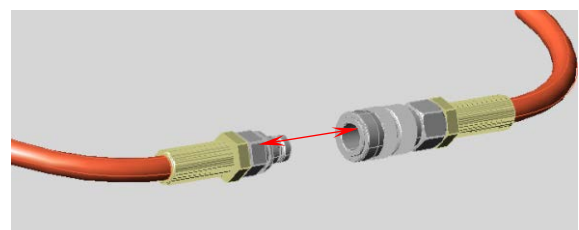

Depending on which mode is selected, flashes "busy power pack" to indicate, either the red or the green LED rapidly. Since the aggregate executes a return stroke after each start and notably because of the hydraulic hoses but cannot build up pressure, the return stroke is never finished. Thus, the LED flashes as long as required to by pressing on the red button, the engine is turned off. The current return stroke ensures a flushing of the hydraulic hoses. This entrapped air is removed from the hoses if necessary present.

## 8. WORKING WITH HYDRAULIC TOOLS



**Attention!** When setting the hydraulic pressure, you must never exceed the maximum permissible operating pressure of the tool you are using (see torque table).

### 8.1. Selecting tensioning/loosening mode

With the red button depressed, you can use the button "manual" on the remote control to toggle between tensioning mode and loosening mode.



- The set mode is indicated by the indicator lights on the remote control:
 

<b>green</b>	Indicator light	<b>Tensioning mode</b>
<b>red</b>	Indicator light	<b>Loosening mode</b>

The procedure used to select tensioning/loosening mode is the same for all modes of operation.

### 8.2. Additional steps (D1500 dual power packs only)

"Dual power packs" are fitted with a pressure booster on their front end, which allows you to operate tensioners with a maximum pressure of up to 1,500 bar.



Set the changeover valve - pressure booster to bolting mode. When the valve is in the 12 o'clock position, the power pack is set to 1,500 bar (pressure is supplied to the tensioner pressure port on the side), while the 6 o'clock position supplies 800 bar (pressure is supplied to the hydraulic tool pressure ports at the front).

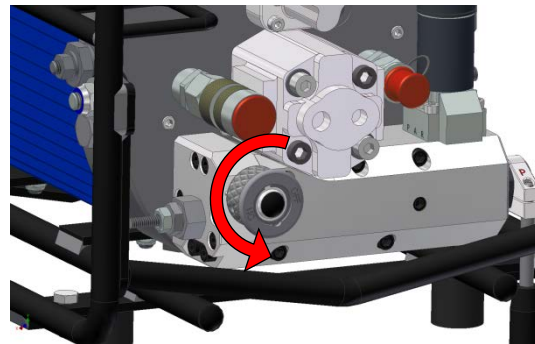

Setting the changeover valve - pressure booster to tensioner mode

The manual pressure relief valve must be open.

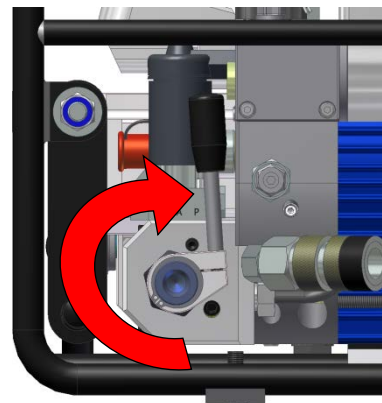

Opening the pressure relief valve

If the red indicator light on the control enclosure is on, press the yellow button to switch the indicator light off: The power pack is now set to bolting mode.

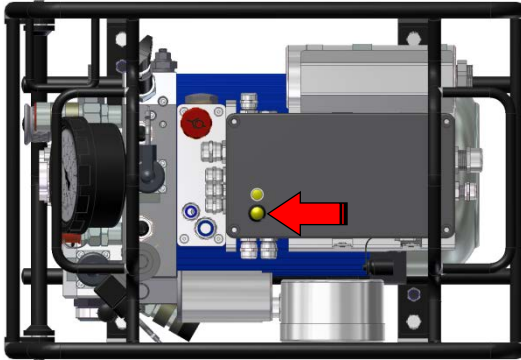

Toggle button - tensioner mode

8.3. Manual mode (tensioning)

8.3.1. Setting the desired operating pressure

- Manual operation does not require a learning mode.
- Press and hold the button "manual" on the remote control and set the required hydraulic pressure at the pressure adjusting valve.

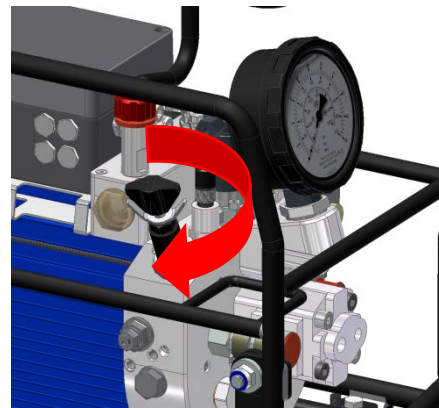

Pressure adjusting valve

- For the pressure that needs to be set, refer to the torque table of the hydraulic tool.
- The pressure is indicated at the pressure gauge of the power pack and on the display of the remote control.



The remote control will indicate the following status:



Learning

Before you can perform bolting operations in automatic mode, you must first run the power pack in learning mode (see chapter 0). **Manual bolting, on the other hand, merely requires that you set the necessary pressure!**

### 8.3.2. Performing the bolting operation

Connect the hydraulic torque wrench with the hydraulic lines and place it onto the bolting.

Press the button "manual" = hydraulic tool moves forward and turns the fastener.

Release the "manual" button = hydraulic tool moves back.

- This process is repeated until the rotation of the bolting tool is no longer visually detectable. When bolting is complete, switch off the power pack using the red button on the remote control.

### 8.4. Manual mode (loosening)

- When setting the hydraulic pressure, you must never exceed the maximum permissible operating pressure of the tool you are using (see torque table).
- Place the hydraulic torque wrench onto the bolt.

Press the "manual" button = hydraulic torque wrench moves forward.

Release the "manual" button = hydraulic torque wrench moves back.

- Repeat this process until the bolting has been loosened. When bolting is complete, switch off the power pack using the red button on the remote control.

### 8.5. Automatic mode

#### 8.5.1. Learning

- Connect the hydraulic hoses with the hydraulic torque wrench after bleeding them.

Do not yet place the hydraulic torque wrench onto the bolt.

- Switch on the power pack by pressing the button "manual."
- Set the pressure as specified in chapter 0.

Learning operations can be performed both in loosening and tensioning mode.

If the indicator lights blink slowly, learning has not been completed yet. The display shows the learning icon in the header.



- Press and hold the "automatic" button during learning. Learning mode will be completed automatically while you are holding this button down. The hydraulic tool will complete several work cycles while the measurement is being taken.
- The process involves the measurement of several values which are necessary to control the hydraulic tool automatically. The values are never measured for components other than the ones connected to the power pack.
- When the learning process/calibration has been completed successfully, the green indicator light (or red indicator light if the calibration was performed in loosening mode) on the remote control will stop blinking and light up permanently, and the icon indicating bolting mode on the remote control display will switch from learning to tensioning (or to loosening if the calibration took place in loosening mode).

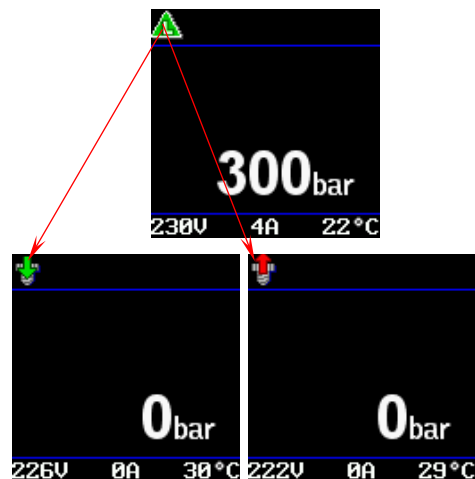

- If both indicators blink alternately when learning is complete, an error has occurred, requiring you to repeat the process; (see list of remote control error messages).

The bolting system is now prepared for automatic operation.

- You can delete the measured values programmed into the memory of the power pack control. To do so, press the red button and the "automatic" button on the remote control at the same time. When erasing is complete, the corresponding indicator light will switch from permanent light to blinking slowly.
- The measured values stored in the memory will also be deleted by disconnecting the power pack from the mains voltage.

### 8.5.2. Tensioning

Unless you are using the control unit (optional accessory), you will only be able to torque bolted connections.

- Start the power pack by pressing the "manual" button. Wait until the green LED stops blinking and lights up permanently.
- Place the hydraulic torque wrench onto the bolt.
- Start the bolting process by pressing and holding the "automatic" button. The green indicator light starts blinking rapidly.
- The bolting process is performed automatically.
- Once the bolting process is complete, the green indicator light switches from blinking to permanent light. The bolting process has been completed properly. The remote control displays the following message:

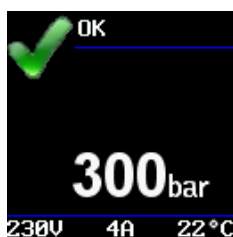

- If the indicator lights blink upon the completion of the process, an error has occurred, for instance by setting the pressure at the power pack too high. An error message like this will prevent you from further controlling the power pack. The remote control displays the following message:



- If the bolting process is cancelled by the user, the following message will appear:



- Pressing the "automatic" button will reset the error message/abort message, allowing you to reassume control of the power pack.

### 8.5.3. Loosening

- Place the hydraulic torque tool onto the bolt.
- Start the power pack by pressing the "manual" button. Wait until the red LED stops blinking and lights up permanently.
- Start the loosening process by pressing and holding the "automatic" button. The red indicator light starts blinking rapidly. The remote control displays the following screen:



- The loosening process will not be terminated automatically, but requires the user to end it by releasing the "automatic" button

## 9. TENSIONER OPERATION WITH UP TO 800 BAR

Before starting the actual bolting process, read the pressure necessary to generate the required tension in the tensioning force table of the tensioner and set this pressure at the pressure relief valve of the power pack with the hydraulic hose connected, but **without previously connecting the tensioner**.

1. For this purpose, press and hold the "manual" button while turning the pressure relief valve at the same time in order to set the necessary pressure.

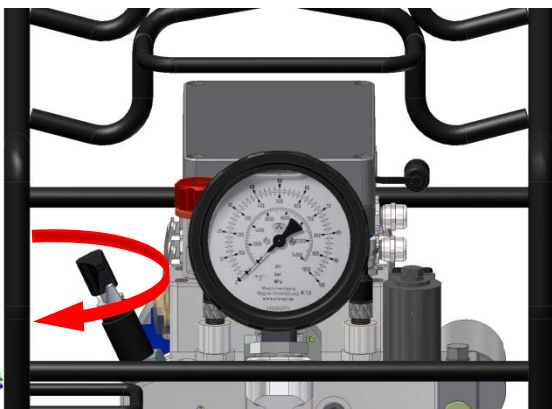

Pressure adjusting valve



**Attention!** While adjusting the pressure, you must make sure that the tensioner is not connected to the power pack!

2. Now connect the tensioner to the hydraulic hose. Before doing so, make sure the power pack is switched off.
3. The power pack is now ready to power the tensioner.
4. You can now place the tensioner onto the bolting.
5. Press the "manual" button to allow the tensioner to generate the necessary tensioning force until the system has reached the pressure previously set at the pressure relief valve and keep the button depressed as the tensioner will otherwise be relieved again.
6. Releasing the "manual" button will relieve the system again, allowing you to remove the tensioner from the bolting again.

## 10. TENSIONER OPERATION WITH UP TO 1,500 BAR (D1500 DUAL POWER PACKS ONLY)

### 10.1. Setting the pressure

A pressure booster is mounted on the front end of the power pack, which allows you to operate tensioners with a maximum pressure of up to 1,500 bar.

1. To build up pressure, close the manual pressure relief valve.

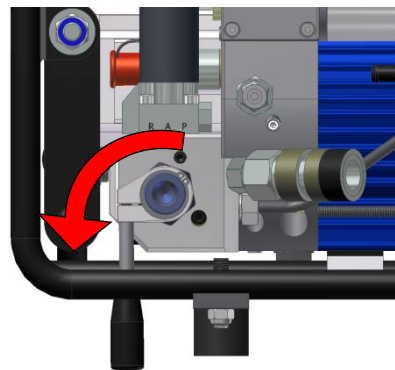

2. Set the changeover valve - pressure booster to tensioner mode. When the valve is in the 12 o'clock position, the power pack is set to 1,500 bar (pressure is supplied to the tensioner pressure port on the side), while the 6 o'clock position supplies 800 bar (pressure is supplied to the hydraulic torque wrench pressure ports at the front).

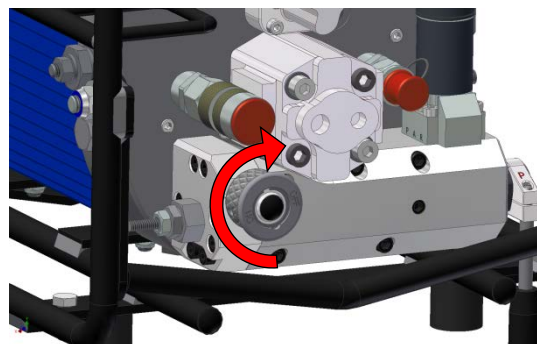

3. If the red indicator light on the control enclosure is off, press the yellow button to switch the indicator light on: The power pack is now set to tensioner mode.



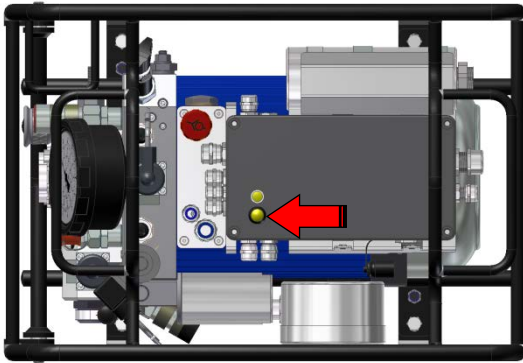

The bottom line of the remote control display indicates the pressure in the high pressure section of the power pack (the operating pressure that is supplied to the coupling of the power pack). The upper (short) line shows the inlet pressure of the pressure booster:

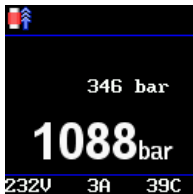

4. Connect the hydraulic hose to operate the tensioner with the hydraulic coupling attached on the side.



**Warning!**

Hot hydraulic fluid may escape under great pressure and cause severe burns and cutting injuries.

**Use only hydraulic hoses that are approved for this pressure range (1,500 bar)!**

**10.1.1. Manual pressure setting (recommended: semi-automatic pressure setting, see 0)**

1. Press the button "manual" to start the power pack.
2. Read the required tension in the tensioning force table of the tensioner.
3. Fully open the pressure relief valve.
4. Set the pressure you read at the pressure relief valve of the power pack as described in the next step.

**The hydraulic hose must be connected for this purpose. However, the tensioner must *not* be connected.**

5. Press the "manual" button repeatedly while turning the pressure relief valve clockwise

until the remote control indicates the desired pressure (lower indicator of the two pressure indicators).

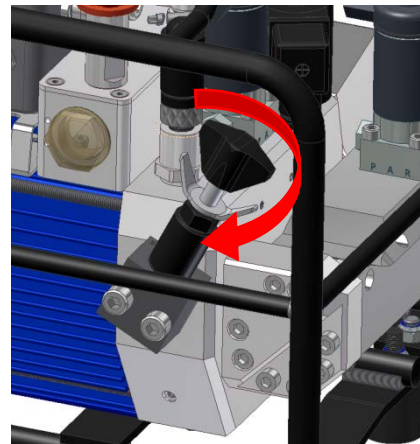

6. Relieve the power pack if you accidentally set the operating pressure too high. Do not set the pressure again until you have done so (the system will otherwise retain the incorrect pressure setting).

To relieve the pressure:

- Press the green button on the remote control.
7. Repeat the pressure setting procedure.
  8. Relieve the pressure from the power pack when the pressure has been set correctly:
    - Press the green button on the remote control.
  9. Switch off the power pack.
  10. Connect the tensioner to the hydraulic hose.

The power pack is now prepared for operation with the tensioner. You can place the tensioner onto the bolting.

**10.1.2. Semi-automatic pressure setting (recommended)**

1. Another option is to set the pressure in the so-called pressure adjustment mode. To switch to pressure adjustment mode, press the "automatic" button while holding down the red button. The following screen will pop up:



When the switch was made successfully, "Toggle Adjust Mode" will be marked green:

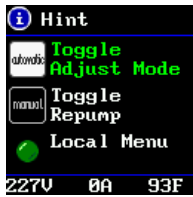

- The following icon will be shown on the display after you selected pressure adjustment mode:



- Press the button "manual" to start the power pack.
- Read the required tension in the tensioning force table of the tensioner.
- Open the pressure relief valve all the way.
- Set the pressure you read at the pressure relief valve of the power pack as described in the next step.

**The hydraulic hose must be connected for this purpose. However, the tensioner must *not* be connected.**

Press and hold the "automatic" button while turning the pressure relief valve clockwise until the remote control indicates the desired pressure (lower indicator of the two pressure indicators).

- If you accidentally set a pressure that is too high, release the "automatic" button; the power pack will release pressure automatically, allowing you to repeat the process that is described under step 6.
- When the pressure has been set correctly, press the "automatic" button while keeping the red button depressed at the same time in order to exit automatic pressure adjustment mode. The icon indicating that you are in pressure adjustment mode will disappear again:

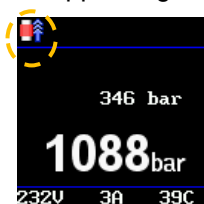

- Switch off the power pack.

- Connect the tensioner to the hydraulic hose.

The power pack is now prepared for operation with the tensioner. You can place the tensioner onto the bolting.

## 10.2. Operation

### 10.2.1. Operating the tensioner manually (recommended: automatic operation, see 10.2.2.)

- Press the button "manual" repeatedly to allow the tensioner to generate the required tensioning force until the previously set pressure has been reached.
- The remote control indicates the pressure in front of the pressure booster (upper line) and the high pressure present upstream of the pressure booster (lower line = operating pressure of the tensioner).



When in this mode, you need to watch the pressure indicator while adding the fastener and increase the pressure again by pressing the "manual" button repeatedly if it has dropped below the required minimum level.

- Tighten the fastener.
- Relieve pressure from the tensioner after tightening the fastener:

Press the green button on the remote control.

### 10.2.2. Operating the tensioner automatically (recommended)

- Press and hold the "automatic" button to perform the tensioning process.
- You can follow the pressure build-up on the remote control display.
- The power pack will automatically stop generating any more pressure once the preset pressure has been reached.
- Influences such as settling losses may cause the original hydraulic pressure that was reached inside the system to drop again. To set off such pressure losses automatically, a so-called Automatic Repump Mode is enabled when the

power pack operates in automatic tensioning mode.

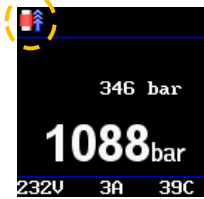

This is indicated by the icon marked in the illustration above (triple arrow).

5. Automatic repumping is activated automatically by the power pack if the pressure drops by 10 bar.
6. If the set pressure has been reached with Automatic Repump Mode enabled, the remote control will show the following screen as confirmation:



7. Tighten the fastener.
8. Relieve pressure from the tensioner after tightening the fastener:  
Press the green button on the remote control.
9. While Automatic Repump Mode is enabled, you can still initiate a pressure build-up again by pressing the buttons "automatic" or "manual."

### 10.2.2.1. Disabling Automatic Repump Mode (not recommended)

To disable automatic repumping, press the button "manual" while keeping the red button depressed at the same time. The following screen will pop up:



When the switch was made successfully, "Toggle Repump" will be marked green:

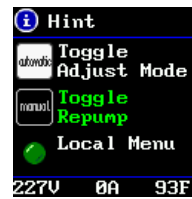

Use the same button combination to switch automatic repumping back on. When Automatic Repump Mode is disabled, the display will show the following icon in the top left corner (single arrow):



The power pack will now no longer repump automatically should the tensioning force drop as a result of, for instance, setting losses. When Automatic Repump Mode is disabled, the remote control will indicate that the set pressure has been reached by showing the following screen:

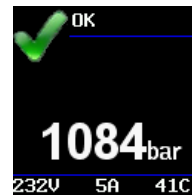

When in this mode, you need to watch the pressure indicator while adding the fastener and re-increase the pressure by pressing the "automatic" button again if it has dropped below the required minimum level. **We, therefore, recommend that you do not disable Automatic Repump Mode.**

### 10.2.3. Relieving the tensioner

The system maintains the pressure generated by the powerpack (with the exception of any pressure losses that may occur due to settling processes, etc.). Before you can remove the tensioner, you must relieve the pressure from the system:

1. Press the green button on the remote control.

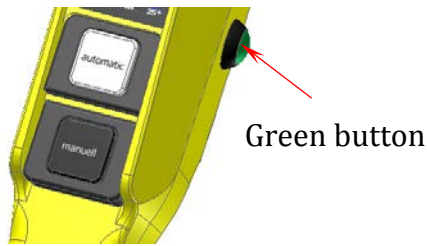

2. The power pack will now be relieved until the motor cuts off or you initiate another pressure build-up by pressing the "manual" or the "automatic" button.
3. Remove the tensioner from the bolting.
4. In the event of a fault (e.g. a power outage), you can also relieve the tensioner manually. Open the pressure relief valve of the pressure booster for this purpose.

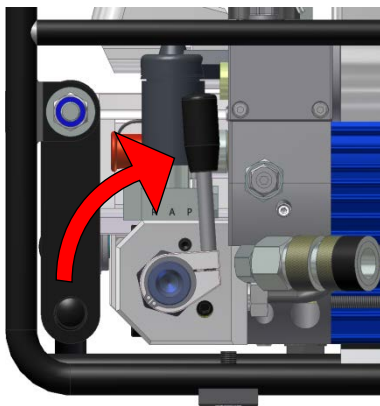

**DOCUMENTED OPERATION (POSSIBLE ONLY IN CONJUNCTION WITH CONTROL UNIT)**

Documented hydraulic torque wrench/tensioner operation requires the use of a control unit (optional accessory). When creating your bolting applications using the PC software application "BE32.exe", make sure to create these bolting applications in the desired mode (torque, torque-angle, bolting or tensioner mode). You may not be able to use your power pack in all modes depending on the power pack you purchased!

## 11. Connecting the control unit



1. Connect the control unit to the power pack using the "Adapter cable - power pack."



2. Connect the red port with the control unit.
3. Plug the blue connector into the corresponding port on the control enclosure of the power pack.
4. Connect the power pack to the mains supply.

The control unit will be supplied with power for as long as it remains connected to the power pack. Its battery, however, will not be charged. Use the included docking station to recharge the battery pack. The docking station must be connected to the power supply unit for this purpose.



On a fully charged battery, the control unit can run for approx. 2 hours without a connection to an external power supply.

### 11.2. Putting the control unit into service

1. Press the  button to turn the unit on:



The control unit initialises. The following screen will appear after a few seconds:

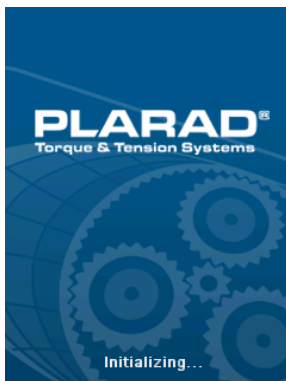

If the control unit has never been synchronised with a PC, the following message will be displayed:

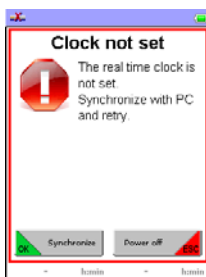

2. In this case, you will have to synchronise the control unit with a PC first to set its clock (see chapter 0). Repeat the start-up process afterwards.
3. If this message pops up for a control unit that has already been synchronised, the battery of the internal clock is defective and should be replaced by Maschinenfabrik Wagner or one of its authorised service partners.
4. Once the data link between control unit and power pack has been established, the "Power pack" menu will appear, showing such information as the type

and the serial number of the power pack that is connected to the control unit.

A proper connection between power pack and control unit is indicated by the following icon:

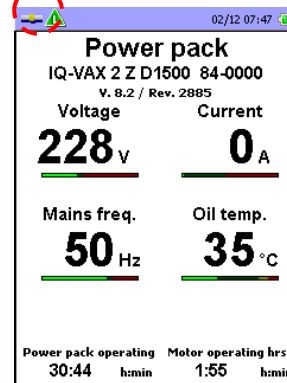

The top right corner of the header holds the charging status of the control unit battery. When the control unit is connected to the docking station or the power pack, an additional connector icon will indicate this connection (supply by an external power supply).

A faulty connection between power pack and control is indicated as follows:

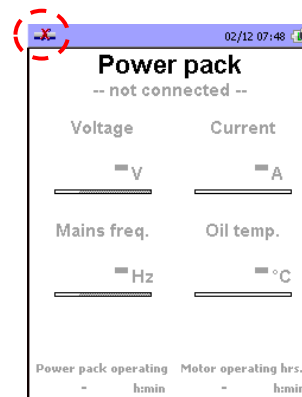

5. Check the connection between power pack and control unit and correct it if necessary.



### 11.3. Using the control unit to control tensioning (D1500 dual power packs only)

#### Preparation

For information on how to create and transfer bolting applications to the control unit, refer to chapter 0. The control unit will not be ready for tensioning unless the bolting applications have been previously transferred from the PC.



1. Press the button  on the control unit to call up the main menu of the control unit.

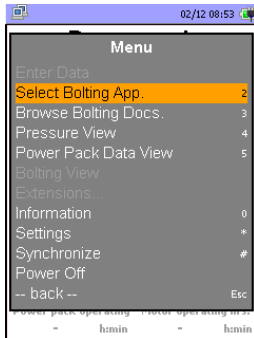

2. Use the buttons  /  to select the child menu "Bolting Application Definitions" and confirm your selection by pressing .



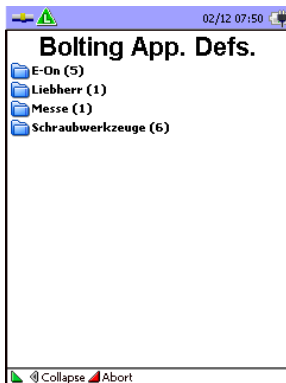

An overview with lists of available bolting applications appears.

3. Use the buttons  /  to select the desired list and press  to confirm your selection.



The list you selected appears.



4. Use the buttons  /  to select the desired bolting application and press  to confirm your selection.

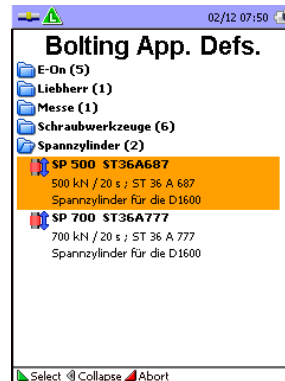

5. You can only select bolting applications which have previously been transferred from the PC to the control unit and stored in the lists of bolting applications. Make sure to select a bolting application on the control unit that has been created in tensioner mode. Corresponding bolting applications are marked with the following icon:



Once the bolting application has been selected, the associated parameters will be transmitted to the power pack.

6. Use the pressure relief valve to adjust the pressure in order to set the value for the pretensioning force in kN that is displayed on the control unit (see chapt. 0). **You will not be able to adjust the pressure using the control unit unless you enabled pressure adjustment mode by pressing the button "automatic" and the red button at the same time. When finished adjusting the pressure, press this button combination again to exit pressure adjustment mode and**

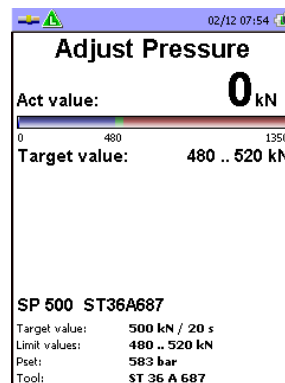

send a message to the control unit that the required pressure has been set.

The control unit displays the data input window:

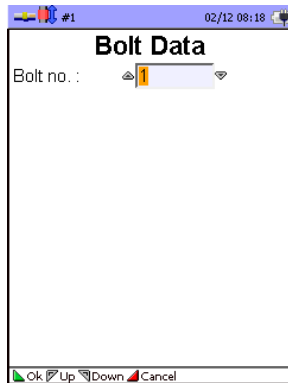

You can use the child menu "Bolt Data" to enter data about the bolting in six free text fields (e. g. operator's name, operator's ID, workpiece designation, etc.).

You can use the button  to toggle between lower and upper case letters resp. numbers.

The illustration below shows that the user created only one field named "Bolt no."

Use the included PC software application to define the number and designation of the fields. The control unit does not allow you to make any changes. All you can do is enter data in the fields provided you selected a bolting application beforehand.

Press the button  to confirm your entries and have the control unit display the selected bolting application. You will find the number of the next bolting (see mark) at the top of the display:

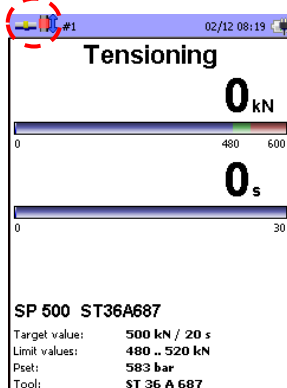

When the tensioner has been connected to the hydraulic hose, the system is ready for the documented operation of the tensioner.

### Tensioning process

1. Press and hold the "automatic" button on the remote control to start the documented tensioning process. The

pressure build-up is displayed on the control unit:

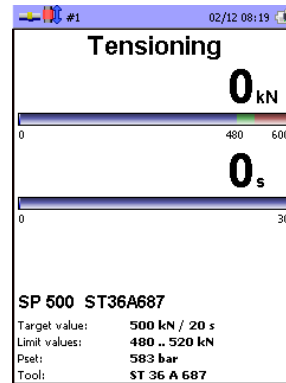

Keep the button depressed until the green and the red indicator light on the remote control light up permanently at the same time. The generated tensioning force is within the tolerance limit, which is indicated by the control unit as follows:

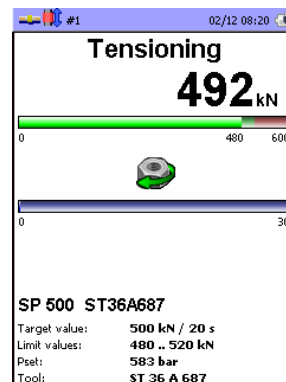

The remote control display will show the following screen:



2. Tighten the fastener.
3. If you use the control unit, the power pack will also repump in each case if the generated pressure drops again as a result of, for instance, setting losses.
4. Relieve pressure from the tensioner after tightening the fastener:

Press the green button on the remote control.

### Documentation of the tensioning process

The control documents the pressure measured immediately prior to the depressurisation as a result of the bolting process.

If the tensioning process was completed successfully, the control unit will display the following message:



You will not have to press the  button to acknowledge the completion message if the tensioning process was completed successfully. You can proceed immediately with the next tensioning process. The number of the bolting is counted up automatically.

**Faulty tensioning process**

If you cancel the bolting process by pressing the red button on the remote control, the control unit will display the following message:

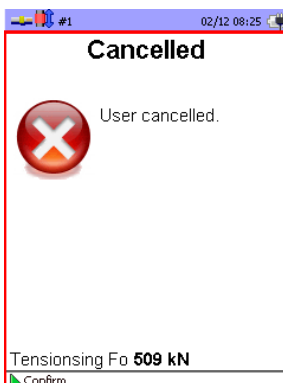

Other error messages, which will be displayed if, for instance, the maximum permissible tensioning force was exceeded by an inadvertent adjustment of the pressure adjusting valve, will also be shown as clear text messages:

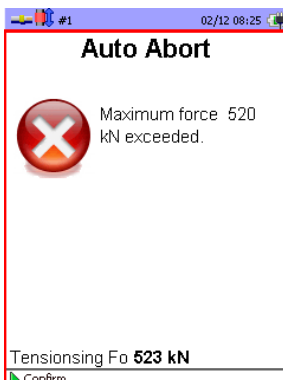



If an error message has occurred, the number of the bolting will not be counted up automatically.

**11.4. Using the control unit to control the bolting process**



This type of use requires that you select a bolting application in the menu "Bolting Application Definitions" that has been created in torque mode or torque-angle bolting mode. Please note that torque-angle bolting applications cannot be completed unless you are using a power pack that is suitable for this purpose! The control unit will detect whether the connected power pack is capable of performing torque-angle bolting applications. If the power pack is not designed for such applications, any torque-angle bolting applications stored on the control unit may be greyed out.

1. Press the button  on the control unit to call up the main menu of the control unit.

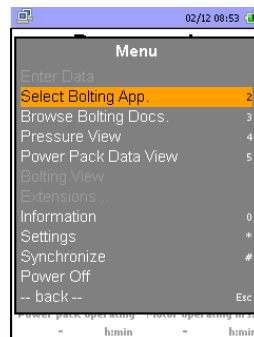

2. Use the buttons  /  to select the child menu "Bolting Application Definitions" and confirm your selection by pressing .



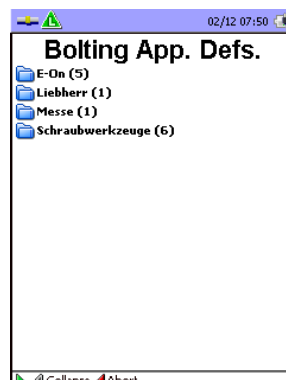

3. An overview with lists of available bolting applications appears.
4. Use the buttons  /  to select the desired list and press  to confirm your selection.





5. The list you selected appears.



6. Use the buttons  /  to select the desired bolting application and press  to confirm your selection.

You can only select bolting applications which have previously been transferred from the PC to the control unit and stored in the lists of bolting applications.

Once the bolting application has been selected, the associated parameters will be transmitted to the power pack.

7. When you have selected a bolting application, the screen "Calibration Stroke" will appear.

If the calibration pressure matches a bolting pressure that may have been calibrated previously and you are using the same hydraulic tool, the screen "Calibration Stroke" will not be displayed as no calibration is necessary, and you will be able to start bolting right away. If the power pack needs calibrating, the marked icon in the status bar will indicate that calibration is required.

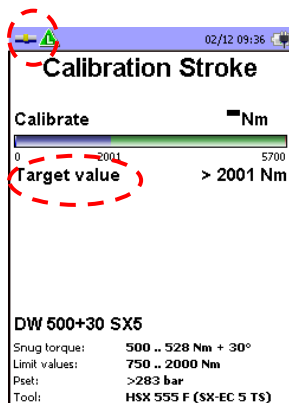

8. Use the hydraulic hose to connect the hydraulic torque wrench to the power pack.

Proceed by adjusting the pressure: **When performing torque bolting applications, you must use the pressure relief valve on the power pack to set precisely the same pressure ("target value") that corresponds to the torque displayed.** If torque/angle bolting applications have been selected, the torque displayed by the control unit is a minimum value. You need to set the power pack to a pressure of your choice provided it corresponds to a torque that exceeds the minimum value.

9. While adjusting the pressure, watch the increase of the resulting torque on the control unit:



Example Torque-Angle Bolting Application – Value of the set pressure corresponds to a torque of 2,144 Nm, thereby exceeding the target value of 2,001 Nm => result is OK.

**If the necessary pressure has been set properly, the bar display indicating the torque is green.**

 **Attention!** Never set the power pack to a pressure that exceeds the maximum permissible operating pressure of the connected hydraulic torque wrench!

10. Proceed by completing the calibration process as described in chapter 0.

11. Any error occurring during calibration will be indicated by an alternating blinking of the indicator lights on the remote control as well as a clear text message on the control unit (see chapter 13. Error **MESSAGES**) .

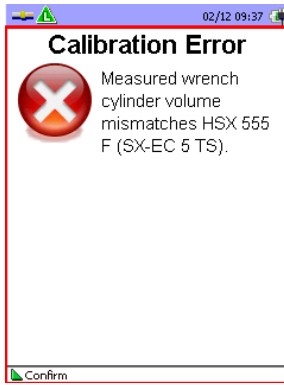

12. Calibration must be repeated once the cause of the error has been eliminated. A properly progressing calibration process is indicated by the switching of the green indicator light on the remote control from blinking to permanent light.
13. After successfully undergoing calibration, the power pack is prepared for automatic bolting processes and their documentation on the control unit. Also, following successful calibration, the control unit will display the corresponding bolting screen which indicates the bolting process associated with the bolting application (torque or torque-angle bolting):

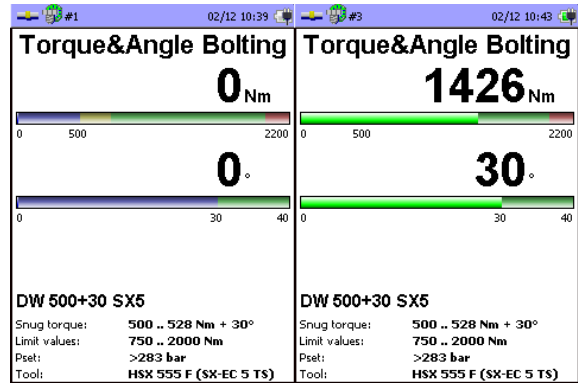

Example Torque-Angle Bolting Process (left: during bolting; right: when the bolted connection has been completed)

When a bolting process has been completed successfully (torque bolting: torque has been reached within the allotted time frame; torque-angle bolting: tightening angle has been reached, and the torque corresponding to the tightening angle is within the tolerance limit stored in the bolting application definition), the following message will be displayed including the parameters that have been reached (here: the generated torque):

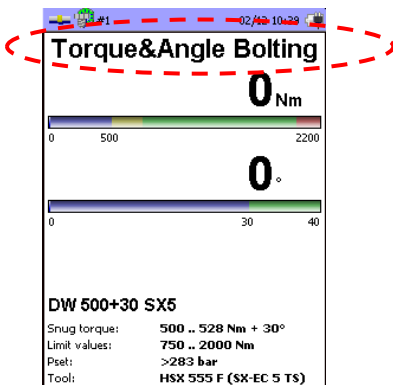

Example Torque-Angle Bolting Process

The bolting process is completed as described in chapter 0. While bolting is undergoing, the control unit will indicate the progress of the bolting process. The control unit indicates the increase in torque during torque bolting, while only initially indicating the increase in torque for torque-angle bolting processes. The control unit will indicate the increase of the tightening angle once the torque-angle bolting process has reached the snug torque:

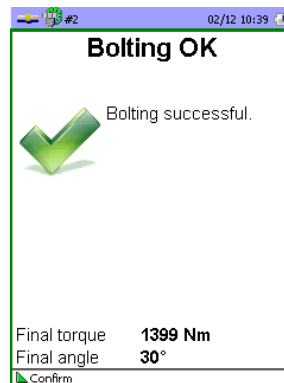

Before shifting the position of the hydraulic torque wrench, you should switch off the power pack by pressing the red switch on the side. You can place the hydraulic torque wrench onto the next bolting and bolt it down without the need to acknowledge the information on the control unit that has been reported to the control unit by the power pack. The active bolting counter is increased by one (the control unit keeps "counting" automatically). The evaluation of whether the bolting operation was completed properly is performed automatically by the system. The bolt data (operator's name, etc.) are also stored automatically for the next bolting unless they were changed (e. g. during a shift change).

If the system discovered an error during the bolting process, it will issue a corresponding error message.

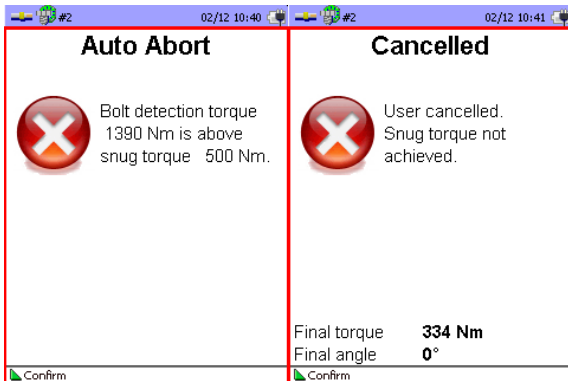

Example on the left: Tightened bolt; on the right: Abort by user

This may happen, for instance, if the user tries to retighten an already tightened bolt or inadvertently let go off the "automatic" button during the automatic bolting process. Such an error message must always be acknowledged on the control unit, the bolting number is not increased by one automatically, and the bolting process can be repeated.

### 11.4.1. Loosening

To loosen bolts with the control unit connected, proceed in the same way as you would without the control unit connected as described in chapter 0. The control unit will display the following screen:

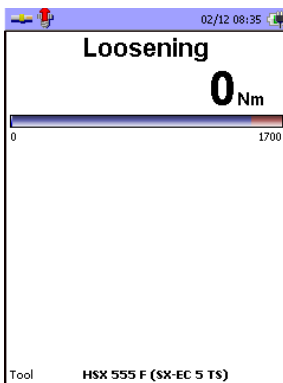



## 11.5. Additional features of the control unit

### 11.5.1. User data input

1. To modify the data that was entered after the pressure adjustment (e. g. operator's name during a shift change), you can open the menu "Enter Data" manually as well. The control unit must be connected with the power pack for this purpose! The power pack must be connected to the mains supply! Press the button  on the control unit to call up the main menu of the control unit.



2. Use  /  to select the child menu "Enter Data" and press  to confirm your selection.

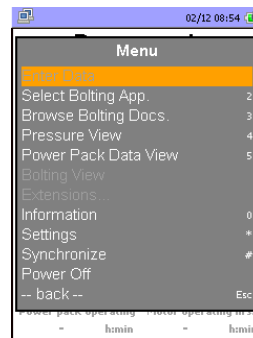

3. You can use the child menu "Enter Data" to enter data about the bolting in six free text fields (e. g. operator's name, operator's ID, workpiece designation, etc.) that complement the field "Bolt no.", which will always remain in place, or overwrite existing entries.

The illustration below shows that the user did not create another field apart from the field "Bolt no."

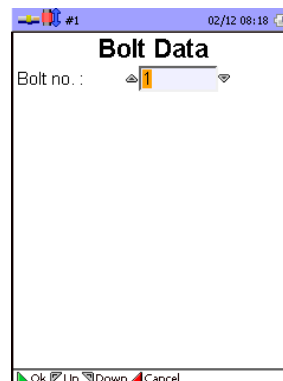



Use the included PC software application to define the number and designation of the fields. The control unit does not allow you to make any changes to the field names. All you can do is enter data in the fields provided you selected a bolting application beforehand.

### 11.5.2. Viewing documentation and data

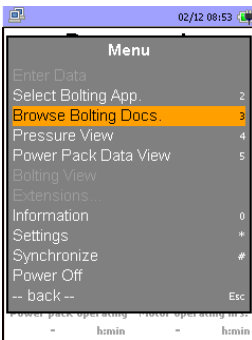
The submenu "Browse Bolting Docs." provides a list of the completed bolting operations. To open this menu, select the submenu "Browse Bolting Docs." in the main menu.



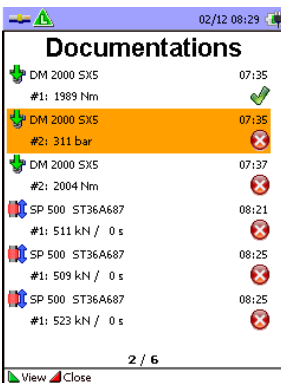

To view a documentation, browse through the submenu "Browse Bolting Docs." using the buttons  /  and select the highlighted record by pressing .

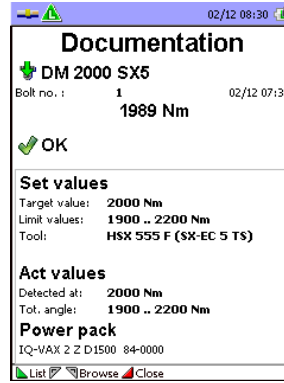

The record contains all data relating to this bolting operation including date, recorded pretensioning force / recorded torque or snug torque and tightening angle, tensioner / hydraulic torque wrench used, bolting designation, etc.



Use the buttons  /  to navigate to the next or the previous record in the detailed view.

If no data are available, the following message will appear:

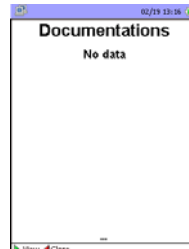

### 11.5.3. Viewing power pack data

The submenu "Power Pack Data View" allows you to view the data of the power pack that is connected to the control unit. To open this menu, select the submenu "Power Pack Data View" in the main menu.

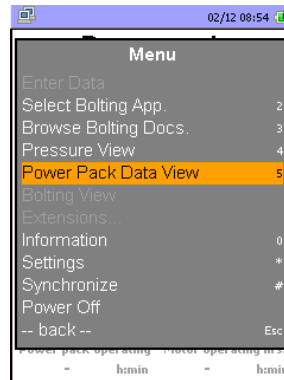

The control unit shows the current data of the power pack:

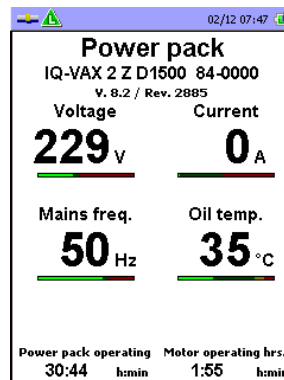

### 11.5.4. Viewing data about the control unit

To open this menu, select the submenu "Information" in the main menu.

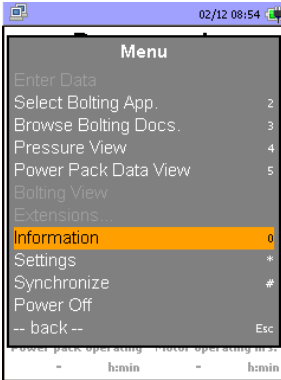

The submenu "Information" lets you view all data relating to the control unit.



Exit the menu by pressing .





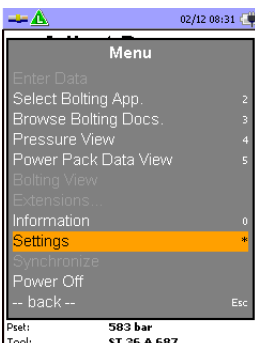

### 11.5.5. Modifying settings



You can open the submenu "Settings" by pressing  in the main menu.





You can alter the following settings in the submenu "Settings": Language, temperature unit (degree Centigrade / Fahrenheit), and time zone; if using the control unit on a network, you can also adjust the IP address and the netmask.



1. Press either of the two buttons  /  on the control unit to toggle between language, temperature unit and the netmask and IP address input fields.
2. Change language and temperature unit using  and  /  and .
3. Change the IP address and the netmask using the numeric keys on the control unit:

Select "IP Address" / "Netmask" using  / . The status bar of the display will show the icon **123**. The buttons on the control unit have now been switched to numeric mode. Enter IP address / netmask.

4. Press  to confirm your entries.
5. Press  to cancel the process.

### 11.6. Powering down the control unit

To power down the control unit, select the submenu "Power Off".

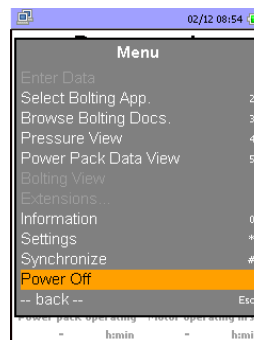

### 11.7. Data exchange between PC and control unit

You will not be able to use the control unit with the power pack unless you have previously transferred bolting application data from the PC to the control unit.

Only the included PC software application allows you to create or modify bolting applications. This ensures that the operator will not be able to manipulate the parameters of the bolting application later on.

Connect the docking station to your PC either directly using a network cable or with the included network adapter.

Both cases require that an administrator set up a network connection. You will find the associated documentation on the CD in the folder "Docu."

When using the included network adapter (see included installation CD), you can connect the control unit to an available USB port on your PC.

If you want to connect the control unit via a network, connect the control unit directly to the network you want to use using a network cable.

In each case, you must assign a valid IP address to the control unit or the network interface. Consult your network administrator if necessary.

#### Performing data exchange

1. Insert the control unit into the docking station.
2. If the control unit is connected properly to the PC via the docking station, the icon marked in the illustration below will confirm the correct connection.

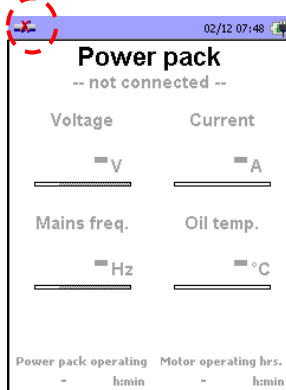

3. You can now synchronise the control unit with the PC. During this process, the bolting documentations (data of the completed bolting operations) will be

transmitted to the database on the PC; at the same time, the selected bolting application definitions will be transferred from the PC to the control unit (see chapter 0).

To start the process, select the submenu "Synchronize" and press .

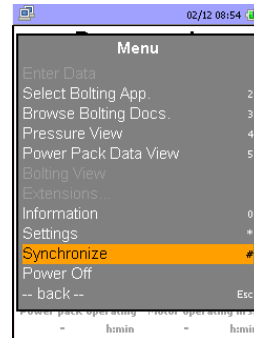

The following message will be displayed during synchronisation:



The following message will appear if the control unit is not properly connected to the PC or the synchronisation application is currently not running on the PC (see also 0 tion "BE32Sync.exe" on your PC).

## 12. CREATING/ MANAGING BOLTING APPLI- CATIONS



If this happens, you need to establish the connection or launch the synchronisation application "BE32Sync.exe" on your PC.

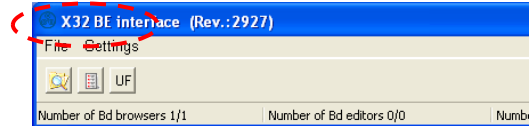

*Buttons to open additional browsers and editors*

3. If necessary, open additional bolting definition browsers, browsers for bolting definition lists or the "Editor for standard user fields." Click the correspond-ding icon to do so.

The status bar indicates the current number of open browsers/editors.

4. To control the browsers and editors, move the cursor into the workspace of the browser or editor.
5. Right-click to open the "context menu."

## 12. CREATING/ MANAGING BOLTING APPLI- CATIONS

You create and manage bolting applications by using the PC software application "BE32.exe."

1. Install software and driver as described in the user's guide. You will find the user's guide and the software application on the software CD that is included with your control unit.
2. Launch the application "BE32.exe" (Start/Run).

The main window "X32 BE Interface", which is comprised of the "Bolting definition browser" and the "Browser for bolting definition lists", appears:

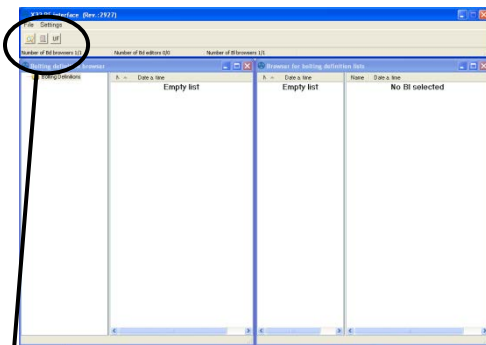

### 12.1. Creating user fields

You can use the editor for standard user fields to define up to six free text user fields of your choice for your control unit. While using the unit for bolting, the operator can enter additional information into the fields that have been created with the help of this editor.

1. Open the editor for standard user fields by clicking on the icon "UF."

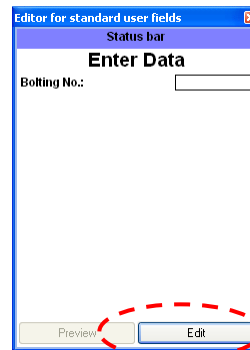

2. If necessary, switch to editor view by pressing the button "Edit."
3. Enter headings for the fields:

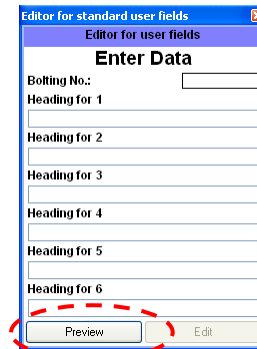

4. Switch to preview mode by pressing the "Preview" button and verify your entries.

This allows you to check how the text you entered will be displayed on the control unit.

You can later store the template you created in a bolting application (see 0 12.2. Creating/editing).

The user fields created in the example shown here are "Bolting", "Operator", "Flange number" and "Tower number." These specifications are stored during bolting along with the bolt data.

## 12.2. Creating/editing bolting applications

The bolting definition browser lets you create and manage bolting applications. You can also create a directory structure which allows you to store your individual bolting applications (e. g. sorted by machine types).

1. If necessary, open the bolting definition browser with a click on the "Browser with magnifier" icon:

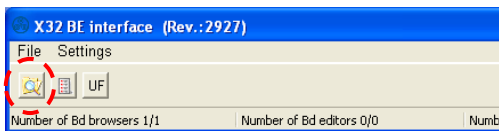

The editor opens:



2. Right-click to open the context menu.
3. Select "Create bolting application" and enter a name.

The bolting application shows up on the list.

A bolting application remains invalid until all data fields have been completed correctly and in full. In the mean- time, the following icon will remain in front of the name of the bolting application:



When the bolting application has been created pro-perly and in full, the name of the bolting application will be preceded by the associated bolting mode.

4. A double click on the bolting application (or selecting it using the context menu) will open the "Bolting definition editor."

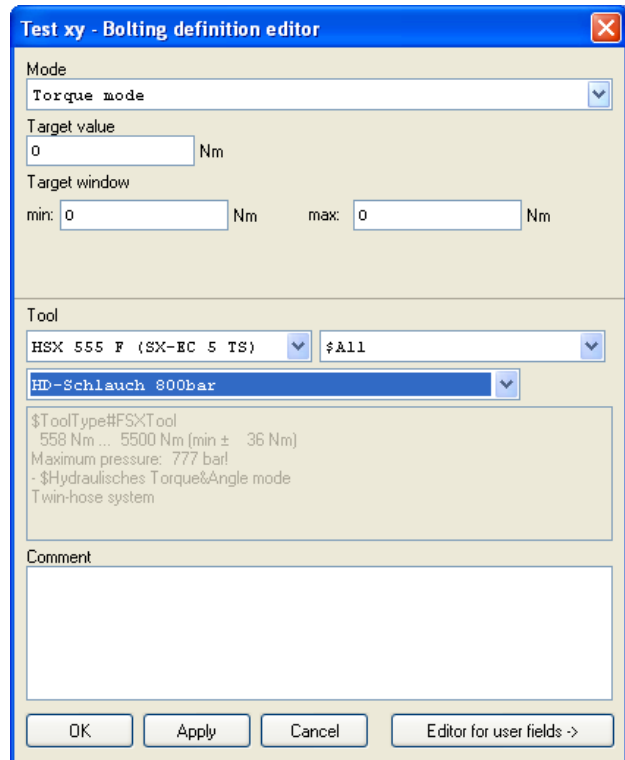

5. Enter the bolting application parameters in the editor window including the required pretensioning force, the tool used, etc.

Aside from tensioner applications, you can also create torque/angle bolting applications. The control unit is also designed to work with other power packs that are used to create bolted connections by turning.

When using a bolting application in combination with an IQ TAX 1-1500 power pack, make sure you are creating this bolting application in tensioner mode. These power packs are only suitable for processing data used for tensioners.

6. If needed, bring up the "Editor for user fields" by clicking the associated button. (For more information, see 0 12.1. Creating user fields).

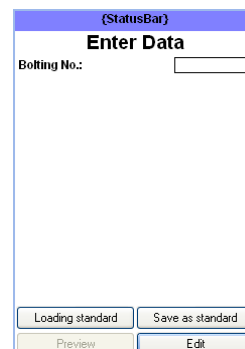



7. If you wish to store the user field definition as default (as a template for other bolting applications), click on the button "Save as standard."
8. If standard user field definitions have already been created, click on "Loading standard" to load the standard definition.

### 12.3. Creating bolting definition lists

You can use the browser for bolting definition lists to compile application-specific lists that are based on the bolting applications you created.

1. Open the browser for bolting definition lists by clicking on the "List" icon.
2. Right-click to open the context menu.
3. Select "Create bolting definition list" and enter a name.
4. Drag and drop the desired bolting applications from the browser for bolting definition lists to the selected list.

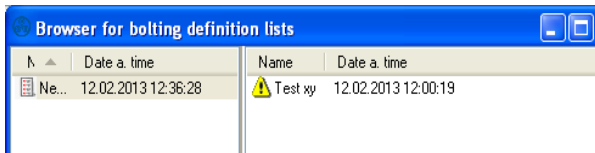

If you apply the default setting, all available bolting definition lists will be transmitted to the connected control unit during synchronisation. Note, however, that any invalid bolting applications that may be contained in these bolting definition lists will not be included in the transfer!

### 12.4. Managing documentation data

The bolting documentations stored in the control unit will be saved to the PC database every time you sync control unit and PC.

The bolting documentations will be erased from the control unit after each successful transmission.

Use the application "DrExplorer.exe" to view and manage the bolting documentations that are stored on the PC. This application displays the bolting documentations in a table and allows you to filter, sort and export them.

1. Launch the application "DrExplorer.exe" (Start/Run).

The application window opens:

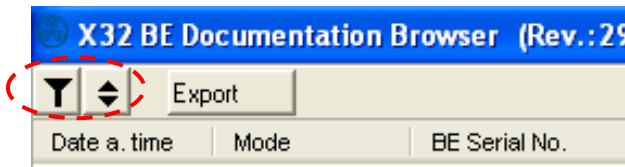

2. Click on the icons shown above to select the functions Filter or Sort.
3. Right-click to open the context menu.

The dialog box that lets you define a filter or a sort sequence opens. You can enter a maximum of five filter and sorting criteria.

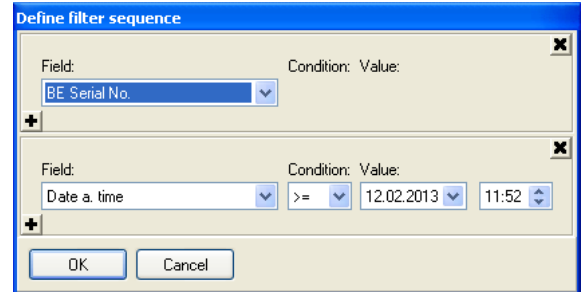

*The filter in this example sorts results by the serial number of the control unit and date/time*

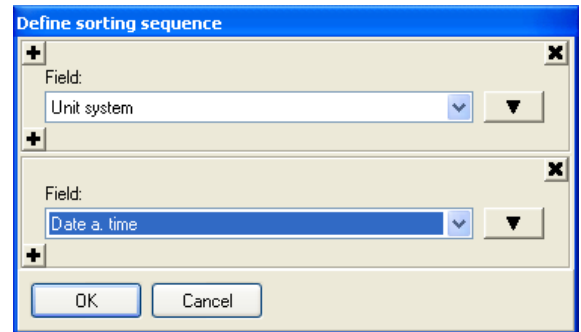

*In this example, the results are sorted first by bolting mode (descending) and then by date/time (ascending)*

To export data, click on the Export icon:

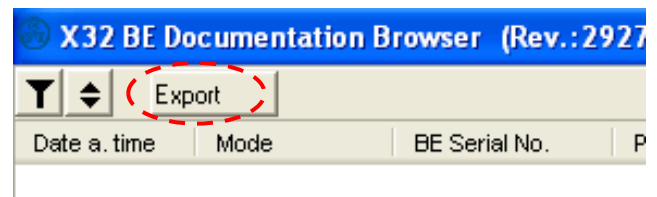

In the following dialog box,

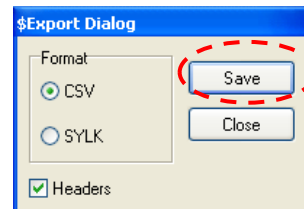

you can define the file format.

After selecting the file format, click on the Save button marked in the illustration above.

The following dialog box appears:

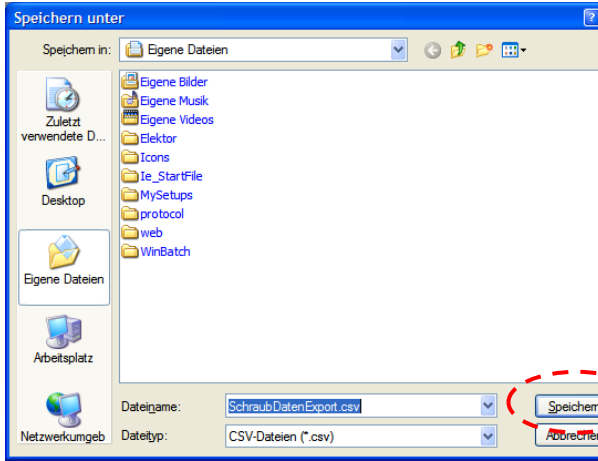

Use this dialog box to specify the file name and the path under which you wish to save the file and finish saving by clicking on the Save button that is marked in the illustration above.

Only the data previously selected by the filter will be exported. The data is transferred in the order that you specified by applying your sorting criteria.

**13.ERROR MESSAGES**

**Internal errors**

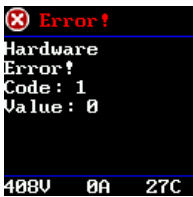

Example of an internal error message

Once connected via the power plug, the power pack will perform a self-test. The self-test starts by displaying internal error messages which will disappear once the test has been completed successfully.

While the self-test is in progress, the remote control may show error messages for a brief period of time. If these error messages are still indicated when the self-test is completed, the power pack needs to be turned in for service.

**Clear text error messages**



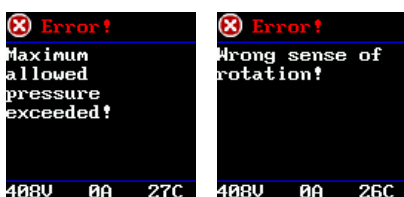





Errors that can be corrected by the user are displayed as clear text messages:



Examples of user errors

**14. REMOTE CONTROL DISPLAY**

The status bar may display the following icons. The green LED will be on at the same time.

-  Menu
-  Tensioner mode without automatic repumping
-  Tensioner mode with automatic repumping
-  Error
-  Pressure adjustment mode enabled (1,500 bar tensioner mode) or calibration required (800 bar bolting mode)
-  Torque mode
-  Loosening mode
-  Torque-angle bolting mode

The following icon may be displayed along with the red LED.

-  Connected to PC or control unit

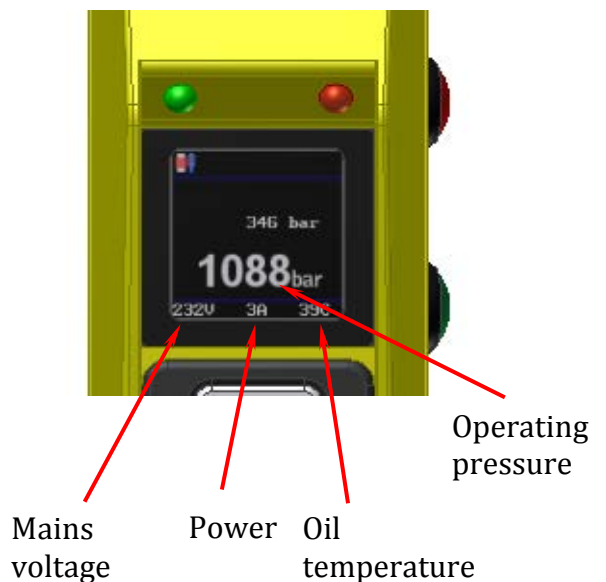

## 15. LED ON THE REMOTE CONTROL



Blinking frequency	Function of IQ VAX D1500 with control unit in tensioner mode up to 1,500 bar	Function of IQ VAX D1500 without control unit in tensioner mode up to 1,500 bar
Green indicator light is lit permanently	Power pack is set to tensioning mode. Function 1: Power pack is ready for tensioning (you may still have to set the pressure that matches the bolting application!) Function 2: The tensioning process was completed correctly, i. e. the documented pressure stayed within the tolerance limit that was specified by the control unit.	Power pack is set to tensioning mode. Function 1: Power pack is ready for tensioning (you may still have to set the pressure that matches the bolting application!) Function 2 ( <b>only with Automatic Repump Mode disabled</b> ): The tensioning process was completed correctly, i. e. the set pressure was delivered by the power pack.
Green indicator light is blinking slowly	Power pack is set to pressure adjustment mode.	Power pack is set to pressure adjustment mode.
Green indicator light is blinking rapidly	Power pack is set to tensioning mode. Rapid blinking is always an indication of an ongoing process, e. g. the power pack is starting up or pressure is being built up during the tensioning process.	Power pack is set to tensioning mode. Rapid blinking is always an indication of an ongoing process, e. g. the power pack is starting up or pressure is being built up during the tensioning process.
Red indicator light is blinking	Tensioner is being relieved.	Tensioner is being relieved.
Red and green indicator light are blinking alternately	An error has occurred.	An error has occurred.
Red and green indicator light come on permanently at the same time	Tensioning is enabled. Target pressure was reached. Bolt can be added. Automatic repumping may occur in the meantime!	<b>In Automatic Repump Mode only:</b> Tensioning is enabled. Target pressure was reached. Bolt can be added. Automatic repumping may occur in the meantime!
Red indicator light is lit permanently, green light is blinking	Power pack repumps automatically.	<b>In Automatic Repump Mode only:</b> Power pack repumps automatically.

Blinking frequency	Function of IQ VAX with control unit in standard mode up to 800 bar	Function of IQ VAX without control unit in standard mode up to 800 bar
Green indicator light is lit permanently	Bolting system is set to tightening mode. Function 1 following calibration if calibration was OK Function 2 following the bolting process if bolting process was OK and the documented pressure stayed within the tolerance limit that was specified by the control unit.	Bolting system is set to tightening mode. Function 1 following calibration if calibration was OK Function 2 following the bolting process if bolting process was OK
Green indicator light is blinking slowly	Bolting system is set to tightening mode. While bolting system is starting up. Calibration has not yet been performed.	Bolting system is set to tightening mode. While bolting system is starting up. Calibration has not yet been performed
Green indicator light is blinking rapidly	Bolting system is set to tightening mode. Rapid blinking is always an indication of an ongoing process inside the bolting system, e. g. the power pack is starting up or the bolting process is in progress.	Bolting system is set to tightening mode. Rapid blinking is always an indication of an ongoing process inside the bolting system, e. g. the power pack is starting up or the bolting process is in progress.
Red indicator light is blinking slowly	Bolting system is set to loosening mode. Calibration has not yet been performed.	Bolting system is set to loosening mode. Calibration has not yet been performed.
Red indicator light is blinking rapidly	Bolting system is set to loosening mode. Rapid blinking is always an indication of an ongoing process inside the bolting system, e. g. the power pack is starting up or the loosening process is in progress.	Bolting system is set to loosening mode. Rapid blinking is always an indication of an ongoing process inside the bolting system, e. g. the power pack is starting up or the loosening process is in progress.
Red indicator light is lit permanently	Bolting system is in loosening mode after calibration is complete and calibration is OK	Bolting system is in loosening mode after calibration is complete and calibration is OK
Red and green indicator light are blinking alternately	An error has occurred	An error has occurred



# 16. MEMBRANE KEYBOARD OF THE CONTROL UNIT











## 17. DISPLAY OF THE CONTROL UNIT

The connection status can be indicated by the following icons:

-  Control unit not connected to the power pack
-  Control unit connected to the power pack
-  Control unit has data link to PC

The power pack status can be indicated by the following icons:

-  Tensioner mode
  -  No bolting application transmitted
  -  Torque mode
  -  Loosening mode
  -  Torque/angle bolting mode
  -  Calibration required
- Indication of the current bolting number

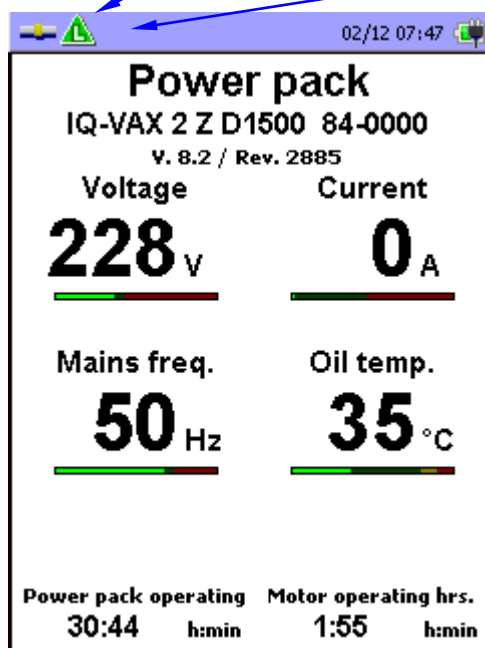

Battery charging status / mains supply

Footer

## 18. MAINTENANCE INSTRUCTIONS



**Warning!**  
Dangerous electrical voltage.

Unexpected start-up as a result of inadvertent actuation.  
**Pull the power plug before adjusting any settings and prior to servicing or repairs.**

Observe the following points:

Check the oil level of the power pack on a regular basis, but at least every time before you start working.

Change the hydraulic oil every 150 hours of operation, but no later than every 12 months.

You can find the operating hours in the "Information" menu on the remote control.

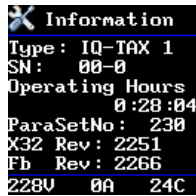

Keep the couplings and the nipples on the power pack, on the hydraulic hoses and on the tensioners clean. Use a cloth to clean the couplings and nipples before connecting them.

Seal the couplings and nipples with sealing caps prior to transport and storage.

## 19. INSTRUCTIONS ON DISPOSAL

Dispose of the power pack as required by local regulations.



### Attention!

This symbol points out that the product must not be disposed of with regular household waste as specified in the WEEE directive (Waste Electrical and Electronic Equipment Directive, 2002/96/EC) and national laws.

**Dispose of this product at an authorised waste collection facility. Return the product if, for instance, purchasing a similar product or take it to a waste collection facility that is authorised to recycle waste electrical and electronic equipment.**

**Turn to your local administration office, your public waste disposal authority, a facility that is authorised to dispose of waste electrical and electronic equipment or your waste management company.**



... a successful  
connection!

Maschinenfabrik Wagner GmbH & Co. KG  
Birrenbachshöhe · 53804 Much · Germany

**Tel. national:** (02245) 62-0  
**Fax national:** (02245) 62-66  
**Phone international:** +49 (0)2245 62-10  
**Fax international:** +49 (0)2245 62-22

info@plarad.com · [www.plarad.com](http://www.plarad.com)

Reproduction and copying of this volume, in whole or in part,  
is permissible only with express written permission. Subject to  
amendment. We take no responsibility for printing  
errors or inaccurate information.  
Last update: 09/2016

D20-000-1-02400

2\_BA\_IQ-VAX\_DR-DW\_X32\_GBR\_2.0\_69418