

Operating instructions

Pneumatic nutrunner

DP2power



PLARAD[®] 
Torque & Tension Systems

**Read the manual carefully before use!
Keep for future use.**

Maschinenfabrik Wagner GmbH & Co. KG

Birrenbachshöhe 17

53804 Much

GERMANY

Telephone: +49 2245 62-0

Fax: +49 2245 62-22

Email: info@plarad.de

Internet: www.plarad.de

Translation of the original operating instructions

pA# 83641, 1, en_GB



Information about this manual



This manual enables the safe and efficient handling of the pneumatic nutrunner DP2power (referred to in the following as “nutrunner”).

The manual is a component of the nutrunner and must be kept in its immediate vicinity so that the user can access it at any time.

The user must have read and understood this manual prior to commencing any tasks. A basic prerequisite for ensuring that work is performed safely is compliance with all safety warnings and guidelines in this manual. In addition, the local accident prevention regulations and general safety provisions for the nutrunner’s area of application apply.

Illustrations in this manual serve to provide a basic understanding and may differ from the actual design.

Versions

This manual applies to the following nutrunners:

DP2power	with angular gearbox
DP2power-05	DP2power-05W
DP2power-10	DP2power-10W
DP2power-20	DP2power-20W
DP2power-30	DP2power-30W
DP2power-36	DP2power-36W
DP2power-48	DP2power-48W
DP2power-80	DP2power-80W

Other applicable documents



The following documents must be observed in addition to this manual:

- Rating plate
- EU declaration of conformity
- Torque chart
Individual assignment of fastening operations and torques to the torque levels of the supplied nutrunner
- Certificates (option)
- Technical data sheet

Compressed air supply

The service unit for compressed air, which is required in order to operate the nutrunner, is not included in the scope of delivery for the nutrunner and must be provided by the operator.

The illustrations of a service unit for compressed air in this manual are examples. These examples describe only the basic structure and function of a service unit for compressed air. The actual version may deviate from these illustrations.



Always note the operating instructions for the service unit for compressed air in use.

Copyright

This manual is protected by copyright.

The transfer of this manual to third parties, duplications of any kind and form – including excerpts – as well as the utilisation and/or communication of the manual's contents are not permitted without the written consent of Maschinenfabrik Wagner GmbH & Co. KG, except for internal purposes. Infringements will result in liability for damages. Maschinenfabrik Wagner GmbH & Co. KG reserves the right to assert additional claims.

Maschinenfabrik Wagner GmbH & Co. KG is the copyright holder.

Further development of the manual

This manual was compiled with great care. If you notice any errors, have any questions or identify any inconsistencies, please notify us in writing. Your suggestions for improvement will help us design a user-friendly manual.

Manufacturer

Maschinenfabrik Wagner GmbH & Co. KG

Birrenbachshöhe 17

53804 Much

GERMANY

Telephone: +49 2245 62-0

Fax: +49 2245 62-22

Email: info@plarad.de

Internet: www.plarad.de

PLARAD[®] service

Information about PLARAD[®] service and authorised PLARAD[®] partners:

- www.plarad.de



Table of contents

1	Unpacking	7
2	Getting to know the nutrunner	9
2.1	Illustration of the nutrunner.....	9
2.2	Brief description.....	10
2.3	Rating plate.....	11
2.4	Nutrunner controls.....	11
2.5	Service unit for compressed air (provided by the operator).....	12
2.6	Accessories.....	13
2.7	Offset head accessories.....	14
2.7.1	Illustrations.....	14
2.7.2	Using an offset head.....	15
2.7.3	Maintaining an offset head.....	16
3	Before you begin – safety	19
3.1	Symbols in this manual.....	19
3.2	Symbols on the nutrunner.....	21
3.3	Intended use.....	23
3.4	Misuse.....	23
3.5	Residual risks.....	24
3.5.1	Mechanical dangers.....	24
3.5.2	Noise and ergonomics.....	26
3.6	Operator's obligations.....	29
3.7	Who is permitted to use the nutrunner?.....	30
3.8	Personal protective equipment.....	31
3.9	Environmental protection.....	33
4	Determining the bolting process	34
5	Preparing the nutrunner	35
6	Supplying with energy	37
6.1	Supplying pneumatic energy.....	37
6.2	Checking the filter.....	37
6.3	Connecting the nutrunner to the compressed air.....	38
6.4	Setting the oil mist lubricator.....	38
6.5	Setting the torque.....	38
7	Bracing the reaction arm	40
8	Tightening	42
9	Loosening	45
10	Performing maintenance	47
10.1	Maintenance schedule.....	47
10.2	Maintenance by the user.....	49
10.3	Draining condensate.....	50
10.4	Cleaning the filter.....	50
10.5	Filling the oil mist lubricator.....	51

10.6	Having service tasks performed by the manufacturer.....	52
11	Troubleshooting.....	54
11.1	Identifying faults.....	54
11.2	Performing troubleshooting.....	55
12	Disposing of the nutrunner.....	56
13	Technical data.....	57
14	Index.....	60
	Appendix.....	63



1 Unpacking

Delivery

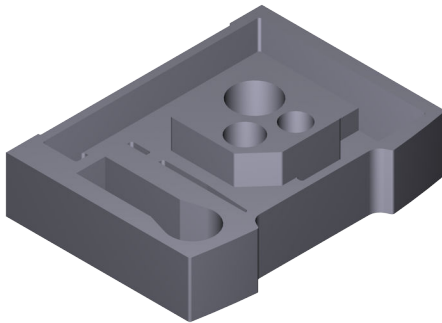

Fig. 1: Foam inlay

The nutrunner is delivered in a plastic transport case together with the other items in the scope of delivery.

The transport case is packed in a cardboard box upon delivery.

The transport case is fitted with a foam inlay. The recesses in the inlay enable precision storage of the scope of delivery.

Checking the delivery



Check the delivery for transport damage and ensure it is complete immediately upon receipt. If it is incomplete or if there are defects, note the extent of the damage on the transport documents and lodge a complaint immediately.

Scope of delivery

The scope of delivery includes:

- Transport case
- Nutrunner
- Reaction arm
- Circlip pliers
- Circlip
- O-ring
- Document folder
 - Operating instructions
 - Torque chart
 - EU declaration of conformity

Options:

- Trolley
- Impact wrench socket
- Test certificate for torque chart
- Reaction arm versions
- Offset gears
- Any accessory ordered



*Technical data sheet is available online at:
<https://www.plarad.de/download-center.html>*

Handling packaging material

The individual packages are packed according to the expected transport conditions. Only environmentally friendly materials are used for the packaging.

The packaging should provide protection against transport damage, corrosion and other damage. For this reason, do not destroy the packaging and do not remove it until shortly before use.

Dispose of packaging material in accordance with the applicable statutory provisions and local regulations.



ENVIRONMENT!

Danger to the environment due to incorrect disposal!

Packaging materials are valuable raw materials and, in many cases, can be further utilised or appropriately reconditioned and recycled. Incorrect disposal of packaging materials can be hazardous to the environment.

- Reuse pallets.
- Dispose of packaging materials in an environmentally sound manner.
- Observe the locally applicable disposal regulations. If necessary, engage the services of a specialist company with regard to disposal.

Transport and storage

Always store and transport the nutrunner in the transport case.

Set the direction of rotation to the middle position (transport position) ↺ *'Direction of rotation setting' on page 11.*

Do not take the nutrunner out of the transport case until shortly before use.



2 Getting to know the nutrunner

2.1 Illustration of the nutrunner

DP2power



Fig. 2: Overview of DP2power nutrunner

- | | | | |
|---|-------------------------------|---|---------------------|
| 1 | Square drive (tool holder) | 6 | Pistol grip |
| 2 | Reaction arm serration | 7 | Compressed air port |
| 3 | Safety swivel joint | 8 | Ventilation slot |
| 4 | Drive motor | 9 | Trigger |
| 5 | Direction of rotation setting | | |

DP2power with angular gearbox

Fig. 3: Angular gearbox

- | | | | |
|---|----------------------------|----|-------------------------------|
| 1 | Square drive (tool holder) | 7 | Drive motor |
| 2 | Reaction arm serration | 8 | Direction of rotation setting |
| 3 | Safety swivel joint | 9 | Handle |
| 4 | Angular gearbox | 10 | Compressed air port |
| 5 | Handle | 11 | Trigger |
| 6 | Safety swivel joint | | |

2.2 Brief description

The nutrunner is a hand-held tool for tightening and loosening bolted connections in a dry environment.

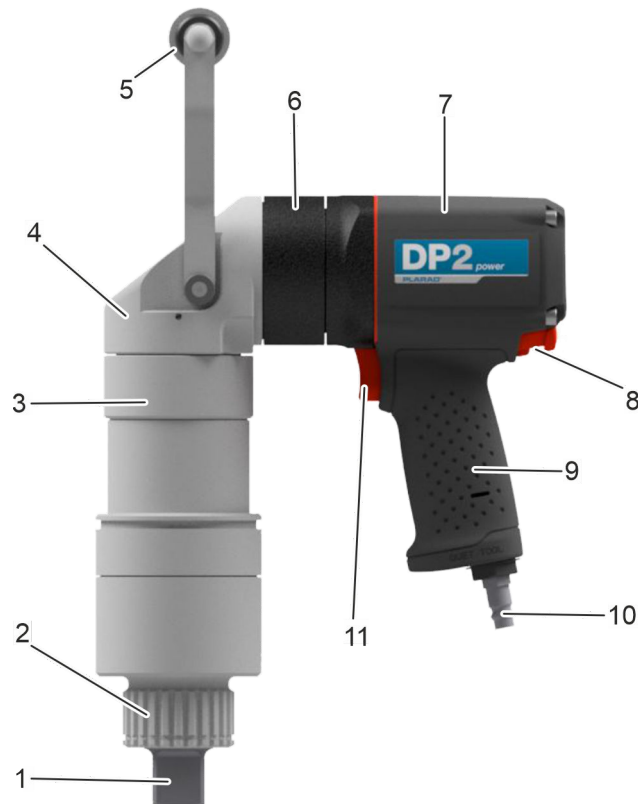
The nutrunner is powered pneumatically using compressed air.

An individually adjustable reaction arm is used to brace the tool against the torque.

The desired torque can be selected by adapting the pneumatic pressure.



2.3 Rating plate

Nutrunner

The following data is inscribed on the rating plate:

- Name of the manufacturer including their full address
- Machine designation
- Type designation
- Article/serial number
- Maximum torque
- Maximum operating pressure
- Year of manufacture
- Weight
- CE marking/UKCA marking

2.4 Nutrunner controls

DP2power

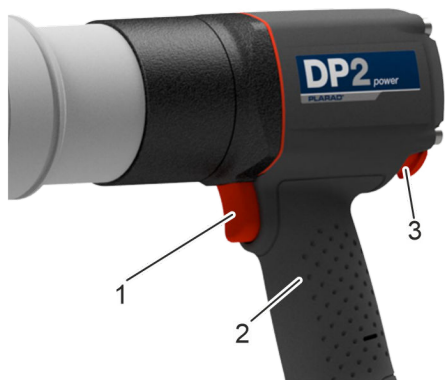

Fig. 4: DP2power controls

The nutrunner features the following controls:



- 1 Trigger
- 2 Pistol grip
- 3 Direction of rotation setting

Direction of rotation setting



Fig. 5: Direction of rotation setting

The direction of rotation can be changed with the aid of the direction of rotation setting (Fig. 5).

No.		Direction of rotation setting	Direction of rotation
1		Right-hand side is pressed.	Clockwise (CW) Tightening in clockwise direction
		Middle position	No rotation possible. Transport position
2		Left-hand side is pressed.	Anti-clockwise (CCW) Loosening in anti-clockwise direction

Pistol grip

The nutrunner can be gripped securely and carried by the pistol grip (Fig. 4/2). Ergonomic use of the trigger is possible.

Handle (with angular gearbox)

The handle (Fig. 3/5) offers an additional option for securely holding and transporting the nutrunner. The DP2power with angular gearbox comes with the handle as standard.

Trigger

The set fastening operation is initiated with the trigger (Fig. 4/1) and is executed for as long as the trigger is pressed.

Do not pulse!



Do not pulse!

(Press and release the trigger in quick succession)

Always execute the fastening operation in full. To this end, press and hold the trigger for the entire duration of the fastening operation.

2.5 Service unit for compressed air (provided by the operator)

Operation of the pneumatic nutrunner requires a compressed air supply, including a service unit for compressed air equipped with water separator (filter), pressure regulator, and oil mist lubricator.



The service unit for compressed air is not included in the scope of delivery for the nutrunner.

A service unit for compressed air must be provided by the operator.

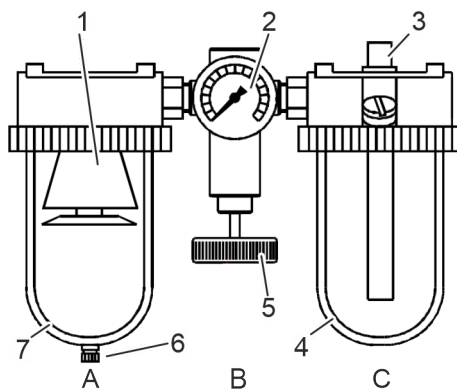

Fig. 6: Example, service unit for compressed air

- A Water separator, filter
- B Pressure regulator
- C Oil mist lubricator
- 1 Filter
- 2 Pressure display
- 3 Dosing screw for setting the oil quantity
- 4 Oil tank
- 5 Pressure adjustment
- 6 Condensate drain
- 7 Condensate tank

Air compressor system

Air compressor system requirements:

- Capacity of the air compressor system at least 1,000 l/min effective, constant
- Line pressure 6 bar, constant



Air compressor hose

Air compressor hose requirements:

- Maximum air compressor hose length between service unit for compressed air and nutrunner 3 m
- Minimum clear width 13 mm



Longer and thinner air compressor hoses adversely affect flow pressure and air throughput.

Water separator (filter)

Water separator and filter requirements:

- Air filter with 5 µm particle separation
- Condensate separation

Oil mist lubricator

The oil mist lubricator supplies fine oil mist to the compressed air, thereby effecting continuous, reliable lubrication of the drive motor.

Oil mist lubricator requirements:

- The minimum operating pressure depends on the service unit for compressed air.
Note the manufacturer's specifications.
- Oil quantity up to 2 bar: 1 drop per minute
- Oil quantity above 2 bar: 2 drops per minute
- Always top up the oil in a depressurised state.

2.6 Accessories

The following accessories are available for ordering together with the nutrunner and may be included in the delivery:

- Impact wrench socket with circlip (spring clip)
- Reaction arm with circlip
Special reaction arm
Extensions
- "Torque Control TC1" mobile measuring unit
- Impact wrench sockets in various designs
- Certificate
Technical, more detailed supplement to the torque chart
- Offset gears for long studs

Special accessories



Contact PLARAD[®] service.

2.7 Offset head accessories

2.7.1 Illustrations

Versions

Three versions of PLARAD[®] offset heads are available.

For more details, visit <https://www.plarad.de/download-center.html>

Illustration example STX

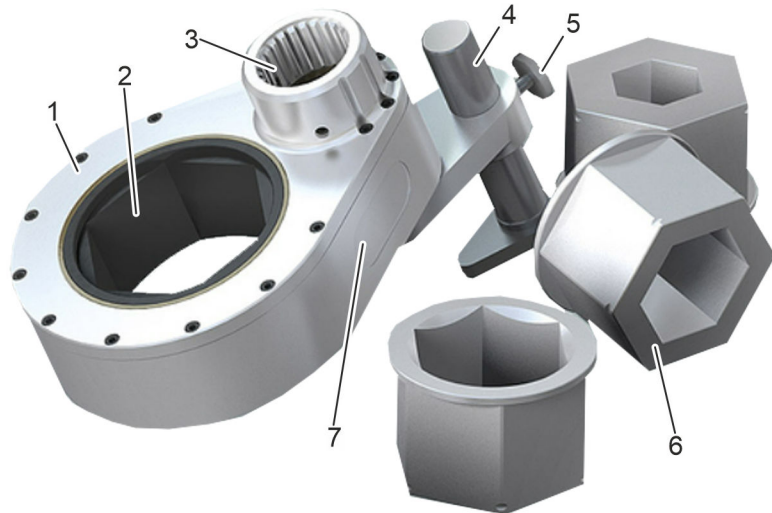

Fig. 7: Illustration example STX

- 1 STX offset head
- 2 Hexagon insert
- 3 Square drive holder
- 4 Offset head brace
- 5 Locking screw
- 6 Hexagon reducer pieces
- 7 Rating plate

Brief description

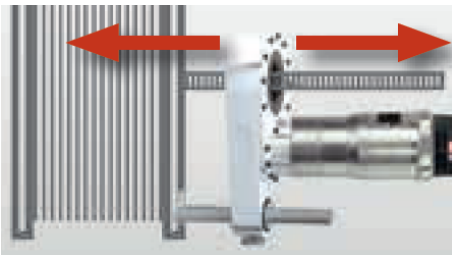

Fig. 8: Example

Offset heads let you perform bolting operations in spaces that are too small to accommodate a nutrunner directly above the bolt. The nutrunner's square drive and hexagon insert for bolting are off-set to one side.

Offset heads facilitate screwing nuts along long threaded spindles (Fig. 8).

Technical data sheet



Technical data sheet is available online at:
<https://www.plarad.de/download-center.html>



Rating plate

The rating plate lists the following data:

- Name of the manufacturer including their full address
- Type designation
- Article/serial number
- Maximum torque
- Year of construction
- Weight
- Gear reduction

Conversion formulas for rotation angle

The rotation angle of the square drive and the hexagon insert differ by multiplier x.

Multiplier x is specified for each offset head:

- Rating plate
- Technical data sheet

2.7.2 Using an offset head

Personnel: ■ Qualified nutrunner personnel

Protective equipment: ■ Protective work clothing

- Safety shoes

Further details ↪ *Chapter 5 'Preparing the nutrunner' on page 35.*

Preparing the offset head

1. ➤ Choose an offset head suitable for the bolting operation.

2. ➤ If necessary, insert a hexagon reducer piece into the offset head's hexagon.

3. ➤ Insert the offset head's brace. Securely tighten the offset head brace's locking screw.

If there are bracing panels available, use these to brace the nutrunner.

4. ➤ Attach the offset head to the bolted connection.

Offset head brace

5. ➤ Brace the offset head. To do so, loosen the locking screw, position the offset head's braces on a suitable bracing surface and securely tighten the locking screw.

6. ➤ Attach the nutrunner's square drive.

⇒ The offset head is ready to perform bolting.

2.7.3 Maintaining an offset head

Improperly performed maintenance tasks



WARNING!

Danger of injury from improperly performed maintenance tasks!

Improper maintenance can cause serious injuries and significant property damage.

- Ensure sufficient assembly space prior to commencing the tasks.
- Ensure that the assembly site is clean and tidy. Loosely stacked or randomly scattered components and tools may cause accidents.
- With regard to maintenance tasks, only allow “Clean” and “Check for damage” to be performed by the user.
- Have all repairs performed by the manufacturer.
- Use only PLARAD® original parts.

Maintenance tasks

If routine checks reveal increased wear, shorten the requisite maintenance intervals according to the actual signs of wear. If you have questions about maintenance tasks and intervals, contact PLARAD® service.

Interval	Maintenance task	Personnel
Before and after every use	<ul style="list-style-type: none"> ■ Clean. ■ Check surfaces, warning symbols and pictograms for damage. ■ Check all components for damage and correct operation. 	User
Every month if used frequently	If there are any grease nipples, lubricate with Molykote LT165 or Molykote BR2.	User
Once a year	If there are any grease nipples, lubricate with Molykote LT165 or Molykote BR2.	PLARAD® service

Accessories, spare parts and wear parts

Spare parts must meet the technical requirements specified by PLARAD®. This is always ensured by original spare parts. A warranty can only be provided for original spare parts supplied by PLARAD®.

The installation or use of other spare parts can, under certain circumstances, adversely alter the specified design properties and, consequently, impair active or passive safety.

Any liability and warranty for damage resulting from the use of parts other than the original spare parts and accessory parts is excluded.

Have at least the following information about the nutrunner to hand to enable quick and easy processing:



- Client
- Serial number of offset head
- Desired spare part
- Desired quantity
- Desired mode of shipping

🔗 'PLARAD[®] service' on page 4

Maintenance of offset head by user

Personnel: ■ User

Perform the following maintenance steps before and after every use:

Cleaning

1. ➤



NOTICE!
Property damage due to improper cleaning!

Clean the offset head with a soft cloth. Never use strong cleaning agents, water, brushes, sharp-edged tools or high-pressure cleaners.



WARNING!
Fire hazard!

When using isopropyl alcohol, do not clean the offset head near ignition sources. Do not smoke. Let it evaporate.

Surfaces and markings

2. ➤

Check surfaces and markings for damage. Arrange for repairs if there is damage or illegible markings.

Check components

3. ➤

Check all components (offset head, head, detachable inserts, reducer pieces, offset head braces, safety splints, circlips etc.) for damage, deformation and correct operation. Arrange for exchange if there is damage.

4. ➤



WARNING!
Danger of injury from faulty offset head!

Do not use the offset head if it is faulty. Have it repaired immediately or have the faulty parts exchanged. Contact PLARAD[®] service.

Lubricate

If an offset head with grease nipples is used frequently, lubricate it once a month.

1. ➤

Squeeze Molykote LT165 or Molykote BR2 lubricant into the grease nipple with a grease gun.

2. ➤

Dispose of excess lubricant properly.

3. → Clean the offset head and work environment. Dispose of cleaning agents and excess lubricant in an environmentally sound manner.



3 Before you begin – safety

This section provides an overview of all safety aspects that are essential to the best possible protection of the personnel and the safe and trouble-free operation of the machine. Additional safety instructions for specific work tasks are contained in the sections regarding the individual life stages of the machine.

3.1 Symbols in this manual

Safety warnings

Safety warnings in this manual are indicated by symbols. Safety warnings are introduced by signal words that identify the severity of the hazard.



DANGER!

This combination of symbol and signal word indicates an immediate danger that will cause serious injury or death if not avoided.



WARNING!

This combination of symbol and signal word indicates a potential danger that may cause serious injury or death if not avoided.



CAUTION!

This combination of symbol and signal word indicates a potential danger that may cause minor or slight injury if not avoided.



NOTICE!

This combination of symbol and signal word indicates a potential danger that may cause damage if not avoided.



ENVIRONMENT!

This combination of symbol and signal word indicates potential pollution of the environment.

Safety warnings in step-by-step instructions

Safety warnings may apply to specific, individual instructions. Such safety warnings will be embedded in the list of instructions to maintain readability when executing the respective action. The signal words listed above are used.

Example:

1.  Loosen the bolt.

2. 



CAUTION!
Risk of getting trapped by lid!

Close lid carefully.

3.  Tighten the bolt.





Tips and recommendations



This symbol highlights useful tips and recommendations as well as information to help you use your equipment efficiently and without disruption.

Other markings

The following markings are used in this manual in order to highlight instructions, outcomes, lists, references and other elements:

Marking	Explanation
	Step by step instructions
	Outcomes of steps
	References to sections of this manual and to other applicable documents
	Lists without a fixed order
[Button]	Controls (e.g. buttons, switches), indicators (e.g. signal lamps)
'Display'	Display elements (e.g. on-screen buttons, assignment of function keys)



3.2 Symbols on the nutrunner

Illustration of DP2power



Fig. 9: Symbols

- 1 Nutrunner rating plate
- 2 Test badges

- 3 Direction of rotation setting
- 4 DP2power reaction arm

Illegible signage



WARNING!

Danger in the event of illegible signage!

Over time, signs and stickers can become dirty or be rendered unrecognisable by other means, such that hazards cannot be recognised and necessary operating instructions cannot be followed. This creates a danger of injury.

- Keep all safety notices, warnings and operating instructions in a clearly legible state at all times.
- Replace damaged signs and stickers immediately.

You will find the following symbols and information notices on the nutrunner:

Danger of crushing



Keep your hands away from areas bearing this warning.

There is a danger of body parts being crushed, pulled in or otherwise injured.

It is necessary to pay greater attention when performing work at the marked locations.

Follow the manual



Read the operating instructions prior to using the nutrunner.

Test badges



The test badges state the dates of the respective tests.

Date of the next PLARAD[®] inspection



For nutrunners with certificate:

Date of the last torque inspection

Direction of rotation setting



Directional arrows for loosening and tightening are indicated above the direction of rotation setting.

Reaction arm



The stated value indicates the maximum permissible torque for the reaction arm.



3.3 Intended use

The pneumatic nutrunner DP2power is a hand-held tool and may only be used for tightening and loosening bolted connections within the defined specifications (↪ *Chapter 13 'Technical data' on page 57*).

The nutrunner may only be used in a commercial setting and must not be used in a potentially explosive atmosphere.

Intended use includes compliance with all of the stipulations in this manual.



WARNING!

Danger of injury due to unadjusted torque levels!

The assignment of torque level (power level) and torque was determined on a test joint according to ISO 5393 (medium joint). If these values do not correspond to the actual fastening operation, this could result in injuries and damage.

- Determine the specific fastening operation and adjust the torque levels.

↪ *Chapter 4 'Determining the bolting process' on page 34*

3.4 Misuse

Any use beyond the intended use as well as any other use is considered misuse.



WARNING!

Danger in the event of misuse!

Misuse of the nutrunner can lead to dangerous situations.

- Never operate without the reaction arm.
- Do not operate the nutrunner as a driving motor.
- Do not operate the nutrunner in continuous operation.
- Never subject the nutrunner, bolts or accessories to loads exceeding the permitted torque.
- Never use to tighten pre-tightened bolts.
- Never operate unless properly braced.
- Never operate outside the permissible environmental conditions.
- Never carry out fastening operations that have not been considered in the torque chart.
- Do not “pulse” (briefly start up the nutrunner multiple times).

3.5 Residual risks

The following section outlines the residual risks potentially posed by the nutrunner even when it is used as intended.

To reduce the risks of injury and damage and to avoid dangerous situations, observe the safety warnings listed here and the safety warnings in the other sections of this manual.

3.5.1 Mechanical dangers

Moving components and rotational movements



WARNING!

Danger of injury due to moving components!

Moving components can cause serious injuries. There is a danger of being pulled in during rotational movements.

- During operation, do not reach into moving components or handle moving components. Do not touch the reaction arm, drive shaft, impact wrench socket, nut and other moving attachment parts.
- Do not switch on the nutrunner while carrying it. Set the direction of rotation to the middle position. Transport the nutrunner in the transport case.
- Never open the nutrunner.
- Wear tight fitting work clothing that resists tearing to some degree.
- Wear safety goggles.
- Protect long hair from being pulled in by rotating parts using a protective cap (hair net).

Incorrect bracing and overloading



WARNING!

Danger of injury from incorrect bracing, overloading, breakage!

Incorrect bracing or overloading of the nutrunner or individual components can result in serious injuries.

- Do not use the nutrunner if the fastening operation is not entirely clear.
- Note the torque chart.
- Check the reaction arm for visible damage prior to use. Do not use the reaction arm if it is damaged.
- Brace the reaction arm correctly ↪ *Chapter 7 'Bracing the reaction arm' on page 40.*
- Do not operate the nutrunner in continuous operation and do not use it as a drive unit.
- Use only PLARAD[®] original parts.



Reaction arm



The reaction arms are designed for a maximum permissible load.

Observe the stickers on the reaction arm and data sheet.

Crushing



WARNING!

Danger of crushing when bracing and due to high weight!

During operation, very strong forces act on the nutrunner, reaction arm, bracing surface and bolts. There is a danger of crushing between the reaction arm and bracing surface during tightening and loosening. The high weight of the nutrunner can cause crushing if it falls down.

- Handle the nutrunner with care and as intended.
- Give due consideration to the weight during transport and during all work.
- Have work performed only by persons who are physically capable of using the nutrunner safely despite its high weight.
- Do not reach between the reaction arm and bracing surface.
- Secure the nutrunner against falling when working at height.
- Wear safety shoes.
- Also wear an industrial safety helmet for overhead work.

Dirt and scattered objects



CAUTION!

Danger of injury from falling over dirt and scattered objects!

People may slip on or stumble over dirt and scattered objects. Falling may cause injuries.

- Always keep the work area clean.
- If objects are no longer needed, remove them from the work area and especially if such objects are at ground level.
- Mark unavoidable stumbling points with hazard tape.
- Keep handles and gripping surfaces of the nutrunner dry, clean and free of lubricants. Clean them immediately if they are dirty.

Impact wrench sockets



NOTICE!

Damage due to incorrect use of impact wrench sockets!

- Use impact wrench sockets suitable for the fastening operation without exception.
- Ensure a flawless, positive connection between the nutrunner, impact wrench socket, impact wrench, impact wrench socket, and bolt. Ensure that there is a positive connection between the tool holder (square drive of the nutrunner) and square drive of the impact socket wrench.

Conserving materials



In order to prevent premature damage to tools and accessories, only use the nutrunner up to 80% of the maximum torque of the nutrunner during continuous use, if possible to do so.

Especially during loosening, loads could occur that have adversely effect durability.

Torques in excess of 80% (based on the maximum torque of the nutrunner) should only be used in exceptional cases.

3.5.2 Noise and ergonomics

Noise



WARNING!

Danger of injury from noise!

The noise level of up to 95 dB(A) (3 dB(A) measurement uncertainty) occurring in the work area can cause hearing damage.

- Always wear hearing protection when working.
- Remain in the danger zone only for as long as your presence is required.

**Inadequate ergonomics****CAUTION!****Injuries to the musculoskeletal system due to the high weight of the nutrunner!**

Lifting and carrying heavy loads can cause permanent damage to the musculoskeletal system.

- Ensure stable footing and sufficient room for movement.
- Keep your back as straight as possible. Do not lift with your upper body hunched over, bent forward, or with your back arched.
- Lift the nutrunner as close to your body as possible.
- Avoid one-sided loading. Avoid twisting your spine. Do not carry one-handed.
- Never move the nutrunner abruptly.
- Use the safety swivel joint to rotate the trigger in such a way that it is possible to work without any discomfort.
- Use suitable auxiliary devices (e.g. lifting eyes).

Inattention**WARNING!****Danger of injury due to distraction, inattention or irresponsible use!**

Distraction, inattention or irresponsible use can result in losing control of the nutrunner and thus cause serious injuries.

- Always keep the work area well-lit.
- Keep children and unauthorised persons away.
- Work purposefully and in a responsible manner. Do not allow yourself to be distracted.
- Do not work if you are tired or under the influence of drugs, alcohol or medicine.
- Do not be lulled into a false sense of security. Do not disregard the safety information and instructions in this manual, even if the nutrunner seems familiar to you after frequent use.
- When the nutrunner is not in use, always store it in the transport case out of reach from children and other unauthorised persons.
- Wear the prescribed personal protective equipment.

Faulty safety devices



WARNING!

Danger of death from inoperative safety devices!

If safety devices or safety functions are inoperative or disabled, there is a danger of serious injuries.

- Prior to commencing work, check that all safety devices are operative and correctly installed.
- Never disable or bypass safety devices or safety functions.

The nutrunner is equipped with the following safety devices and safety functions:

- Safety swivel joint
The safety swivel joint prevents reaction forces acting on the wrist.
- Automatic release function
Load on the gearbox is relieved after the fastening operation. The nutrunner can be removed more easily.
- Insulated pistol grip
- Start-up protection/transport position
The nutrunner is protected against unintentional start-up in the middle position of the direction of rotation setting.
- Reaction arm circlip
The reaction arm is protected against outward ejection by means of a circlip.
- Spring clip for impact wrench socket
The impact wrench socket is secured against outward ejection by means of a spring clip on the square drive of the nutrunner.

Automatic release function

Load on the gearbox is relieved after the bolting process. The reaction arm retracts slightly. This makes it easier to remove the nutrunner from the bolt and facilitates further work.



3.6 Operator's obligations

The nutrunner is used in the commercial sector. The operator of the nutrunner is therefore subject to the statutory obligations pertaining to occupational safety.

In addition to the safety instructions in this manual, the applicable safety, occupational safety and environmental protection regulations for the nutrunner's area of application must be adhered to.

The following specifically applies in this regard:

- The operator must familiarise themselves with the applicable occupational safety regulations and, as part of a risk assessment, determine additional dangers that arise as a result of the specific operating conditions at the operating site of the nutrunner. The findings of this risk assessment must be used to draft safety instructions for operating the nutrunner.
- During the entire time the nutrunner is in use, the operator must check whether the safety instructions they have compiled reflect current regulations and, if necessary, the operator must change the instructions accordingly.
- The operator must clearly define and regulate responsibilities for all work on and with the nutrunner. The authority and responsibilities of personnel regarding operation, set-up, maintenance and repair must be clearly defined.
- The operator must reliably check the use of the nutrunner and ensure that only commissioned and instructed personnel work with the nutrunner. Only allow personnel to be trained or instructed and those undertaking vocational training to work on the nutrunner under the supervision of an experienced person.
- The operator must ensure that the nutrunner is not opened and that no work is performed by unauthorised persons.
- The work environment, method of use and specific conditions of the respective fastening operations may result in vibration and noise emissions to differ from those indicated.

Measure the actual noise emissions.

Estimate vibration loads occurring under the actual conditions of use. Take into account the relative impact of the various operating cycles.

The operator must ensure that the applicable safety, occupational safety and environmental regulations are observed and that their limits are not exceeded. In the event of additional loads or stresses, define and implement additional safety precautions.

The operator is also responsible for ensuring that the nutrunner is in technically flawless condition at all times. The following applies for this reason:

- The operator must ensure adherence to the maintenance intervals described in this manual.
- The operator must have the functionality and integrity of all safety devices checked on a regular basis.

3.7 Who is permitted to use the nutrunner?



WARNING!

Danger of injury if personnel are insufficiently qualified!

If unqualified personnel perform work on or with the nutrunner or if such persons are present in the danger zone while work is being performed, dangers arise that could cause serious injuries and considerable property damage.

- Have all tasks performed by suitable qualified personnel without exception.
- Keep unqualified personnel away from the danger zones and work areas.

User

The user of the nutrunner has the requisite knowledge and the requisite training for handling pneumatic tools. Furthermore, during training by the operator, users have been trained in relation to the tasks assigned to them and the potential dangers associated with improper conduct.

The user is trained in how to use the personal protective equipment, is familiar with the most important specifications, situations and information relating to the specific application and is physically capable of using the nutrunner safely despite its weight. This includes overhead work, working at heights, etc.

The user must be older than the legally permissible minimum age.

Users may only perform tasks that exceed operation under normal operating conditions if this is specified in this manual and the operator has expressly entrusted the users with the performance of such tasks.

The user knows who their supervisor is, can contact their supervisor if they have questions or in an emergency, and is able to communicate with their supervisor.

The user is familiar with all residual risks and is trained in the practical handling of the nutrunner.

Qualified nutrunner personnel

Qualified nutrunner personnel are trained for the specific task area in which they work and are familiar with the relevant standards and regulations.

Due to their professional training and experience, qualified nutrunner personnel are able to perform work with the nutrunner, recognise and avoid potential dangers independently and convey this to users.

Specific capabilities of qualified nutrunner personnel include:

- Identify the particulars of a fastening operation.
- Prepare the nutrunner.
- Select the appropriate impact wrench socket.
- Prepare the pneumatic system for operation with the nutrunner and set the pneumatic pressure.



- Uphold safety, occupational safety and health protection when using the nutrunner and convey this to users.
- Identify damage on the nutrunner and arrange for repairs or get in touch with the manufacturer.
- Instruct users in the proper manner.

Operator

The operator is the person who operates the nutrunner for commercial or economic purposes themselves, or makes it available for a third party to use, and who bears legal responsibility for the product vis-à-vis protection of personnel and third parties during operation.

🔗 *Chapter 3.6 'Operator's obligations' on page 29*

PLARAD[®] service

Certain work may only be performed by PLARAD[®] service or by personnel authorised by Maschinenfabrik Wagner GmbH & Co. KG. Other personnel are not authorised to perform this work. Contact PLARAD[®] service or authorised PLARAD[®] partners regarding performance of the work that is due.

Contact: www.plarad.de

🔗 *Chapter 10.6 'Having service tasks performed by the manufacturer' on page 52*

Unauthorised persons



WARNING!

Danger of death for unauthorised persons due to dangers in the danger zone and work area!

Unauthorised persons, who do not meet the requirements described in this manual, are not aware of the dangers in the danger zone. There is therefore a danger of serious injuries or even death for unauthorised persons.

- Keep unauthorised persons away from the danger zone and work area.
- If in doubt, address the respective persons and instruct them to leave the danger zone and work area.
- Suspend work while there are unauthorised persons loitering in the work and danger zone.

3.8 Personal protective equipment

Safety gloves



Safety gloves are used to protect the hands from friction, abrasions, punctures or deeper injuries and from contact with hot surfaces.

Safety shoes



Safety shoes protect the feet from crushing, falling parts and from slipping on slippery ground.

Hearing protection



Hearing protection is used to protect against hearing damage cause by noise.

Safety goggles



Safety goggles are used to protect the eyes from airborne parts and liquid jets.

Protective work clothing



Protective work clothing is tight fitting work clothing with a low tearing resistance, with tight sleeves and without any protruding parts.

Protective cap



The protective cap (hairnet) is used to protect the hair from being pulled in by rotating and moving parts, such as bolts.

The wearing of a protective cap is mandatory if your hair is longer than the circumference of the moving shaft.

Industrial safety helmet



Industrial safety helmets are used to protect the head from falling objects, suspended and swinging objects and from bumping into stationary objects.

An industrial safety helmet must be worn for overhead work involving the nutrunner.



3.9 Environmental protection



ENVIRONMENT!

Danger of pollution from incorrect handling of environmentally hazardous substances!

If environmentally hazardous substances are handled incorrectly, especially if such substances are disposed of incorrectly, this could cause significant damage to the environment.

- Always adhere to the instructions given below in relation to the handling of environmentally hazardous substances and the disposal thereof.
- If environmentally hazardous substances accidentally enter the environment, adopt suitable measures immediately. If in doubt, notify the competent local authority of the damage and inquire about suitable measures to be taken.

The following environmentally hazardous substances are used:

Lubricants

Lubricants, such as greases and oils, contain toxic substances. Such substances must not enter the environment.

Arrange for such substances to be disposed of by a specialist disposal company.

Cleaning agents

Cleaning agents may contain toxic substances. Such substances must not enter the environment.

Arrange for cleaning agents, and cloths soiled by cleaning agents etc., to be disposed of by a specialist disposal company.

4 Determining the bolting process

Information about bolted connections

The nutrunner reacts differently to “soft” and “hard” bolted connections. Even “soft” and “hard” bolted connections react individually to each other, as the thread and lubrication state can vary from bolted connection to bolted connection.

The torque setting of the nutrunner must be made for each bolting process individually and checked directly during the bolting process.

Use a rotating, electrical measuring transducer or a calibrated torque spanner for checking purposes.

Personnel: ■ Operator

The nutrunner can only be used safely and properly if the bolting process is known.



Fig. 10: Mobile measuring unit TC1

1. Determine the bolting process. To do so:

Determine a suitable bracing surface and select a suitable reaction arm for proper bracing.

Determine the appropriate impact wrench socket.

2. Determine the requisite torques and angles for the bolting process.

To this end, measure the applied torque of a bolting process, e.g. using the mobile measuring unit TC1 (not included in the scope of delivery; see available accessories).

3. Make further accessories (bracing aids, suspension etc.) available according to the situation.



5 Preparing the nutrunner

Unsecured or overloaded components



WARNING!

Danger of injury due to unsecured or overloaded components!

Unsecured components or components subjected to loads exceeding the intended use could result in uncontrolled nutrunner behaviour, outward ejection of components or breakage and thereby cause serious injuries.

- Carefully determine all parameters for a bolting process.
- Ensure that all components are used within the scope of their intended use.
Never exceed load limits (e.g. maximum torques).
- Only use impact wrench sockets.
- Never put the nutrunner into operation if the reaction arm or impact wrench socket are unsecured.

- Personnel: ■ Qualified nutrunner personnel
- Protective equipment: ■ Protective work clothing
 ■ Safety shoes

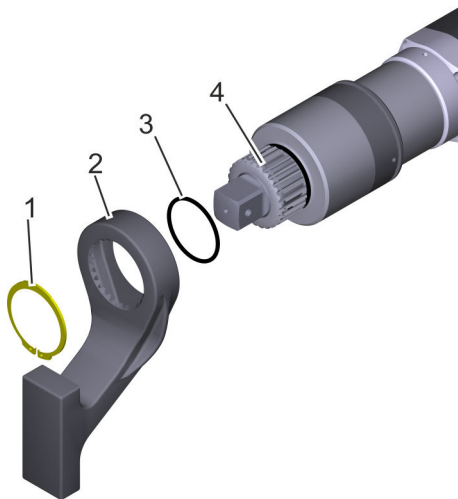

Fig. 11: Securing the reaction arm

- 1 Circlip
- 2 Reaction arm
- 3 O-ring
- 4 Serration

Prior to being used for tightening or loosening, the bolting process must be known and the nutrunner must be prepared.

1. → Ensure that the bolting process has been determined & Chapter 4 'Determining the bolting process' on page 34 and that all parameters are available.

2. →



NOTICE!

Property damage to the O-ring!

Carefully slide the O-ring (Fig. 11/3) onto the serration (Fig. 11/4) on the nutrunner.

3. → Push the reaction arm (Fig. 11/2) onto the serration.



Fig. 12: Circlip pliers

- 4.** → Slide on the circlip (Fig. 11/1) with the aid of the circlip pliers (Fig. 12) and clamp it.

⇒ The reaction arm is secured.

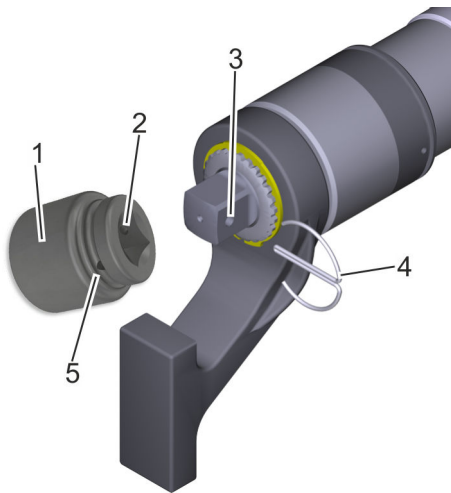

Fig. 13: Securing the impact wrench socket

- 1 Impact wrench socket
- 2 Bore
- 3 Square drive with bore
- 4 Spring clip for impact wrench socket
- 5 Bore

- 5.** → Attach the impact wrench socket (nut) to the square drive on the nutrunner and secure it.

To do so, push the impact wrench socket (Fig. 13/1) fully onto the square drive (Fig. 13/3). The bores (Fig. 13/2, 3 and 5) for securing must be on top of each other.

Fully insert the spring clip (Fig. 13/4) in all bores (Fig. 13/2, 3 and 5) until the ring is fully seated.

⇒ The impact wrench socket is secured.

- 6.** → Attach further accessories if such accessories have been determined for the bolting process.



6 Supplying with energy

6.1 Supplying pneumatic energy

Air compressor system

Operation of the pneumatic nutrunner requires an air compressor system provided by the operator with a service unit for compressed air. The service unit for compressed air must have the following minimum equipment:

- Water separator (filter)
- Pressure regulator
- Oil mist lubricator



Air compressor system requirements ↗ Chapter 2.5 'Service unit for compressed air (provided by the operator)' on page 12.

➔ Ensure that the air compressor system provided by the operator and the service unit for compressed air in use satisfy the requirements.

Note the operating instructions for the service unit for compressed air provided by the operator.

6.2 Checking the filter

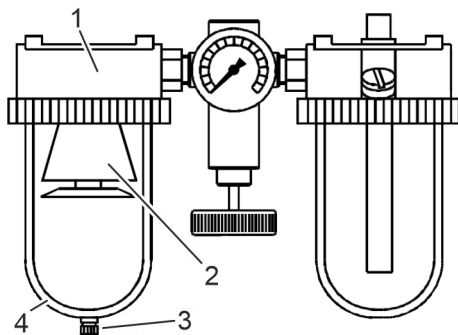

Fig. 14: Water separator (filter)

- 1 Water separator
- 2 Filter
- 3 Condensate drain
- 4 Condensate tank

Personnel: ■ User

The filter must function properly to ensure faultless operation of the nutrunner.

1. ➔ Drain the condensate at the water separator (Fig. 14/1).
2. ➔ Check the filter (Fig. 14/2) for dirt. Clean the filter if it is dirty
↗ Chapter 10.4 'Cleaning the filter' on page 50.

6.3 Connecting the nutrunner to the compressed air

Personnel: ■ User

Prerequisite:

The compressed air supply meets the requirements [Chapter 6.1 'Supplying pneumatic energy'](#) on page 37.

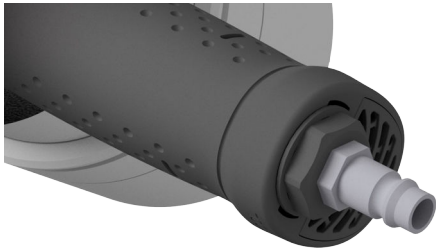

Fig. 15: Compressed air port

1. ➤ Clean the compressed air port (Fig. 15).
2. ➤ Use only an undamaged air compressor hose. Ensure that the air compressor hose is routed properly. Avoid routing it over sharp edges, squashed, in small radii, in loops, etc.
3. ➤ Push the quick-release coupling of the air compressor hose all the way onto the compressed air port of the nutrunner.
 - ⇒ The quick-release lock engages.

6.4 Setting the oil mist lubricator

Personnel: ■ User

The oil requirements are system-dependent. Guide values:

- Up to 2 bar operating pressure – 1 drop per minute
- Above 2 bar operating pressure – 2 drops per minute

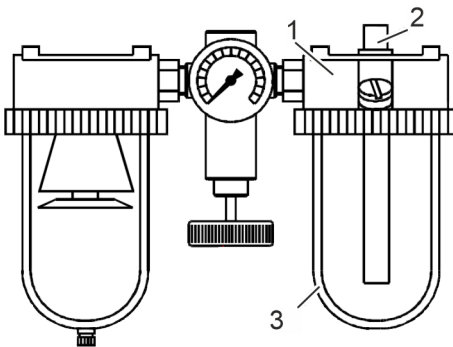

Fig. 16: Setting the oil mist lubricator

- 1 Oil mist lubricator
- 2 Dosing screw
- 3 Oil tank

1. ➤ Check the oil level on the oil mist lubricator (Fig. 16/1). If the level is low, top up the oil [Chapter 10.5 'Filling the oil mist lubricator'](#) on page 51.
2. ➤ Set the oil quantity (drops per minute) during operation at the dosing screw (Fig. 16/2). The number of drops is visible in the sight glass.
 - ↺ Increase oil quantity – Turn the dosing screw anti-clockwise
 - ↻ Reduce oil quantity – Turn the dosing screw clockwise

6.5 Setting the torque

Personnel: ■ User

The pressure regulator is used to set the torque of the nutrunner. Note the torque chart in this regard.

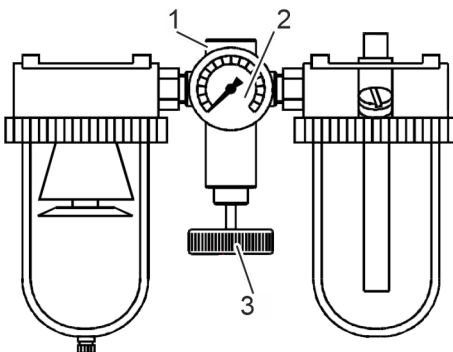



Fig. 17: Setting the torque

→  *The operating pressure to be set is the flow pressure of the air compressor system provided by the operator.*

Set the operating pressure. To do so, press and hold the trigger and, at the same time, use the pressure setting (Fig. 17/3) to regulate the pressure.



- 1 Pressure regulator
- 2 Pressure display
- 3 Pressure adjustment

7 Bracing the reaction arm

Reaction arm

Torques can only be generated if the reaction forces are absorbed. The reaction arm fulfils this function on the nutrunner:

The scope of delivery for the nutrunner contains a standard reaction arm. The nutrunner may only be used with the reaction arm included in the delivery.

For bolting processes for which the standard reaction arm is unsuitable, contact PLARAD[®] service.

Incorrect bracing and overloading



WARNING!

Danger of injury due to incorrect bracing, overloading, breakage!

If the nutrunner is not sufficiently braced, it can slip out of place and be ejected. Any point contact between the reaction arm and the corners of a bracing element can cause considerable forces to act on the nutrunner. Incorrect bracing or overloading of the reaction arm, bolts or other components can result in serious injuries and damage to the nutrunner.

- Do not use the nutrunner if the bolting process is not entirely clear.
- Note the torque chart.
- Check the reaction arm for visible damage prior to use. Do not use the reaction arm if it is damaged.
- Brace the reaction arm correctly. Note the following instructions regarding bracing.
- Always ensure that the reaction arm is in full contact with the surface.
- Use only PLARAD[®] original reaction arms.



Bracing



Fig. 18: Bracing the reaction arm correctly

- 1 Reaction arm
- 2 Starting rotation angle

- 3 Bracing/abutment
→ Correct bracing point

1. Find the ideal bracing surface for the fastening operation. Ensure that the reaction arm (Fig. 18/1) is in full contact with the bracing surface (Fig. 18/3) and cannot slip out of place. Note the starting angle of rotation (Fig. 18/2).

If the standard reaction arm is not suitable for this, use a suitable reaction arm. If you have questions, contact PLARAD[®] service.



Fig. 19: Reaction arm braced incorrectly

→ Incorrect bracing point

2. Ensure that only the points (Fig. 18) marked with → absorb the torque and are in full contact.

8 Tightening

Danger of crushing



WARNING!

Danger of crushing between the reaction arm and bracing surface!

Body parts could get between the reaction arm and bracing surface. This could result in serious injuries.

- Never put body parts between the reaction arm and bracing surface.
- Carefully attach the impact wrench socket.

Overloading and breakage



WARNING!

Danger of injury due to overloading and breakage!

Overloading of the nutrunner or individual components can result in serious injuries.

- Do not use the nutrunner if the fastening operation is not entirely clear.
- Note the torque chart.
- Check the reaction arm for visible damage prior to use. Do not use the reaction arm if it is damaged.
- Brace the reaction arm correctly ↪ *Chapter 7 'Bracing the reaction arm' on page 40.*

Starting the fastening operation



Contact PLARAD[®] service prior to operation at temperatures below 0°C.

1. ➤ Ensure that the nutrunner has been properly prepared (↪ *Chapter 5 'Preparing the nutrunner' on page 35*) and that the fastening operation is known (↪ *Chapter 4 'Determining the bolting process' on page 34.*)
2. ➤ Ensure that the nutrunner is being supplied with compressed air (↪ *Chapter 6 'Supplying with energy' on page 37.*)
3. ➤ Ensure that the right torque for the fastening operation is set as per the torque chart. Use the pressure regulator to do so (↪ *Chapter 6.5 'Setting the torque' on page 38.*)
4. ➤ Attach the nutrunner to the bolted connection in such a way that the full height of the bolt head or nut is gripped by the impact wrench socket.

If this is not possible, use an impact wrench socket and accessories that match the fastening operation.

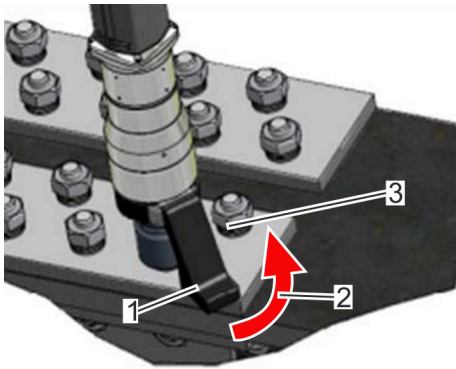

Fig. 20: Starting rotation angle

- 1 Reaction arm
- 2 Starting rotation angle
- 3 Bracing

5. → Ensure that the reaction arm (Fig. 20/1) is braced against a bracing surface (Fig. 20/3) on its side facing the nutrunner's desired direction of rotation. Ensure that there is full contact.



NOTICE!

On pre-tightened bolted connections, torque mode will always exceed the set torque if the starting rotation angle between reaction arm (Fig. 20/1) and bracing position (Fig. 20/3) is too small.

Note the starting rotation angle (Fig. 20/2) as per the chart.



DP2power	Recommended starting rotation angle
DP2power-05	30°
DP2power-10	30°
DP2power-20	15°
DP2power-30	15°
DP2power-36	15°
DP2power-48	15°
DP2power-80	15°

Direction of rotation



Fig. 21: Direction of rotation setting

6. →

		Direction of rotation setting	Direction of rotation
	1	Right-hand side is pressed.	Clockwise (CW) Tightening in clockwise direction
		Middle position	No rotation possible. Transport position
	2	Left-hand side is pressed.	Anti-clockwise (CCW) Loosening in anti-clockwise direction

To tighten in clockwise direction (CW), push the direction of rotation setting (Fig. 21/1) to the right.

Trigger



Fig. 22: Trigger

Checking the result

7. ➔



NOTICE!
Damage due to pulsing!

Press and hold the trigger (Fig. 22/1) until the fastening operation has concluded and the bolt is no longer turning. Do not pulse (press and release the trigger in quick succession).

8. ➔

Do not retighten. Do not repeat correctly completed fastening operations.

9. ➔

Check the torque with a suitable torque gauge to verify that the fastening operation was successful.



9 Loosening

Danger of crushing



WARNING!

Danger of crushing between the reaction arm and bracing surface!

Body parts could get between the reaction arm and bracing surface and result in serious injuries.

- Never put body parts between the reaction arm and bracing surface.
- Carefully attach the impact wrench socket.

Overloading



NOTICE!

Damage due to overloading!

Significant torques are exerted on the components during loosening. This can cause breakages.

- Do not overload components.

Starting the loosening process



Contact PLARAD[®] service prior to operation at temperatures below 0°C.



1. ➤ Ensure that the nutrunner has been properly prepared (↪ Chapter 5 'Preparing the nutrunner' on page 35) and that the fastening operation is known ↪ Chapter 4 'Determining the bolting process' on page 34.
2. ➤ Ensure that the nutrunner is being supplied with compressed air ↪ Chapter 6 'Supplying with energy' on page 37.
3. ➤ Ensure that the right torque for the fastening operation is set as per the torque chart. Use the pressure regulator to do so ↪ Chapter 6.5 'Setting the torque' on page 38.
4. ➤ Attach the nutrunner to the bolted connection in such a way that the full height of the bolt head or nut is gripped by the impact wrench socket.

If this is not possible, use an impact wrench socket and accessories that match the fastening operation.
5. ➤ Ensure that the reaction arm is braced against a bracing surface on its side facing the nutrunner's desired direction of rotation. Ensure that there is full contact.

Direction of rotation



Fig. 23: Direction of rotation setting

6. ▶		Direction of rotation setting	Direction of rotation
	1	Right-hand side is pressed.	Clockwise (CW) Tightening in clockwise direction
		Middle position	No rotation possible. Transport position
	2	Left-hand side is pressed.	Anti-clockwise (CCW) Loosening in anti-clockwise direction

To loosen in anti-clockwise direction (CCW), push the direction of rotation setting (Fig. 23/2) to the left.

Trigger



Fig. 24: Trigger

7. ▶

! NOTICE!
Damage due to overloading!

In order to loosen bolted connections, it is often the case that greater torques are needed than those required for bolting. Ensure that all components are designed for this load.

8. ▶ Press and hold the trigger (Fig. 24/1) until the loosening process has been completed. Do not pulse (press and release the trigger in quick succession).



10 Performing maintenance

10.1 Maintenance schedule

Improperly performed maintenance tasks



WARNING!

Danger of injury from improperly performed maintenance tasks!

Improper maintenance can cause serious injuries and significant property damage.

- Ensure sufficient assembly space prior to commencing the tasks.
- Ensure that the assembly site is clean and tidy. Loosely stacked or randomly scattered components and tools may cause accidents.
- With regard to maintenance tasks, only allow “Clean nutrunner” and “Have it checked for damage” to be performed by the user.
- Have all repairs performed by the manufacturer.
- Never open the nutrunner.
- Use only PLARAD[®] original parts.

Faultless operation

The following sections describe the maintenance tasks that are required in order to ensure optimum and faultless operation.

If routine checks reveal increased wear, shorten the requisite maintenance intervals according to the actual signs of wear. If you have questions about maintenance tasks and intervals, contact PLARAD[®] service.

Interval	Maintenance task	Personnel
Before and after every use	<ul style="list-style-type: none"> ■ Clean. ■ Check surfaces, warning symbols and pictograms for damage. ■ Check the compressed air port for damage. ■ Service the service unit for compressed air as per the manufacturer's specifications. <ul style="list-style-type: none"> ↳ Chapter 10.3 'Draining condensate' on page 50 ↳ Chapter 10.4 'Cleaning the filter' on page 50 ↳ Chapter 10.5 'Filling the oil mist lubricator' on page 51 ■ Check the impact wrench socket and spring clip for damage and correct operation. ■ Check the reaction arm and circlip for damage and correct operation. <p>↳ Chapter 10.2 'Maintenance by the user' on page 49</p>	User
<p>Every 3 months</p> <ul style="list-style-type: none"> ■ In the event of extreme operating conditions (e.g. dust, dirt) ■ In the event of high frequency of use, multi-shift operation ■ In the event of constant work in the upper torque range ■ In the event of soft fastening operations 	<ul style="list-style-type: none"> ■ Drive motor Perform service as stipulated by the motor manufacturer. ■ Planetary gearbox Perform service as stipulated by the manufacturer. Lubricate. ■ Nutrunner Exchange damaged markings. Recalibrate. Determine characteristics. Create torque chart/factory certificate. ■ Accessories Check for damage; exchange. ■ Exchange damaged markings. <p>↳ Chapter 10.6 'Having service tasks performed by the manufacturer' on page 52</p>	PLARAD [®] service
<p>Every 6 months</p> <ul style="list-style-type: none"> ■ In the event of standard operating conditions ■ In the event of average frequency of use ■ In the event of work in the medium torque range 		
<p>Every 12 months</p> <ul style="list-style-type: none"> ■ In the event of low frequency of use ■ In the event of work in the low torque range 		

Accessories, spare parts and wear parts

Spare parts must meet the technical requirements specified by PLARAD[®]. This is always ensured by original spare parts. A warranty can only be provided for original spare parts supplied by PLARAD[®].



The installation or use of other spare parts can, under certain circumstances, adversely alter the specified design properties and, consequently, impair active or passive safety.

Any liability and warranty for damage resulting from the use of parts other than the original spare parts and accessory parts is excluded.

Have at least the following information about the nutrunner to hand to enable quick and easy processing:

- Client
- Serial number of the nutrunner
- Desired spare part
- Desired quantity
- Desired mode of shipping

🔗 *'PLARAD[®] service' on page 4*

10.2 Maintenance by the user

Personnel: ■ User

Perform the following maintenance steps before and after every use:

Cleaning

1. ➔



NOTICE!
Damage from improper cleaning!

Clean the nutrunner with a soft cloth. Never use strong cleaning agents, water, brushes, sharp-edged tools or high-pressure cleaners.

Surfaces and markings

2. ➔

Check surfaces and markings for damage. Arrange for repairs if there is damage or illegible markings.

Plastic tank of the service unit for compressed air

3. ➔



NOTICE!
Damage due to inappropriate cleaning agents!

Clean the plastic tank of the service unit for compressed air. Use only water, petroleum or petroleum ether to do so. Never use cleaning agents containing petrol, benzene, acetone or trichloroethylene.

Impact wrench socket

4. ➔

Check the impact wrench socket and spring clip for damage, deformation and correct operation. Arrange for exchange if there is damage.

Reaction arm

5. ➔

Check the reaction arm for damage and deformation. Check the circlip for correct operation. Arrange for exchange if there is damage.

Water separator

6. ➔

Drain the condensate 🔗 *Chapter 10.3 'Draining condensate' on page 50.*

Filter

Oil mist lubricator

Air compressor hose and compressed air port

7. ➤ Clean the filter ↗ *Chapter 10.4 'Cleaning the filter' on page 50.*

8. ➤ Fill the oil mist lubricator ↗ *Chapter 10.5 'Filling the oil mist lubricator' on page 51.*

9. ➤ Clean the quick-release couplings.

Check the air compressor hose and compressed air port for damage and correct operation. Arrange for exchange if there is damage.

10. ➤



WARNING!

Danger of injury due to faulty nutrunner!

Do not use a faulty nutrunner. This also applies if there are leaks. Have it repaired immediately or have the faulty parts exchanged. Contact PLARAD[®] service.

11. ➤ Store the cleaned and damage-free nutrunner in the transport case until its next use.

Transport case

10.3 Draining condensate

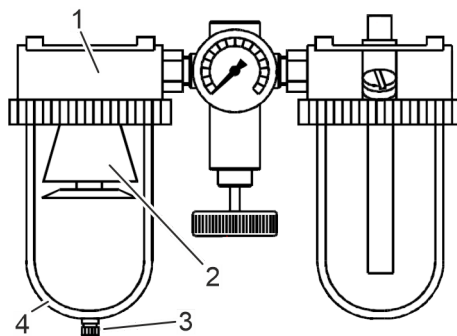

Fig. 25: Water separator

- 1 Water separator
- 2 Filter
- 3 Condensate drain
- 4 Condensate tank

Personnel: ■ User

The compressed air provided by the operator is cleaned in the service unit for compressed air. Condensate builds up in the condensate tank in the process.

The condensate must be emptied no later than when it is full. Note the marking for the maximum permissible level.

1. ➤ Open the condensate drain (Fig. 25/3) and collect the condensate.

2. ➤ Close the condensate drain (Fig. 25/3).

3. ➤ Unscrew the condensate tank (Fig. 25/4) if it is dirty.

4. ➤ Clean the condensate tank (Fig. 25/4) in the proper manner. Note the cleaning guidelines in the operating instructions for the service unit for compressed air.

5. ➤ Screw on the condensate tank (Fig. 25/4).

Ensure that the condensate drain (Fig. 25/3) is closed.

10.4 Cleaning the filter

Personnel: ■ User

If it is dirty, clean the filter (Fig. 25/2) as follows:

1. ➤ Unscrew the condensate tank (Fig. 25/4).

2. ➤ Loosen the filter fastener.



3. ➤ Take out the filter.
4. ➤ Use suitable cleaning agents to clean the filter. Dry the filter. Note the operating instructions for the service unit for compressed air.
5. ➤ Put the filter (Fig. 25/2) back in. In doing so, ensure a flawless seal.
6. ➤ Screw on the condensate tank (Fig. 25/4).
7. ➤ Dispose of the solvent and/or washing solution in an environmentally sound manner.

10.5 Filling the oil mist lubricator

Personnel: ■ User

The oil mist lubricator ensures reliable lubrication of the nutrunner's drive motor.

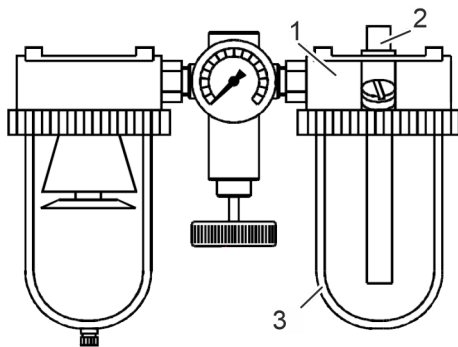

Fig. 26: Oil mist lubricator

- 1 Oil mist lubricator
- 2 Dosing screw for setting the oil quantity
- 3 Oil tank

1. ➤



It can be refilled during operation without shutting down the compressed air.

Open the oil fill opening.

2. ➤ Fill the oil tank (Fig. 26/3) with oil. Note the operating instructions for the service unit for compressed air.

↳ 'Oil specifications' on page 51

3. ➤ Seal the oil fill opening.

4. ➤ Collect any spilled oil in the proper manner. Clean the work environment.

Dispose of cleaning agents and any oil collected in an environmentally sound manner.

Oil specifications

Recommended oils:

- SHELL Cassida Fluid HF 32
- VIA Avilup RSL 46
- BP Energol HPL 46
- ESSO Nuto H
- TEXACO Rando Oil HD C 38

10.6 Having service tasks performed by the manufacturer

Service intervals

The service intervals are dependent on the conditions of use and the operating site.

Service interval	Conditions
Every 3 months	<ul style="list-style-type: none"> ■ In the event of extreme operating conditions (e.g. dust, dirt) ■ In the event of high frequency of use, multi-shift operation ■ In the event of constant work in the upper torque range ■ In the event of soft fastening operations
Every 6 months	<ul style="list-style-type: none"> ■ In the event of standard operating conditions ■ In the event of average frequency of use ■ In the event of work in the medium torque range
Every 12 months	<ul style="list-style-type: none"> ■ In the event of low frequency of use ■ In the event of work in the low torque range

Contacting service



WARNING!

Danger of injury and property damage due to improperly performed service tasks!

Improperly performed service tasks can cause incorrect bolted connections, destruction of the nutrunner and to injuries.

- Do not perform service tasks yourself.

→ Contact PLARAD[®] service in good time regarding the following service tasks.

Service tasks

Personnel: ■ PLARAD[®] service

Component	Service task
Drive motor	Perform service in accordance with the manufacturer's specifications.
Planetary gearbox	Perform service as stipulated by the manufacturer.
	Lubricate.
Accessories	Check for damage; exchange.
	Exchange damaged markings.
Nutrunner	Exchange damaged markings.
	Recalibrate. Determine characteristics.
	Create torque chart/factory certificate.



Torque chart



The torques need to be checked after repairs and, in the event of deviations, a new torque chart or a new torque selection diagram needs to be created.

11 Troubleshooting

11.1 Identifying faults

Malfunctions and faults can become noticeable in different ways:

- Nutrunner is not working for no apparent reason:
First note the list of typical errors and issues ↪ *'FAQs'* on page 54.
- Nutrunner or accessory is faulty or shows signs of damage.
Contact ↪ *'PLARAD® service'* on page 4.

FAQs

Below is a summary of typical malfunctions, issues and answers. This is intended to provide rapid assistance. For problems that cannot be solved in this way, contact ↪ *'PLARAD® service'* on page 4.

Fault symptom	Measure
The nutrunner will not start.	Check the pressure setting.
Compressed air escaping	Clean the quick-release couplings.
	Check the air compressor hose and compressed air ports for damage. Replace the air compressor hose if it is damaged. Have the compressed air ports replaced. Contact ↪ <i>'PLARAD® service'</i> on page 4.
	Have the nutrunner checked for damage. Contact ↪ <i>'PLARAD® service'</i> on page 4.
Insufficient flow rate (pressure fluctuations)	No compressed air lubrication. Fill the oil mist lubricator ↪ <i>Chapter 10.5 'Filling the oil mist lubricator'</i> on page 51.
	Clean the filter ↪ <i>Chapter 10.4 'Cleaning the filter'</i> on page 50.



11.2 Performing troubleshooting

Improperly performed troubleshooting



WARNING!

Danger of injury from improperly performed troubleshooting!

Improper troubleshooting can cause serious injuries and significant damage.

- Ensure that the user only cleans the nutrunner and checks for damage.
- Have all repairs performed by the manufacturer.
- Never open the nutrunner.
- Use only PLARAD[®] original parts.

Device damage

- Contact ☎ *'PLARAD[®] service'* on page 4 if there is any damage to the nutrunner.

Returning to service after repair



WARNING!

Danger of injury due to faulty nutrunner!

If a nutrunner is not properly repaired, this can cause serious injuries.



- Never put a defective nutrunner back into service.

- Check for correct operation prior to first-time use.

12 Disposing of the nutrunner

The nutrunner must be disposed of in an environmentally sound manner at the end of its service life.

Disassembly

1.  Disconnect the nutrunner from the compressed air supply.
2.  Remove the impact wrench socket, reaction arm, and all other optional attachment parts.
3.  Do not dismantle the nutrunner any further.

Disposal

Insofar as no take-back or disposal agreement has been put in place, dispose of the nutrunner in accordance with local regulations. Use authorised collection points for reprocessing.



ENVIRONMENT!

Danger to the environment due to incorrect disposal!

Incorrect disposal can be hazardous to the environment.

Dispose of the plastic transport case and foam inlay separately from the nutrunner.

If in doubt, obtain information about environmentally sound disposal from the local municipal authority or from specialist disposal companies.



13 Technical data

Technical data sheet



Technical data sheet is available online at:
<https://www.plarad.de/download-center.html>

Dimensions and weight

Dimensions and weight depend on the DP2power version. See the technical data sheet for specific values for the nutrunner.

Performance values

Data	Value
Performance range	See torque chart

DP2power	Torque range (Nm)	Idle speed at 4 bar (rpm)
DP2power-05	125 – 500	26.7
DP2power-10	250 – 1,000	11.9
DP2power-20	500 – 2,000	5.4
DP2power-30	600 – 3,000	3.4
DP2power-36	750 – 3,600	3.1
DP2power-48	1,200 – 4,800	2.2
DP2power-80	2,200 – 8,000	1.1



Idle speed

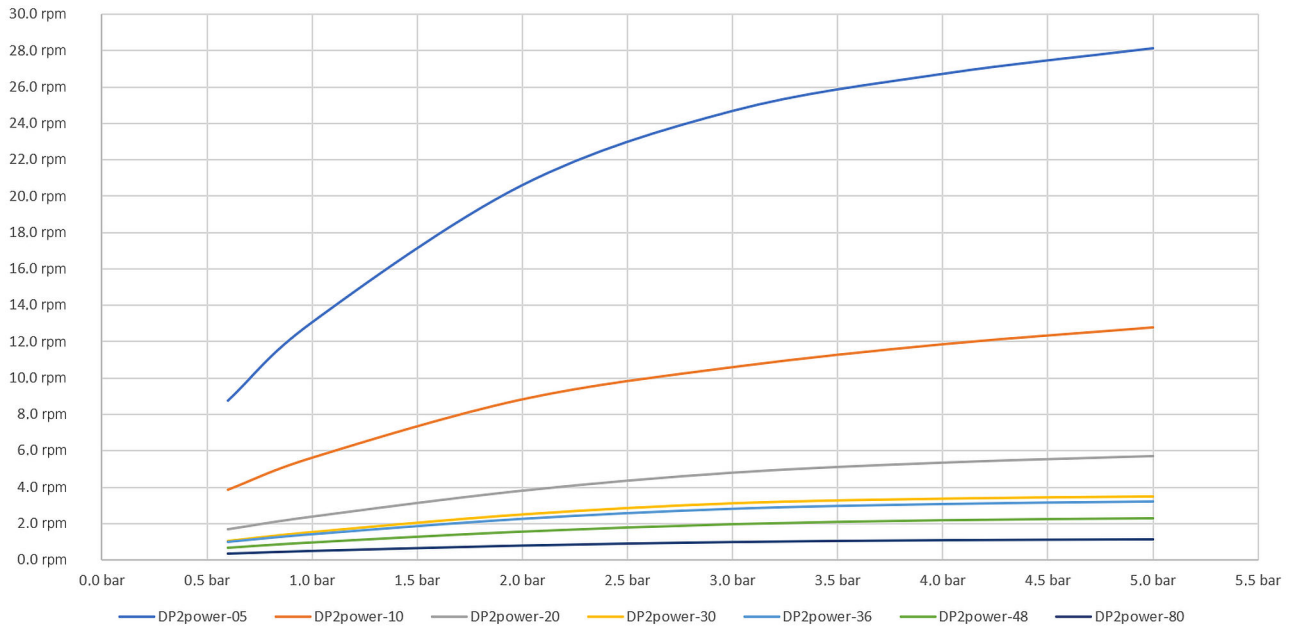

Fig. 27: Idle speed

Idle air volume

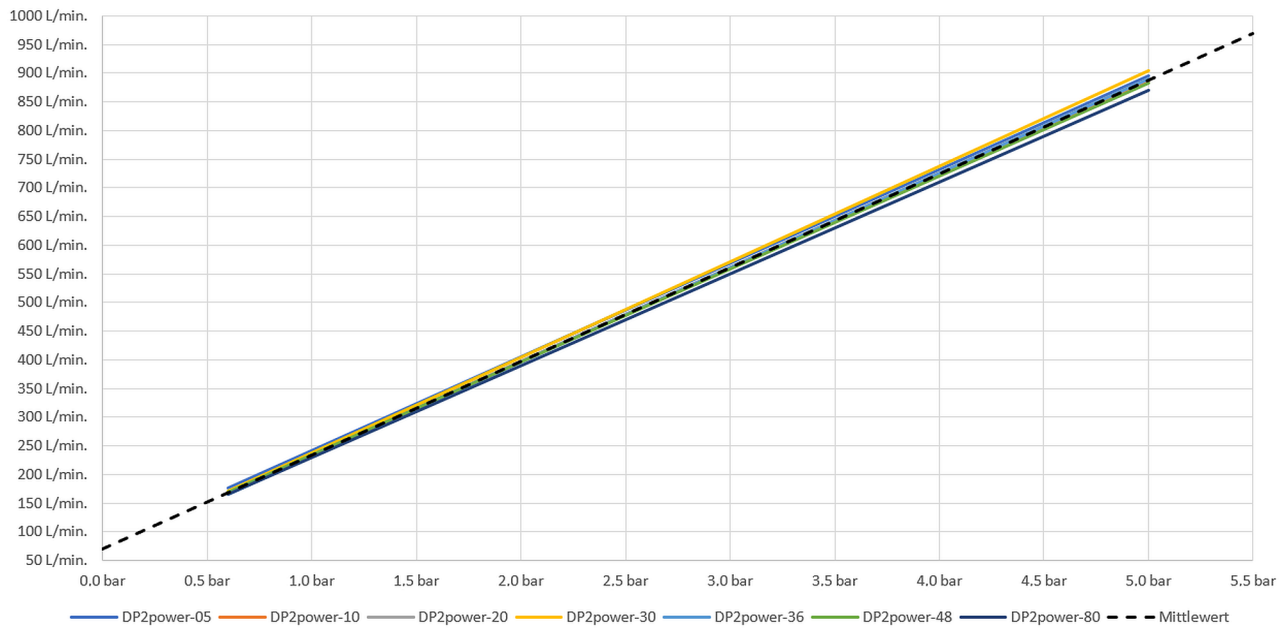

Fig. 28: Idle air volume



Pneumatic connected loads

Requirements for the pneumatic system provided by the operator:

Data	Value	Unit
Line pressure, constant	6	bar
Capacity of the air compressor system, minimum	1,000	l/min
Length of the air compressor hose*, maximum	3	m
Clear width of the air compressor hose, minimum	13	mm
Particle separation of the air filter	5	µm
Operating pressure of the oil mist lubricator, minimum	Depends on the manufacturer	

* Between service unit for compressed air and nutrunner

Environment

Data	Value	Unit
Temperature range	0 to 50	°C

Emissions

Emission levels as per EN 60745

Data	Value	Unit
Emission sound power level L_{WA}	*	dB(A)
Emission sound pressure level L_{pA}	*	dB(A)
Measurement uncertainty of emitted sound pressure level	3	dB(A)
Vibration total value	< 2.5	m/s ²
Measurement uncertainty for vibration total value	1.5	m/s ²

* See technical data sheet

14 Index

A		F	
Accessories	13	FAQ	54
Air compressor hose	13	Faults	54
Air compressor system	12	Identifying	54
Air filter	13	Rectifying	55
Angular gearbox	10	Filter	13
Authorised partners	4	Checking	37
Automatic release function	28	Cleaning	50
B		Foam inlay	7
Bracing the reaction arm	40	Functions	
Brief description	10	Loosening	45
C		Tightening	42
Case	7	G	
Cleaning	49	Getting to know	9
Condensate	13	H	
Connected loads	59	Handle	12
Controls	11	Help	31
Copyright	4	Hydraulic oil	51
Customer service	4, 31	I	
D		Illustration	9
Delivery	7	Impact wrench sockets	26
Checking	7	Inlay	7
Packaging material	8	Intended use	23
Scope	7	L	
Determining the bolting process	34	Loosening	45
Direction of rotation setting	11	Lubrication	13
Disassembly	56	M	
Disposal	56	Maintenance	47
Draining condensate	50	Cleaning	49
E		Manufacturer	52
Emissions	59	Overview	47
Environmental protection	33	User	49
Cleaning agents	33	Maintenance schedule	47
Lubricants	33	Manufacturer	4
Error	54	Maschinenfabrik Wagner	4
		Misuse	23



N	
Noise emissions	59
Nutrunner	
Maintaining	47
Preparing	35
Troubleshooting	54
O	
Offset head	
Bracing	15
Brief description	14
Cleaning	17
Conversion formulas for rotation angle	15
Grease nipple	17
Illustrations	14
Lubricating	17
Maintaining	16
Maintenance tasks	16
Preparing	15
Rating plate	15
Technical data	15
Using	15
Versions	14
Offset heads	14
Oil mist lubricator	13
Oil specifications	51
Oiler	13
Old devices	56
Operating	42
Operating conditions	59
Operation	42
Operator	31
Operator's obligations	29
Ordering spare parts	48
Other applicable documents	3
P	
Packaging material	8
Performance values	57
Personal protective equipment	31
Personnel	30
Personnel qualifications	30
Pistol grip	12
PLARAD customer service	31
PLARAD service	31
Pneumatics	12
PPE	31
Preparation	35
Q	
Qualified nutrunner personnel	30
R	
Rating plate	11
Release function	28
Residual risks	24
Bracing	24, 25
Breakage	24
Crushing	25
Ejecting	24
Moving components	24
Noise	26
Overloading	24
Rotational movements	24
Spare parts	24
Weight	25
S	
Safety	19
Safety devices	28
Service	4, 31
Service tasks	52
Service unit	12
Service unit for compressed air	12
Signs	21
Stickers	21
Suggestion for improvement	4
Symbols	
In this manual	19
On the nutrunner	21
T	
Technical data	57

Tightening	42	User	30
Transport position	11	User requirements	30
Trigger	12	W	
U		Water separator	13
Unauthorised persons	31	Who can I ask?	31
Unpacking	7		



Appendix

The following documents are supplied with the nutrunner in a document folder in addition to this manual.

- EU declaration of conformity
- Torque chart
- Certificates (option)